

Sanitary Pulsation Dampener

Per the attached, there have been some changes and clarifications in the instruction sheet supplied with the pulsation dampener.

The maximum allowable "system" operating pressure is 300 psi. This requirement is established by the tendency of the bladder to peel off the adapter plate, when the system pressure is more than three times the pre-charge gas pressure.

Also, we have determined the cause of the bladder failure to be inadequate air pressure. If the air pressure is not maintained, the bladder tends to fold over in the air inlet hole. The bladder then develops a circular cut on the inside about one inch from the opening. The inside lip of the air inlet hole can be smoothed to remove any sharp edges. We suggest that you:

1. Check your air pressure daily;
2. Check for leaks with a soap and water solution;
3. Do not use a constant-pressure-regulated airline that is permanently connected.

If your problems persist or you have any questions, please contact us.

***See attachment for Installation & Operation Instructions**



Assembly

1. Carefully unpack and examine your shipment. Any damage claims should be filed with the carrier immediately.
2. Remove the nuts and bolts on the four-inch clamp assembly (3). Remove the four-inch clamp gasket (2), the adapter plate (1) and the dampener screen (5).
3. Examine Figure 1. Assemble the bladder (8) onto the boss of the adapter plate (1). Note that this is a tight fit. The best assembly procedure is to fold back the "beaded" open end of the bladder and hold the bladder against the boss of the adapter plate. Then unfold the bladder bead over the boss, making sure that the bladder is evenly secured over the boss.
4. After installing the shock absorber valve O-ring (7), install the shock absorber valve assembly (6) snugly onto the adapter plate.
5. Lubricate the outside of the end of the bladder, which is affixed to the adapter plate, with a suitable lubricant. Then, slide the bladder adapter plate assembly into the dampener screen (5). There should be a snug fit between the open end of the screen and the bladder.
6. Stand the dampener housing (4) on end. Place the four-inch clamp gasket (2) on the dampener housing ferrule. Insert the dampener screen into the dampener housing and center the supporting ring in the gasket. Assemble the clamp sub-assembly over the ferrule. Assemble the bolts and nuts and tighten.

Installation

The dampener assembly should be installed as close as possible to the discharge of the homogenizer or pump. The product flow must enter the end of the dampener housing and discharge out the side.

CAUTION: When used with product line pressures in excess of 200 psig, a Tri-Clover 13-MHP high pressure clamp must be used. Do not use high-pressure clamps of other manufacture, as they are not compatible with the dampener ferrules and serious damage or injury could result.

!WARNING!
DO NOT EXCEED 300 PSIG LINE PRESSURE UNDER ANY CONDITION.
CONTACT FACTORY FOR SPECIAL MATERIALS.

Operation

1. Install an airline with a pressure-reducing valve and a tire-inflating chuck (available at auto supply stores) in close proximity to the dampener location.
2. Charge the bladder, using shop air, unless the product liquid is a hydrocarbon. If the liquid is a hydrocarbon, do not use oxygen or air for the gas pre-charge, because of the possibility of diesel-type combustion in the event of a bladder rupture. Use nitrogen or another inert gas, instead. There are two good ways to determine the pre-charge pressure for systems operating at a single discharge pressure. In order of practicality they are:
 - a. Pre-charge to 60% of the system pressure but do not exceed 100 psig. If 100 psig is exceeded, the bladder will have a tendency to extrude through the screen when the liquid pressure is absent.
 - b. Pre-charge bladder to 100 psig. Then, while operating the system, gradually decrease the pre-charge pressure, until the system noise and vibration are at a minimum. This means stopping the flow and discharge pressure at intervals and checking the pre-charge pressure to be sure that it does not drop lower than one-third of the discharge pressure.

For systems operating with two discharge pressures, adjust the pre-charge pressure, as described below:

Example: For a High-Temperature-Short-time (HTST) pasteurizing system with a 125 psig discharge processing pressure and a 50 psig Clean-In-Place (CIP) processing pressure, use a 40-45 psig air pre-charge pressure. The rationale is that the pre-charge pressure must be at least a little less than the CIP pressure of 50 psig for cleaning purposes and to provide some dampening during CIP. Also, the pre-charge pressure should be no less than one-third of the processing pressure of 125 psig.

Note: The gas volume of the dampener is 188 cubic inches when charged.

3. Because minor air leakage could occur from the valve, be sure to install the stem cap.
4. Check the bladder pressure once a week and recharge as needed.

CAUTION: Do not connect a permanent airline to the dampener or attempt to check the pressure during operation. The bladder pressure during operation will be the same as the backpressure in the system.

Disassembly

To prevent injury, release all air pressure from the bladder before disassembling the unit. Then, proceed in the reverse order shown in the assembly instructions.

Part No. 898122

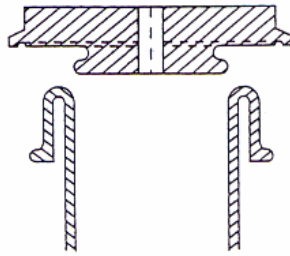

FIGURE 1
OLD STYLE

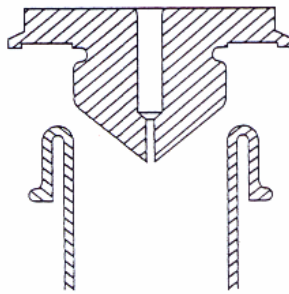
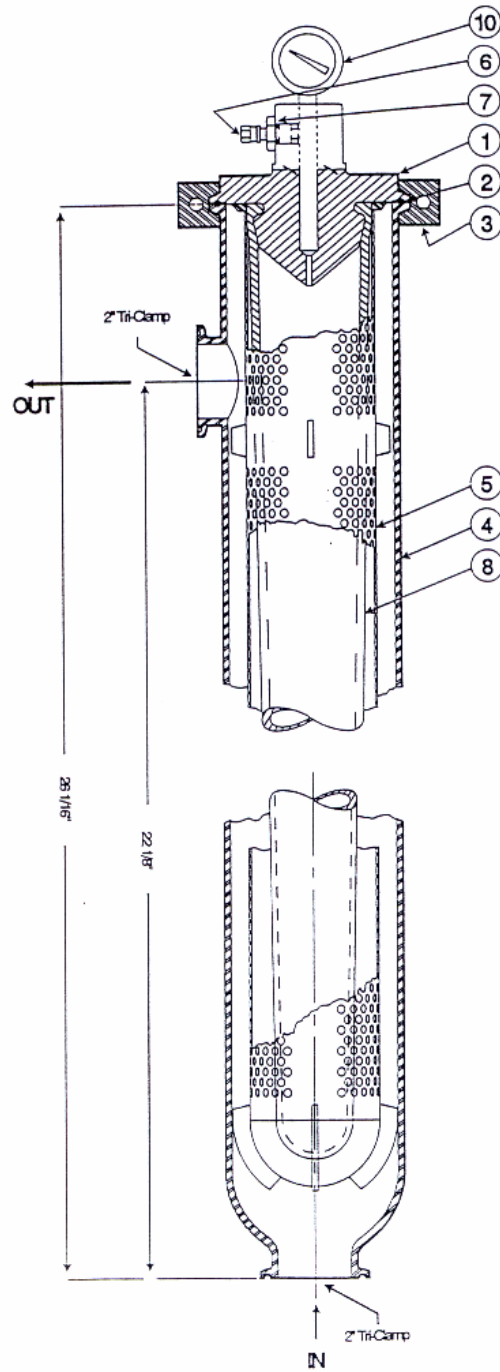

FIGURE 2
NEW STYLE

See Assembly Instruction #3. The "folded" end of the Bladder is held against the boss of the Adapter Plate, and then is unfolded over the boss.

ITEM	DESCRIPTION
1.	ADAPTER PLATE
2.	CLAMP GASKET
3.	CLAMP SUB-ASSEMBLY
4.	DAMPENER HOUSING
5.	DAMPENER SCREEN
6.	SHOCK ABSORBER VALVE ASSEMBLY
7.	SHOCK ABSORBER VALVE O-RING
8.	BLADDER*
9.	PATENT IDENTITY STICKER
10.	0-160 PSI PRESSURE GAUGE

* SECOND BLADDER PROVIDED AS A SPARE.



APV, An SPX Brand
 Phone: 1-888-278-4321
 Email: answers.us@apv.com

For more information about our worldwide locations, approvals, certifications, and local representatives, please visit www.apv.com.

SPX reserves the right to incorporate our latest design and material changes without notice or obligation. Design features, materials of construction and dimensional data, as described in this bulletin, are provided for your information only and should not be relied upon unless confirmed in writing. Certified drawings are available upon request.