



Instruction Manual



Form No.: 453342 USA

Revision: 07.2011

Read and understand this manual prior
to operating or servicing this product.



W+
Centrifugal Pump



Section	Page	Description
-	1	Introduction
-	3	Warnings
-	6	Important Warnings
-	8	Sectional Drawing
1	10	Introduction to the W+
1.1	-	W+ range
1.2	-	W+ pump features
1.3	-	Identifying the pump model
2	11	Installation of the pump
2.1	-	Positioning
2.2	-	Lining up the pipe system
2.3	-	Power supply
2.4	-	Water supply for water-flushed shaft seal
2.5	12	Connecting steam or steam condensate for aseptic use
3	12	Before start-up
3.1	-	Checking the pump body for foreign material
3.2	-	Testing the pump
4	13	Putting the pump into service
4.1	-	Flushing water/steam/condensate etc.
5	13	Maintenance
5.1	-	Checking the shaft seal
5.2	-	Replacing the shaft seal
5.3	15	Replacement of motor
5.4	16	Recommended spare parts
6	17	Technical data
6.1	-	Maximum permissible outlet pressure
6.2	-	Required torques

Spare parts, see separate Spare Parts Lists



Introduction

Congratulations, you are the owner of a quality built item from SPX Flow Technology. This pump was manufactured by the skilled personnel of a company which has served the needs of the dairy, food and process industries for more than 100 years.

The purpose of this manual is to provide instructions for the safe installation, operation and maintenance of your SPX Flow Technology equipment.

Read and understand the entire manual before removing from the crate and installing the equipment.

SPX Flow Technology is committed to providing quality equipment and customer satisfaction. We have a unique network of sales and service support throughout the world which are listed in this manual. Please note the office located nearest to you. Should you have any questions concerning any information contained in this manual, contact SPX Flow Technology in Delavan, WI at 1-800-252-5200 for assistance.

Standard Warranty

Obligations of Seller

During the warranty period, the Seller shall repair, or at Seller's option, replace parts determined by the seller to be defective in material or workmanship. The warranty period is one (1) year from the date of delivery to Buyer F.O.B. point of manufacture. The foregoing shall be the sole obligation of the seller under this warranty with respect to the equipment and the other property included in this agreement. With respect to the equipment, materials, parts and accessories manufactured by others, seller's sole obligation shall be to use reasonable efforts to obtain for the Buyer the full benefit of the manufacturer's warranties

Warranty Exclusions

Repair or replacement of parts required because of misuse, improper care or storage, negligence, alterations, accident, use of incompatible supplies or lack of specified maintenance are excluded from the Seller's warranty obligations.

Disclaimer of Warranties

The foregoing warranty expressions are in lieu of all other warranties, expressed or implied, including implied warranties of merchantability and fitness for a particular purpose, and existence of any such other warranty is hereby denied.

Limitation of Liability and Remedies

The liability of the Seller for breach of any warranty obligation hereunder is limited to:

1. The repair or replacement of the equipment on which the liability is based or,
2. At the Seller's option, the refund to the Buyer of the amount paid by the Buyer to the Seller for said equipment.



Introduction

All other liability of the Seller with respect to this agreement, or from the manufacture, installation, maintenance, repair or use of any equipment covered by or furnished under this agreement, whether in contract or in tort, or otherwise, is limited to the amount paid by the Buyer to the Seller pursuant to the terms herein:

Seller shall not be liable for incidental or consequential damages of any kind whatsoever. The remedies set forth herein are exclusive.

Breach

Any breach by the Seller with respect to any items or unit of equipment shall be deemed a breach with respect to that item or unit only.

Infringement

The Seller will not be liable for the infringement of any patent by the Buyer's use of any equipment or materials delivered hereunder.

A word about SPX Flow Technology Service Parts

We want to raise your awareness to the problem associated with the purchase of parts not manufactured to the high quality specifications of SPX Flow Technology.

In addition to our high quality, SPX Flow Technology parts are manufactured to meet regulatory agency authorization, approvals and certification (3A Sanitary standards, USDA, ASME, BISSC, and OSHA). Where applicable, materials used in construction of SPX Flow Technology parts conform to FDA regulations.

Types of equipment include, but are not limited to rotary pumps, centrifugal pumps, homogenizers, scrape surface heat exchangers and plate heat exchangers.

We bring this potentially serious problem to your attention in order to safeguard your best interest and those of your employees.

If you have any questions, please feel free to call your local SPX Flow Technology contact.



Warnings

Parts not manufactured to our specifications may cause damage to your SPX Flow Technology equipment and void all warranties. Use of parts that do not meet SPX Flow Technology specifications may cause property damages and serious bodily injury.

Policy regarding availability of service parts

SPX Flow Technology will attempt to remain in a position to supply replaceable parts during the normal life of any item of SPX Flow Technology equipment. This is contingent upon availability of tools, material and facilities of our own as well as of our suppliers.

After the expiration of this period, the supply of service parts will be limited to available stock of completed parts. If unable to supply the service part, drawings will be furnished when available to permit local manufacturing, if desired.

SPX Flow Technology reserves the right to improve, change or modify the construction of its equipment or any parts thereof without incurring any obligation to provide like changes to equipment previously sold.

Safety Information

Electrical Hazard

A pump is normally powered by an electric motor. This creates a hazard of electrical shock which could cause severe injury or even loss of life.

To minimize the risk of this hazard:

All electric/electronic installation, maintenance, and service must be performed by trained and authorized electricians only.

All electric/electronic installation must comply with all applicable codes and standards including those established by OSHA (Occupational Safety and Health Administration).

Do Not perform any maintenance or service on the motor or any other electrical devices unless the electric power source has been turned off and Locked Out using a locking device for which only the person involved in the maintenance procedure has possession of the key.

Make installation suitable for a wet environment, including:

1. A power disconnect which can be locked in a power Off position and the key removed. This will allow maintenance or service to be performed without possibility of power being accidentally turned on.
2. Protection of all electric connections within a sealed junction box.
3. Proper grounding of the motor.
4. Protection from flooding. Do not install in an area which could fill with water to a level which contacts the motor.

Warnings

Rotating Parts Hazard

Routine cleaning and maintenance procedures require pump disassembly. The pump contains close fitting parts which rotate during operation. Should the pump start unexpectedly while disassembled, severe injury could result.



To minimize the risk of this hazard:

1. Do Not assemble or disassemble the pump
2. Do Not remove the guard from the adapter
3. Do Not perform any maintenance or service on the motor or pump unless the power source has been turned off and Locked Out, where only the person involved in the maintenance procedure has possession of the key.

High Temperature Hazard

Some pump applications may require processing of high temperature liquids and/or the use of high temperature cleaning/sanitizing solutions. Pumping high temperature liquids is considered to be hazardous and extreme care should be taken when handling such liquids.

To minimize the risk of this hazard:

1. All installation, maintenance and service of piping, valves and other controls must be performed by trained and authorized plumbers only. This applies to process piping and cleaning/sanitizing piping.
2. All plumbing installation must comply with all applicable codes and standards including those established by OSHA.
3. Do Not perform any maintenance or service on the motor or pump unless the power source has been turned off and Locked Out, where only the person involved in the maintenance procedure has possession of the key.
4. Never disconnect any lines or fittings (whether process or cleaning/sanitizing) or disassemble the pump until the line is no longer under pressure and the fluid inside is not hot or harmful.
5. Operating personnel must be authorized and trained.



Warnings

High Pressure Hazard

Fluids processed by a pump are under pressure. This creates a hazard to personnel working in the area should a leak occur. Leaking high pressure fluid may cause injury by startling personnel or from actual contact with the leaking fluid.

To minimize the risk of this hazard:

1. All installation, maintenance and service of piping, valves and other controls must be performed by trained and authorized plumbers only. This applies to process piping and cleaning/sanitizing piping.
2. All plumbing installation must comply with all applicable codes and standards including those established by OSHA.
3. Never disconnect any lines or fittings (whether process or cleaning/sanitizing) or disassemble the pump when lines are under pressure.
4. Should a leak occur, immediately find the cause and stop the leak.

Explosion Hazard

Never operate the pump with both the inlet valve and the outlet valve in closed positions. If the pump runs with liquid in it, while the valves controlling the suction and discharge lines are both closed, the liquid in the pump will heat up and turn into vapor, causing a risk of explosion.

To eliminate the risk of explosion, it is strongly recommended that the following be included in the system:

1. A pressure relief device which relieves pressure and contains any discharge, or
2. A thermal/pressure overload device to isolate the pump motor in the event of excessive temperature/pressure.

Leaking Fluid Hazard

Fluid leaks or spills may occur in any pumping system. This creates a hazard to personnel due to slippery floor conditions or contact with possibly hazardous fluids.

To minimize the risk of this hazard:

1. Always clean up leaks and spills immediately.
2. Find and correct the cause of the leak immediately.



Important Warnings

The following important cautions describe ways to avoid incorrect operating procedures which will cause serious damage to the pump.

Cavitation

Cavitation is a condition within the pump which results in extreme hydraulic forces which can create a risk of severe damage to pump components. Cavitation makes a characteristic "rattling" noise. It is caused by operation with low fluid pressure at the pump inlet.

To minimize this risk:

Install and operate the pump so that NPSH (net positive suction head) available to the pump equals or exceeds the "NPSH required" as shown on the pump performance curve. To increase NPSH available:

1. Decrease the temperature of the liquid being pumped.
2. Increase the height of liquid supply level.
3. Decrease the suction line length and remove restrictions to flow such as elbows, valves, etc.
4. Increase the suction line size (diameter).
5. Reduce the pump flow rate (throttle discharge).

Corrosion Pitting

Stainless steel is subject to a risk of corrosion when improperly cleaned or sanitized.

To minimize this risk:

1. Never use steel wool or a wire brush to clean stainless steel surfaces. Iron particles will embed and cause corrosion pits. Use a non-metallic brush or scrub pad for cleaning when required.
2. Never allow prolonged contact of sanitizing solutions or other corrosive cleaning chemicals with stainless steel. Only use sanitizing solutions immediately prior to processing.

Important Warnings

Motor Overload

Depending on the impeller diameter and motor horsepower, there is a risk the pump motor will overload if operated with a fully opened, unrestricted discharge.

To minimize this risk:

1. Before operating the pump, review performance curve and application giving consideration to motor horsepower and impeller diameter versus expected discharge flow rate and pressure. If the pump is operated with less than expected discharge pressure, the flow rate will increase and the load on the motor will increase.
2. Install a throttling type valve in the discharge piping to allow control of pump discharge flow rate during initial operation. The valve may be removed later when the system is proven to supply adequate discharge pressure to prevent overload.

Impeller Shaft Location

The location of the impeller shaft on the motor shaft is critical for correct pump operation and to obtain maximum operating efficiency.

APV Centrifugal Pumps are designed to achieve excellent operating efficiency. This efficiency is possible, in part, because of precision manufacturing of the pump components. The impeller must be precisely located between the casing and backplate to take full advantage of the pump's operating efficiency.

Incorrect location of the impeller shaft may cause the impeller to contact the casing or the backplate during operation and cause extensive damage to the pump.

The procedures for correctly locating the impeller shaft are described in the Maintenance section. This should be referred to whenever:

1. A new pump is installed onto a motor or pedestal.
2. The impeller shaft is loosened or removed from the motor or pedestal shaft.
3. A replacement casing or backplate is installed.

Sectional Drawing

W+

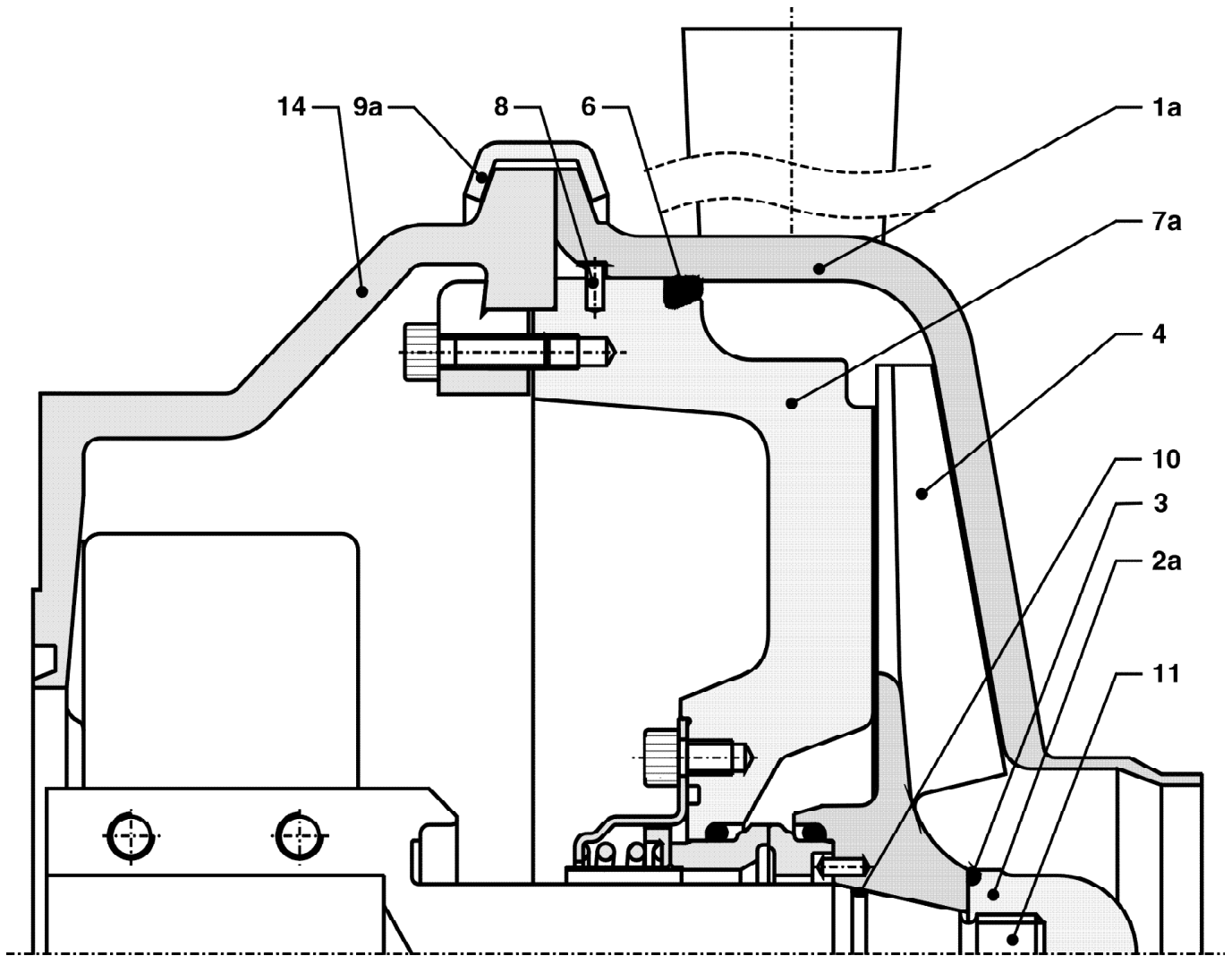

Section 1

Shaft size $\varnothing 25$ and $\varnothing 35$

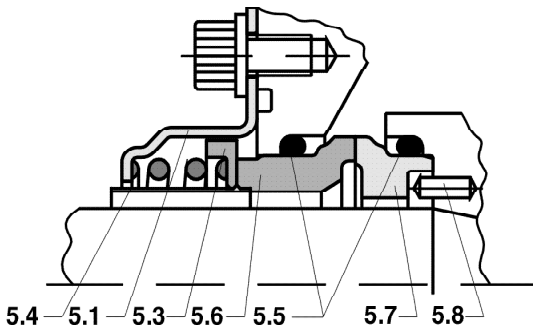

Section 2

Shaft size $\varnothing 25$ and $\varnothing 35$

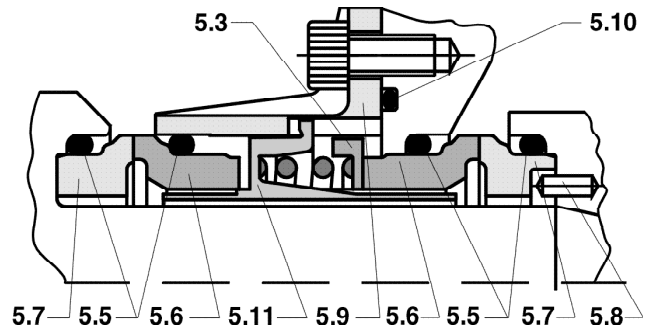

Sectional Drawing

W+

1a:	Pump housing
2a:	Cap nut
3:	O-ring
4:	Impeller
6:	O-ring
7a:	Back plate
8:	Locating pin
9a:	Clamp ring
10:	O-ring
11:	Shaft
14:	Motor adaptor

Section 1 Single seal for shaft size $\varnothing 25$ and $\varnothing 35$

Section 2 Double seal with liquid/steam flushing for shaft size $\varnothing 25$ and $\varnothing 35$

5.1:	Seal housing
5.3:	Pressure ring
5.4:	Drain pipe
5.5:	O-rings
5.6:	Stationary seal face
5.7:	Rotary seal face
5.8:	Pin
5.9:	Seal housing
5.10:	O-ring
5.11:	Pressure ring



1. Introduction to the W+ program

1.1 The W+ range

This manual covers all the standard versions of the W+ pump as well as aseptic versions (Wa+ pumps) and pumps with inducer (Wi+ pumps). Check the pump's nameplate to make sure that you have one of the above versions. The WHP+ and W+140/50 pump versions are described in a separate manual which will come with the pump. The WK+ (pedestal pump version) is described in a supplementary manual.

Units are designed and constructed to meet the requirements of the 3A sanitary standards for cleanability of processing equipment.

1.2 The W+ pump features

Standard Options are available in the W+ range:

- with frame and feet
- with shaft seal in carbon/SiC or SiC/SiC
- with o-rings in EPDM or FPM (Viton) (Kalrez and possibly others)
- with single or double shaft seal prepared for water-flushed or steam-flushed shaft seal

Additional Options:

- Heating/Cooling Jacket
- Casing Drain
- Portable 2- and 3-wheel cart
- Inducer (Wi+)
- Double o-ring sealing of pump body fitted for sterile flushing (Wa+)
- Heavy duty clamp ring, increasing the pump's maximum permissible outlet pressure to 360 PSIG (available for W+30/120, W+55/35, W+55/60, W+60/110, W+70/40) or 290 PSIG (available for W+80/80).
- W+ pumps can be supplied with all standard welded ferrules (tri-clamp, bevel seat, ISO, etc.) or with special aseptic connections prepared for sterile flushing (Wa+).

1.3 Identifying the pump model

A nameplate as is fitted on the motor adaptor.

Example:

Serial No.: Use the serial number whenever requesting information on service parts.

Type: The type indicates the type of pump, such as W+10/8, W+22/20, etc.

Year: Indicates the year of manufacture.

Order No.: Indicates the number the pump was ordered under.



2. Installation of the Pump

2.1 Positioning

The pump must be positioned so that the suction pipe is as short as possible and there is a sloping gradient towards the suction port. Keep the number of valves, bends and tee-pieces on the suction side to an absolute minimum. There must be sufficient space around the pump for piping and access for maintenance.

2.2 Lining up the pipe system

Line up the pipes carefully to the pump suction and discharge nozzles. Make sure that the pipe system is adequately supported by pipe supports so that the pump body is not subject to strains and weight from the pipe system.

2.3 Power supply

All electrical installation must comply with all applicable codes and standards including those established by the Occupational Safety and Health Administration (OSHA).

Install a main power disconnect on-off switch that can be locked in the power off position and have the key removed when service is performed.

Thoroughly read the motor manufacturer's instructions before making installation.

The motor should be connected such that the direction of rotation of the motor (and thus the impeller) is counterclockwise when viewed from the front towards the suction nozzle of the pump body (Fig. 1).

2.4 Water supply for water-flushed shaft seal

Pumps with a water-flushed shaft seal have two hose connectors on the seal flange. The hose connectors are 1/8 inch NPT and fit a 1/4 inch plastic tubing. A flush flow of 4-8 gallons/hour is required. Maximum pressure is 100 PSIG.

The hose connection in the seal flange should always be positioned vertically with the fluid inlet below and the outlet above. See Fig. 2.

Water consumption can be limited by installing a solenoid valve on the supply side for the flushing water. The open/close function of the solenoid valve can be controlled by the pump's start/stop sequence.

Do not use the flushing water connectors for steam condensate. If you want to use steam as the barrier medium, special aseptic piping is required. See section 2.5 for connection.

Fig. 1: Direction of shaft rotation

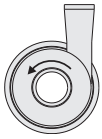
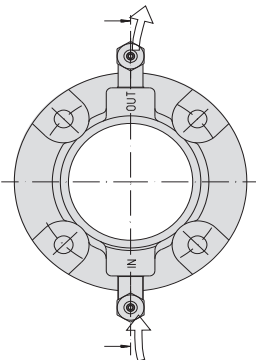
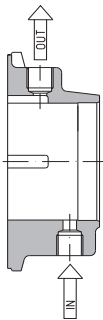

Fig. 2





2. Installation of the Pump

2.5 Connecting steam or steam condensate for aseptic use

Shaft seals for aseptic use are supplied with stainless steel connectors (18" NPT x 1/4" Tube).
 The connection for steam or steam condensate with a static double seal in the pump body is supplied with stainless steel fittings (1/8" NPT x 1/4" Tube) and 1/4" stainless steel tubing.
 Steam can be used at temperatures up to 300°F (150°C) and pressures up to 72 PSIG (5 bar).

3. Before Start-up

Before starting the pump, dismantle and clean the suction pipe. Any foreign material in the pump should be removed.

3.1 Checking the pump body for foreign material

Remove the pump body as described below. The assembly drawing is to be used for reference (page 8).

1. Disconnect the power supply.
2. Remove the pump body (item 1a) by undoing the clamp ring (item 9a) or body screws and carefully pull off the pump body.
3. Turn the impeller (item 4) to ensure that there is no foreign material behind it.
4. If there is any foreign material in the pump, remove it.
5. When the pump body is clean and free of foreign material, reassemble the pump.

Mount the pump body as described below:

6. Check that the locating pin (item 8), where fitted, in the top of the back plate mates with the detent in the pump body and carefully, to avoid damaging the o-ring, press the pump body (item 1a) in over the o-ring (item 6) and fasten with the clamp ring (item 9a) or body screws, observing the correct tightening torque.

M8:	22 ft-lb	(30 Nm)
M10:	41 ft-lb	(55 Nm)
M12:	80 ft-lb	(59 Nm)

7. Install suction and discharge pipes. Check that the pipe unions have been tightened properly and that pipe supports have been fitted.

To make the pump body easier to fit, we recommend that you give the o-ring a thin layer of food-approved, acid-free grease or soap.

3.2 Testing the pump

To check that the pump is working satisfactorily, pour water into the pump and start it for a moment. Check the direction of rotation (fig. 3). Listen for any unusual noises.

In pumps with water-flushed or steam-flushed shaft seals, the seal chamber must be filled with water/steam.

Never allow the pump to run without liquid, as this will ruin the shaft seal.



Fig. 3: Direction of rotation

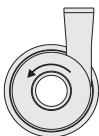

4. Putting the Pump into Service

Check the following before starting the pump:

- that the shaft guard has been fitted properly
- that there is free access for liquid
- that the valve on the discharge side is closed.

The valve on the discharge side (if fitted) is closed during start-up to reduce motor starting current, but should be opened again as soon as the pump has been started.

4.1 Flushing water/steam/condensate etc.

In pumps with a flushed shaft seal, check that the supply of flushing medium is open and that the flow of the medium is adequate (approx. 4-8 gallons/hour).

5. Maintenance

5.1 Checking the shaft seal

Check the pump's shaft seal for leaks on a regular basis. If the shaft seal is leaking, replace it or its relevant parts as described below.

5.2 Replacing the shaft seal

The assembly drawing shows the position and construction of the shaft seal - both standard seals and seals with water/steam flushing.

Dismantling the pump

To replace the shaft seal, it is necessary to dismantle the pump as described below. The assembly drawing on page 8 is to be used for reference.

1. Disconnect the power supply in the motor isolator by removing the fuses and disconnecting the cables.
2. Turn off the steam and flushing water supply.
3. Close the inlet and discharge of the pump, and make sure that there is no liquid in the pump body.



If the pump is used for hot and/or aggressive liquids, special precautions must be taken. In such cases, observe the local regulations for personal protection when working with these products.

Dismantling the shaft seal

4. Once the inlet and outlet pipes have been closed properly, release the clamp ring (item 9a) or body screws, take off the pump body (item 1a) and remove the impeller (item 4).
5. Remove the stationary seal face (item 5.6) mounted in the back plate (item 7a) with your fingers.
6. Remove the o-ring (item 5.5) from the stationary seal face.
7. Use your fingers to remove the rotary seal face (item 5.7) mounted in the impeller (item 4).

5. Maintenance

Checking parts for wear



Fitting

Positioning the water supply connections

8. Remove the o-ring (item 5.5) from the rotary seal face.
9. Clean the stator and rotary seal face locations, if necessary with air or water.
- 9a. In the case of water-flushed/aseptic shaft seals, the back plate must be removed to dismantle the rear shaft seal. The rear seal stationary seal face (item 5.6) is mounted in the pressure ring (item 5.11) and the rotary seal face (item 5.7) is mounted on the shaft (item 11). These are removed in the same way as the front seal components.
10. Check o-rings (item 5.5) for signs of cracks, lack of elasticity, brittleness and/or chemical attack. Replace worn or defective parts.
11. Check the stationary seal face (item 5.6) and rotary seal face (item 5.7) for signs of wear too. The wearing surfaces must be completely free of scratches/cracks. If not, the rotary seal face and stationary seal face must both be replaced.
- 11a. In the case of water-flushed shaft seals, check the rear seal rings (item 5.7, 5.6) for wear too, and replace if necessary.
12. Fit new o-rings on the stationary seal face (item 5.6) and rotary seal face (item 5.7). Take extra care not to leave finger prints or contaminates on the seal faces during assembly.
Note. Remember to moisten these with water.
13. Fit the rotary seal face (item 5.7) on the impeller without using tools.
Note. The "notch" in the rotary seal face must be located so that it mates with the driving pin (item 5.8) in the impeller hub.
- 13a. In the case of water-flushed/aseptic seals, also fit a rotary seal face (item 5.7) with its o-ring (item 5.5) in the location on the shaft, again without using tools.
14. Fit drain pipe (item 5.4) to the back of the stationary seal face (item 5.6). Fit the stationary seal face (item 5.6) on the back plate without using tools.
Note. The "notches" in the stationary seal face must mate with the driving dogs on the carrier in the back plate. Check that the stationary seal face is positioned so that it slides backwards and forwards easily in the back plate.
- 14a. Where there are water-flushed/aseptic seals, fit the stationary seal faces (item 5.6) into the seal cover (item 5.9) and back plate (item 7a).
15. After fitting, clean the wearing surfaces.
- 15a. For liquid-flushed/aseptic seals, remount the back plate (item 7a).

5. Maintenance

16. Fit the impeller (item 4). Remember to use the proper tightening torque:

M10:	33 ft-lb	(45 Nm)
M14:	52 ft-lb	(70 Nm)
M20:	148 ft-lb	(200 Nm)



17. Check that the locating pin (item 8), where fitted, in the top of the back plate mates with the detent in the pump body and carefully, to avoid damaging the o-ring, press the pump body (item 1a) in over the o-ring (item 6) and fasten with the clamp ring (item 9a) or body screws, observing the correct tightening torque.

M8:	22 ft-lb	(30 Nm)
M10:	41 ft-lb	(55 Nm)
M12:	80 ft-lb	(59 Nm)

5.3 Replacement of motor

The standard motor for the W+ pump has a locked front bearing. If the motor is replaced, the new motor must also have a locked front bearing. The motor bearing is enclosed and permanently lubricated.

Follow the instructions below when replacing the motor. For replacement of bearings, see the motor supplier's service instructions.

Fig. 4: Unscrew motor flange bolts

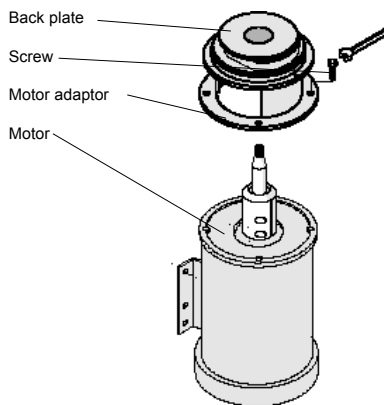

1. Lock Out power supply then disconnect the pump and motor from system.
2. Removal of the pump body. See para 5.2, points 1-4.
3. Remove the impeller.
4. If possible, stand the pump on end. See Fig. 4.
5. Undo the four motor flange bolts between the motor and motor adaptor and remove them. See Fig. 4.
6. Lift the back plate, motor adaptor and spacer flange (where fitted), which are still bolted together, up and off the shaft. See Fig. 4.
7. See Fig. 5. Loosen the screws in the base of shaft, pull the shaft off and replace the motor.
8. See Fig. 6. Before remounting the pump shaft, remove any dirt and grease from the motor shaft and the base's internal clamping surfaces. Mount the pump shaft loosely. Position the balance hole above the keyway.

Fig. 5: Loosen screws

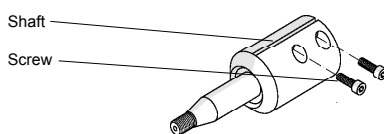
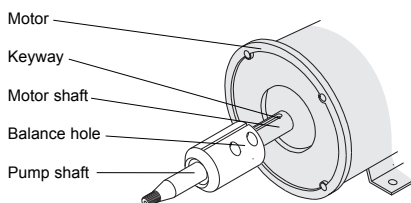

Fig. 6: Mount pump shaft



9. Fit the back plate and motor adaptor over the shaft.
10. Tighten the bolts.
11. Turn the pump back so that it stands on its legs.
12. Fit the impeller and secure it with the cap nut/inducer.

Remember to use the proper tightening torque:

M10:	33 ft-lb	(45 Nm)
M14:	52 ft-lb	(70 Nm)
M20:	148 ft-lb	(200 Nm)



5. Maintenance

Fig. 7: Place plastic star against impeller

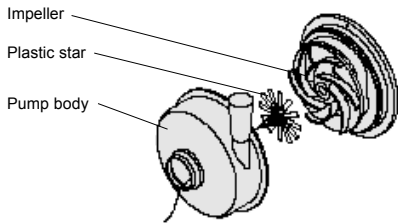
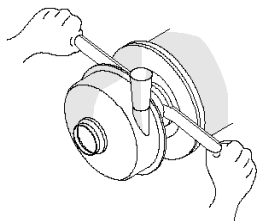

Fig. 8: Push shaft forward



13. Place the plastic star against the impeller. See fig. 7.
14. Fit the pump body (item 1a) with the clamp ring (item 9a).
15. Push the shaft (item 11) forward until the impeller (item 4) is touching the plastic star. See fig. 8.
16. Tighten the shaft screws. Remember to use the proper tightening torque:

M8:	22 ft-lb	(30 Nm)
M10:	41 ft-lb	(55 Nm)
17. Remove the star by pulling it out through the inlet.

5.4 Recommended inventory of spare parts

Seal set

We recommend that you keep both seal kits and service kits for the W+ pumps in stock. The seal kit for the W+ pump consists of the wearing parts of the pump, as specified on page 12 of the Spare Parts List for the W+ pump.

Service kit

The service kit is made up of a number of the main components of the pump which are not wearing parts, but which you still may have to replace: shaft, impeller, cap nut and fixing kit.

The table below shows the recommended inventory of spare parts for normal operation and in cases where there are special needs - for example 24-hour operation, operation with abrasive media or processes that are sensitive to even the shortest production stoppage.

Wearing parts (seal kit, see page 12 of the Spare Parts list for the W+ pump)

	No. of pumps in service		
	0-5	5-20	> 20
	Sets	Sets	Sets/ 10 pumps
Normal operation	2	3	1
Special needs	3	6	2

Service parts (shaft, impeller, cap nut, see page 8, fixing kit, see page 11 of the Spare Parts List for the W+ pump).

	No. of pumps in service		
	0-5	5-20	> 20
	Sets	Sets	Sets/ 10 pumps
Normal operation	0	1	1
Special needs	1	2	1

6. Technical data

6.1 Maximum permissible outlet pressure

The maximum pump outlet pressures specified below must not be exceeded (applies to water at 68°F/20°C).

Max. 260 psig (18 bar): W+10/8, W+22/20, W+30/80, W+35/55,
W+35/35, W+110/130

Max. 200 psig (14 bar): W+25/210, W+30/120, W+50/8, W+55/35,
W+55/60, W+60/110, W+65/350, W+70/40,
W+80/80

The above values also apply to the corresponding models in the Wa+ and Wi+ versions.

Subject to change.

6.2 Required torques

Required torques for the stub shaft screws						
Pump type	Shaft Ø	Motor type	shaft screw	required torques	Motor type	shaft screw
W+10/8	Ø25	80	M8x25	30 Nm	90-132	M8x30
W+22/20	Ø25	80	M8x25	30 Nm	90-132	M8x30
W+30/80	Ø25	90-160	M8x30	30 Nm	90-132	M8x30
W+35/35	Ø25	90-160	M8x30	30 Nm	90-132	M8x30
W+35/55	Ø25	90-160	M8x30	30 Nm	90-132	M8x30
W+50/8	Ø25	90-132	M8x30	30 Nm	90-132	M8x30
W+55/35	Ø25	90-160	M8x30	30 Nm	90-132	M8x30
W+25/210	Ø35	160-180	M8x30	30 Nm	90-132	M8x30
W+30/120	Ø35	90-180	M8x30	30 Nm	200	M10x40
W+55/60	Ø35	90-180	M8x30	30 Nm	200	M10x40
W+60/110	Ø35	90-180	M8x30	30 Nm	200-225	M10x40
W+65/350	Ø35	132-180	M8x30	30 Nm	200-280	M10x40
W+70/40	Ø35	90-180	M8x30	30 Nm	200	M10x40
W+80/80	Ø35	90-180	M8x30	30 Nm	200-250	M10x40
W+110/130	Ø35	100-180	M8x30	30 Nm	200-280	M10x40
W+50/600	Ø55	180-250	M12x40	80 Nm	280-315	M16x40
Ws+20/15	Ø25	90-160	M8x25	30 Nm	90-132	M8x30
Ws+30/30	Ø25	90-160	M8x25	30 Nm	90-132	M8x30
Ws+44/50	Ø35	132-180	M8x30	30 Nm	90-132	M8x30

Required torques for house clamp		
Pump type	mounting	Size
W+10/8	Clamp	M6
W+22/20	Clamp	M10
W+30/80	Clamp	M10
W+35/35	Clamp	M10
W+35/55	Clamp	M10
W+50/8	Clamp	M10
W+55/35	Clamp	M10
W+30/120	Clamp	M10
W+55/60	Clamp	M10
W+60/110	Clamp	M10
W+70/40	Clamp	M10
W+80/80	Clamp	M10
W+25/210	screws	M10x30
W+65/350	screws	M8x25
W+110/130	screws	M10x35
W+50/600	screws	M16x40
Ws+20/15	Clamp	M10
Ws+30/30	Clamp	M10
Ws+44/50	Clamp	M10

Required torques for cap nuts				
Pump type	Shaft Ø	Cap Nut	required torques	required torques
W+10/8	Ø25	M10	45 Nm	33 ft-lb
W+50/8	Ø25	M10	45 Nm	33 ft-lb
W+22/20	Ø25	M14	70 Nm	52 ft-lb
W+30/80	Ø25	M14	70 Nm	52 ft-lb
W+35/35	Ø25	M14	70 Nm	52 ft-lb
W+35/55	Ø25	M14	70 Nm	52 ft-lb
W+55/35	Ø25	M14	70 Nm	52 ft-lb
W+25/210	Ø35	M20	200 Nm	148 ft-lb
W+30/120	Ø35	M20	200 Nm	148 ft-lb
W+55/60	Ø35	M20	200 Nm	148 ft-lb
W+60/110	Ø35	M20	200 Nm	148 ft-lb
W+65/350	Ø35	M20	200 Nm	148 ft-lb
W+70/40	Ø35	M20	200 Nm	148 ft-lb
W+80/80	Ø35	M20	200 Nm	148 ft-lb
W+110/130	Ø35	M20	200 Nm	148 ft-lb
W+50/600	Ø55	M32	500Nm	370 ft-lb
Ws+20/15	Ø25	M14	70 Nm	52 ft-lb
Ws+30/30	Ø25	M14	70 Nm	52 ft-lb
Ws+44/50	Ø35	M20	200 Nm	148 ft-lb

Make sure that the key-groove of the motor shaft is to be seen through the hole in the stub shaft

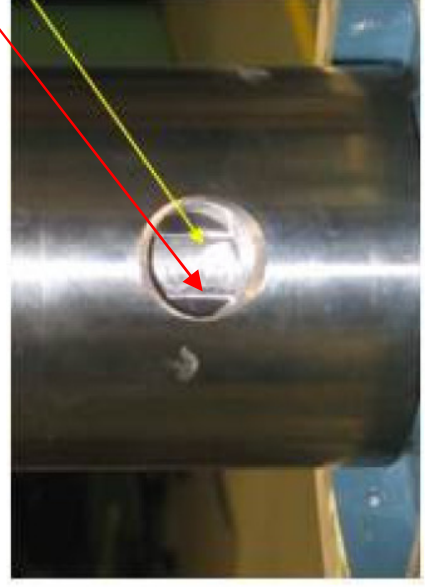

SPX Flow Technology
611 Sugar Creek Road
Delavan, WI 53115
Phone: (1) 800-252-5200



SPX reserves the right to incorporate our latest design and material changes without notice or obligation.

Design features, materials of construction and dimensional data, as described in this bulletin, are provided for your information only and should not be relied upon unless confirmed in writing. Please contact your local sales representative for product availability in your region. For more information visit www.spx.com.

“The green “>” is a trademark of SPX Corporation, Inc.”



Spare Parts List



Form No.: 453343 USA

Revision: 02

Read and understand this manual prior to operating or servicing this product.



W+
Centrifugal Pump



Table of contents

Pos.		Page
7.1	Pump Dimensions	2
7.2	Spare Parts List Compl.	7
7.3	Impeller	9
7.4	Shaft Seal	11
7.4.1	Fixing Kit	11
7.4.2	Face Kit	11
7.5	Seal Kit Compl.	12
7.6	Shaft	13
7.7	Motor adaptor with Shaft Guard	14
7.8	Frame	16



7.1 Pump Dimensions

W+

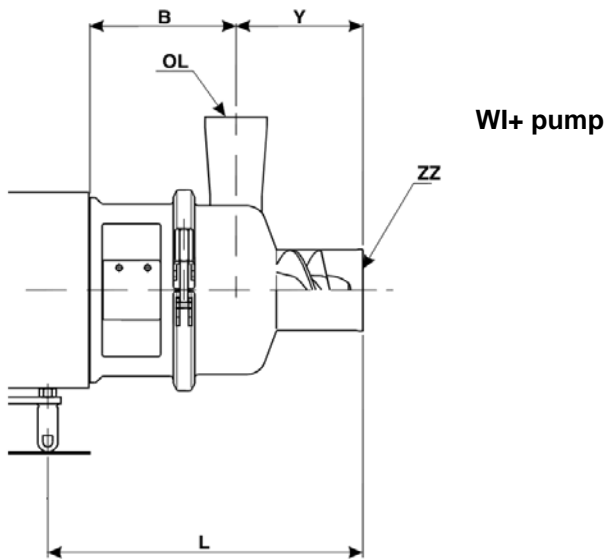
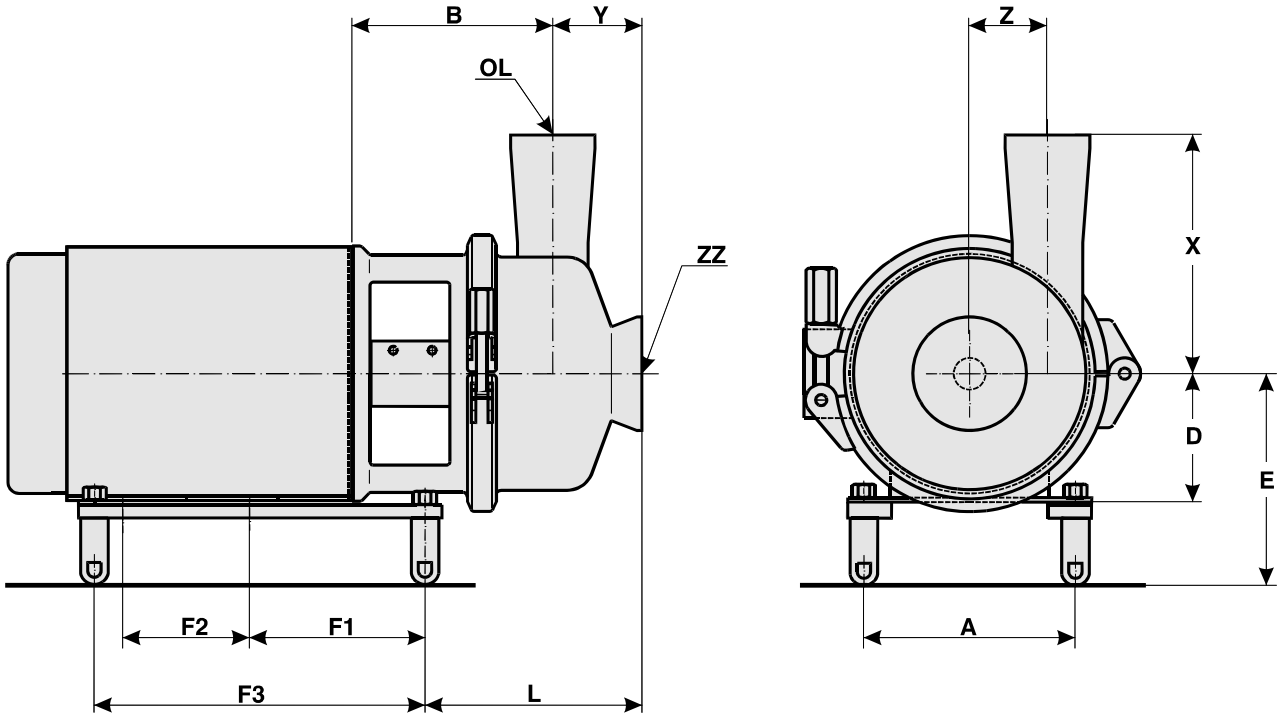

Inlet/Outlet Size	Bevel Seat	Threaded PV	TRI Clamp	APC Clamp	ISS	Male Pipe Thread	150#Flange
1.5" (38 mm)	0.687" (17 mm)	0.687" (17 mm)	1.125" (29 mm)	0.687" (17 mm)	1.125" (29 mm)	1.625" (41 mm)	1.187" (30 mm)
2.0" (51 mm)	0.750" (19 mm)	0.750" (19 mm)	1.125" (29 mm)	0.750" (19 mm)	1.125" (29 mm)	1.687" (43 mm)	1.187" (30 mm)
2.5" (63 mm)	0.844" (21 mm)	0.844" (21 mm)	1.125" (29 mm)	0.844" (21 mm)	1.125" (29 mm)	2.187" (55 mm)	1.187" (30 mm)
3.0" (76 mm)	0.906" (23 mm)	0.906" (23 mm)	1.125" (29 mm)	0.906" (23 mm)	1.125" (29 mm)	2.250" (57 mm)	1.500" (38 mm)
4.0" (102 mm)	1.000" (25 mm)	1.000" (25 mm)	1.125" (29 mm)	1.000" (25 mm)	0.844" (21 mm)	2.000" (51 mm)	1.500" (38 mm)
6.0" (152 mm)	N/A	N/A	1.500" (38 mm)	N/A	N/A	O/A	2.156" (55 mm)

7.6 Shaft

W+

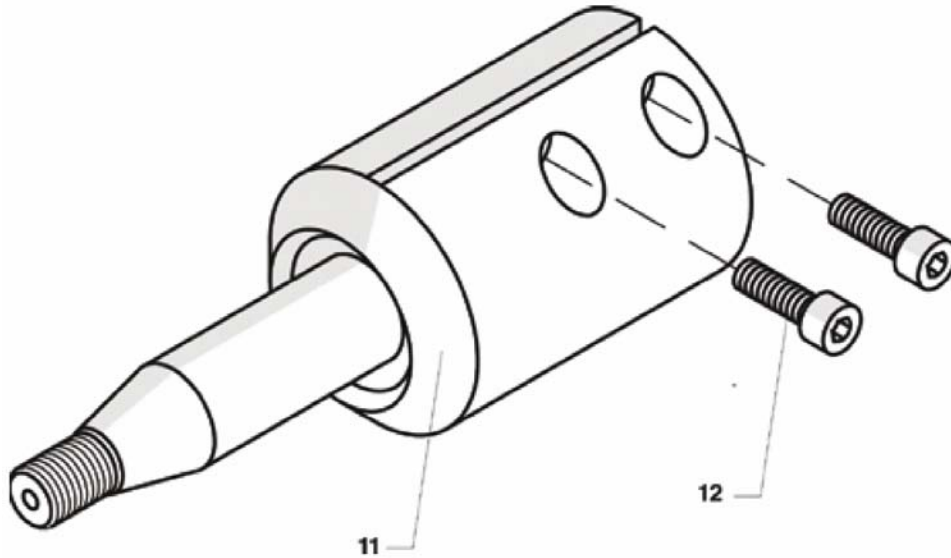

Pump Type	Motor								
	143-145TC	182-184TC	213-215TC	254-256TC	284-286TSC	324-326TSC	364-365TSC	405TSC	
	Pos. 11 Shaft Ø35								
W+25/210	----	----	----	----	L267342	L267343	L267343	----	
W+30/120	L267338	L267339	L267340	L267341	L267342	L267343	----	----	
W+55/60	L267338	L267339	L267340	L267341	L267342	L267343	----	----	
W+60/110	----	L267339	L267340	L267341	L267342	L267343	L267343	----	
W+65/350	----	----	L267340	L267341	L267342	L267343	L267343	L267357	
W+70/40	L267338	L267339	L267340	L267341	L267342	L267343	----	----	
W+80/80		L267339	L267340	L267341	L267342	L267343	L267343	L267357	
W+110/130	----	----	L267340	L267341	L267342	L267343	L267343	L267357	
	Pos. 12								
Qty.	2	2	2 2		2	2 2 2			
Screw	L771199	L771199	L771199	L771199	L771199	L701700	L701700	L701700	

Pump Type	Motor				
	56C	143-145TC	182-184TC	213-215TC	254-256TC
	Pos. 11 Shaft Ø25				
W+10/8	L267353	L267354	----	----	----
W+22/20	L267332	L267333	L267334	L267335	----
W+30/80	----	L267333	L267334	L267335	L267336
W+35/35	L267332	L267333	L267334	L267335	L267336
W+35/55	L267332	L267333	L267334	L267335	L267336
W+50/8	----	L267354	L267355	L267356	----
W+55/35	L267332	L267333	L267334	L267335	L267336
	Pos. 12				
Qty.	2	2	2	2 2	
Screw	L701942	L771199	L771199	L771199	L771199



7.7 Motor Adaptor and Shaft Guard

W+

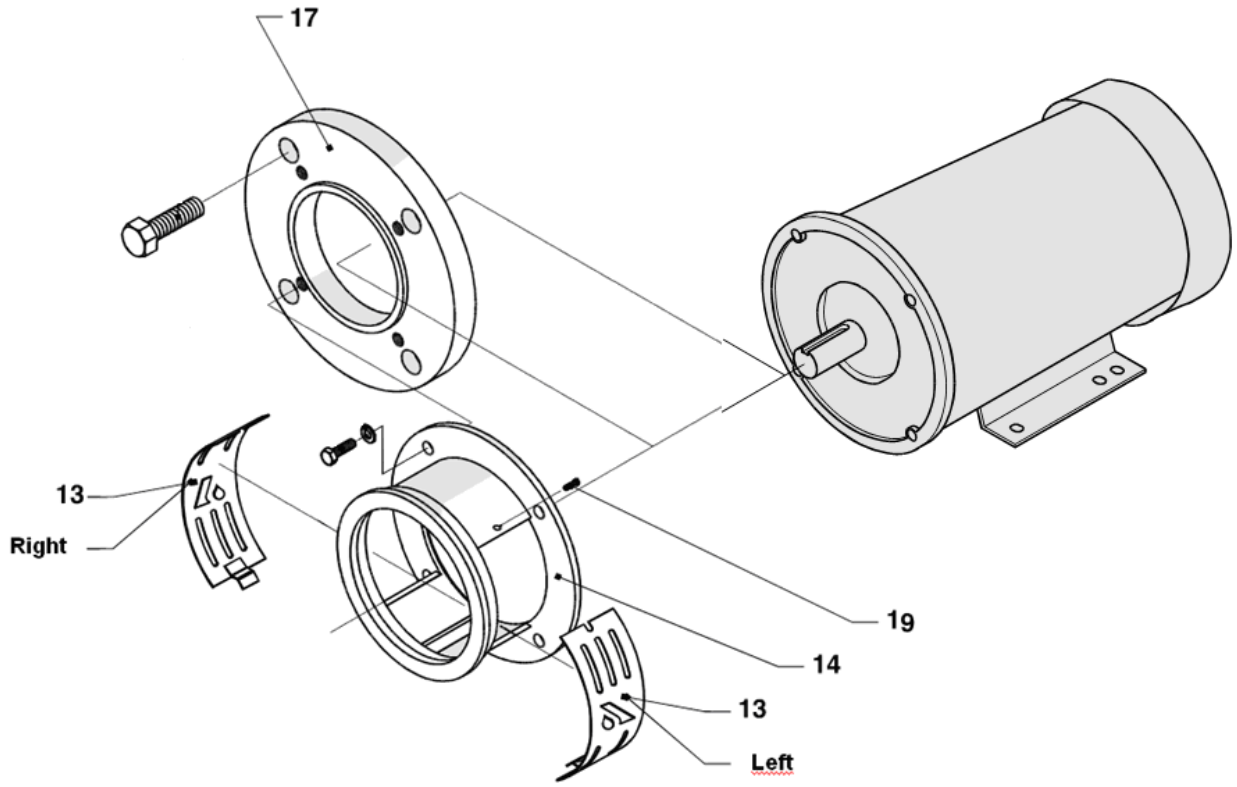

Pump Type	Motor								
	56C	143-145TC	182-184TC	213-215TC	254-256TC**	284-286TSC	324-326TSC	364-365TSC	405TSC
	Pos. 14 Motor Adaptor								
W+10/8	L273976#	L273976#	---	---	---	---	---	---	---
W+22/20	L260973#	L260973#	L260973#*	L260973#*	---	---	---	---	---
W+30/80	L260974	L260974	L260975	L260975	L260975	---	---	---	---
W+25/210	---	---	---	L168688	L168688	L168689	L168690	L168690	---
W+35/35	L260974	L260974	L260975	L260975	L260975	---	---	---	---
W+35/55	L260974	L260974	L260975	L260975	L260975	---	---	---	---
W+30/120	---	L260976	L260977	L260977	L260977	L260978	L260978***	---	---
W+50/8	---	L267363	L267364	L267364	---	---	---	---	---
W+55/35	L260976	L260976	L260977	L260977	L260977	---	---	---	---
W+55/60	---	L260976	L260977	L260977	L260977	L260978	L260978***	---	---
W+60/110	---	---	L260979	L260979	L260979	L260980	L260980***	L260980***	---
W+65/350	---	---	---	L168691	L168691	L168692	L168693	L168693	L168693
W+70/40	---	L260982	L168680	L168680	L168680	L168681	L168681***	---	---
W+80/80	---	---	L260981	L260981	L260981	L168683	L168682	L168682	L168682
W+110/130	---	---	---	L168684	L168684	L168685	L168686	L168686	L168686

integrated in back plate pos. 7b

Pos. 17 Flange Adaptor								
*	---	---	*L267095	*L267095	---	---	---	---
**	---	---	---	---	**L267096	---	---	---
***	---	---	---	---	---	---	***L267097	***L267097



7.7 Motor Adaptor and Shaft Guard

W+

Pump Type	Qty	Motor								
		56C	143-145TC	182-184TC	213-215TC	254-256TC	284-286TSC	324-326TSC	364-365TSC	405TSC
		Pos. 13 Shaft Guard								
W+10/8	2 R/L	L188815	L188815							
W+22/20	2 R/L	L188334	L188334	L188334	L188334					
W+30/80 W+35/35 W+35/55	1 R	L188333	L188333							
	1 L	L188285	L188285							
	2 R/L			L188653	L188653	L188653				
W+25/210	2 R/L				L279838	L279838	L188812	L188812	L188812	
W+30/120	1 R		L188339							
	1 L		L188597							
	2 R/L			L188653	L188653	L188653	L188811	L188811		
W+50/8	1 R		L188339							
	1 L		L188597							
	2 R/L			L188653	L188653					
W+55/35	1 R	L188339	L188339							
	1 L	L188597	L188597							
	2 R/L			L188653	L188653	L188653				
W+55/60	1 R		L188339							
	1 L		L188597							
	2 R/L			L188653	L188653	L188653	L188811	L188811		
W+60/110	1 R			L188819	L188819	L188819				
	1 L			L188822	L188822	L188822				
	2 R/L						L188816	L188816	L188816	
W+65/350	2 R/L				L188653	L188653	L188653	L188817	L188817	L188817
W+70/40	1 R		L188284	L188827	L188827	L188827				
	1 L		L188283	L188828	L188828	L188828				
	2 R/L						L188825	L188825		
W+80/80	1 R			L804738	L804738	L804738	L804753	L188823	L188823	L188823
	1 L			L804739	L804739	L804739	L188826	L188824	L188824	L188824
	2 R/L									
W+110/130	2 R/L				L188653	L188653	L188811	L188812	L188812	L188812

Pos	Qty.	Motor								
		56C	143-145TC	182-184TC	213-215TC	254-256TC	284-286TSC	324-326TSC	364-365TSC	405TSC
		Part No.								
19	2	L700420	L700420	L700420	L700420	L700420	L700420	L700420	L700420	L700420



7.8 Frame

W+

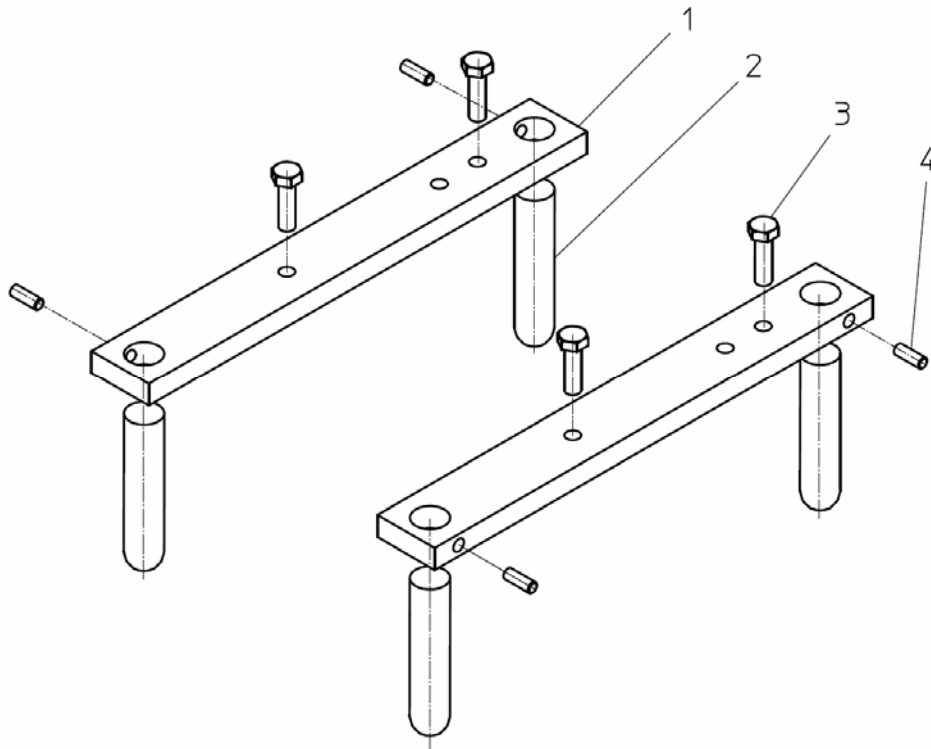

Pos	Qty	Description	Motor								
			56C	143-145TC	182-184TC	213-215TC	254-256TC	284-286TSC	324-326TSC	364-365TSC	405TSC
--	--	Frame cpl.	L114365	L110256	L110255	L110254	L110253	L110252	L110251	L110251A	
1	2	Side bar	L114364	L110262	L110261	L110260	L110259	L110258	L110257	L110257A	
2	4	Leg 3/4"	L110264				---				
2	4	Leg 1"	---				L110263				
3	4	Screw	5/16-18 x 3/4		3/8-16 x 1		1/2-13 x 1 1/8		5/5-11 x 1 1/4		
4	2	Screw	1/4-20 x 1/2 SQ.HD				1/4-20 x 5/8 SQ.HD				

SPX Flow Technology
611 Sugar Creek Road
Delavan, WI 53115
Phone: (1) 800-252-5200



SPX reserves the right to incorporate our latest design and material changes without notice or obligation.

Design features, materials of construction and dimensional data, as described in this bulletin, are provided for your information only and should not be relied upon unless confirmed in writing. Please contact your local sales representative for product availability in your region. For more information visit www.spx.com.

"The green ">" is a trademark of SPX Corporation, Inc."