

# Instruction Manual W+ Pump

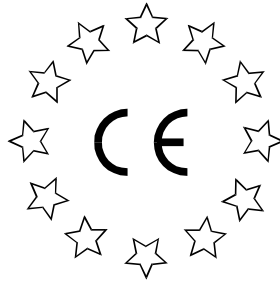





## Declaration of Conformity for Pumps

SPX Flow Technology Rosista GmbH, Zechenstr. 49, D-59425 Unna-Königsborn  
herewith declares that the

**pumps of the series**

**DW1, DW2, DW3, DW4, DW5, DW6, DW7**

**W+ 10/8, W+ 22/20, W+ 30/80, W+ 25/210, W+ 35/35, W+ 35/55,  
W+ 30/120, W+ 50/600, W+ 50/8, W+ 55/35, W+ 55/60, W+ 60/110,  
W+ 65/350, W+ 70/40, W+ 80/80, W+ 110/130, W+ 140/50**

**Wi+, WHP+, Wa+, WK+, Ws+**

**PUMA+ 10, PUMA+ 20, PUMA+ 30**

**PUMAi+ 10, PUMAi+ 20, PUMAi+ 30**

meet the requirements of the Directives 2006/42/EC (superseding 89/392/EEC  
and 98/37/EC) and GPSG - 9.GPSGV.

For official inspections, SPX Flow Technology Rosista GmbH presents  
a technical documentation according to Appendix VII of the Machinery Directive,  
this documentation consisting of documents of the development and construction,  
description of measures taken to meet the conformity and to correspond with  
the basic requirements on safety and health, incl. an analysis of the risks,  
as well as an operating manual with safety instructions.

The conformity of the pumps is guaranteed.

Authorised person for the documentation:  
SPX Flow Technology Rosista GmbH, Frank Baumbach, Zechenstr. 49, D-59425 Unna

November 30, 2010

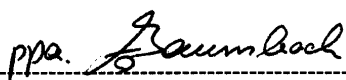
  
-----  
Manager Research and Development



---

## Contents

---

Section	Description	Page
<b>1</b>	<b>General description</b>	<b>2</b>
1.1	Intended use	2
<b>2</b>	<b>Sectional drawing W+ pump</b>	<b>3</b>
	Sectional drawing – shaft seal	3
<b>3</b>	<b>Warnings</b>	<b>4</b>
<b>4</b>	<b>Introduction</b>	<b>5</b>
4.1	The W+ program	5
4.2	The W+ pump, standard and auxiliary equipment	5
4.3	Identification of pump models	5
4.4	Identification of motor models	5
4.5	Handling and Transport	6
4.6	Weights	6
<b>5</b>	<b>Installation of pump</b>	<b>7</b>
5.1	Positioning	7
5.2	Lining up the pipe system	7
5.3	Power supply	7
5.4	Liquid supply for flushed shaft seals	7
5.5	Connection of steam or steam condensate for aseptic applications	7
<b>6</b>	<b>Start-up and Operation</b>	<b>8</b>
6.1	Checking the pump body for foreign material	8
6.2	Checking the pump	9
6.3	Starting the pump	9
6.4	Flushing liquid	9
<b>7</b>	<b>Service and Maintenance</b>	<b>10</b>
7.1	Checking the shaft seal	10
7.2	Replacing the shaft seal	10
7.3	Replacing the motor	12
7.4	Recommended inventory of spare parts	13
<b>8</b>	<b>Technical Data</b>	<b>14</b>
8.1	Sound pressure and sound effect level for W+ pumps	14
8.2	Permissible initial pressure for W+ pumps	15
8.3	Torques	15
8.4	Cleaning recommendation	15

Spare parts, see separate spare parts list

---

## 1. General description

---

**W+**

This operating manual should be read carefully by the competent operating and maintenance personnel.

We point out that we will not accept any liability for damage or malfunctions resulting from the non-compliance with this operating manual.

Descriptions and data given herein are subject to technical changes.

### 1.1 Intended Use

The centrifugal pump W+ is exclusively intended for pumping liquids, especially in beverage and food installations.

Its use is permissible only within the admissible pressure and temperature margins and under consideration of chemical and corrosive influences.

Any use exceeding the margins and specifications set forth is considered to be not intended.

Any damage resulting therefrom is not within the responsibility of the manufacturer.  
The user will bear the full risk.

#### Attention:

Improper use of the pump leads to:

- damage
- leakage
- destruction.
- Failures in the production process are possible.



## 2. Sectional drawing

W+

- 1a pump housing
- 2a cap nut
- 3 o-ring
- 4 impeller
- 6 o-ring
- 7a back plate
- 8 locating pin
- 9a clamp ring
- 10 o-ring
- 11 shaft
- 14 extension frame
  
- 5.1 fastening kit for single mech. seal
- 5.3 pressure ring
- 5.4 drain pipe
- 5.5 o-ring
- 5.6 stationary seal face
- 5.7 rotary seal face
- 5.8 pin
- 5.9 fastening kit double mech. seal
- 5.10 o-ring
- 5.11 pressure ring

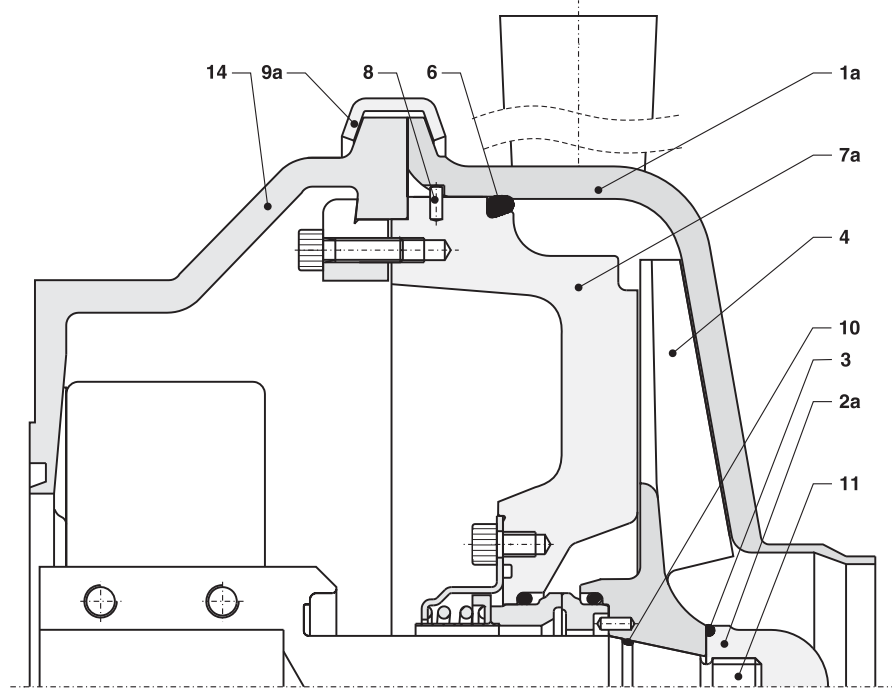

- Section 1: single mechanical shaft seal for shafts Ø25 and Ø35
- Section 2: double mechanical shaft seal for shafts Ø25 and Ø35
- Section 3: single mechanical shaft seal for shafts Ø55
- Section 4: double mechanical shaft seal for shafts Ø55

**Section 1**

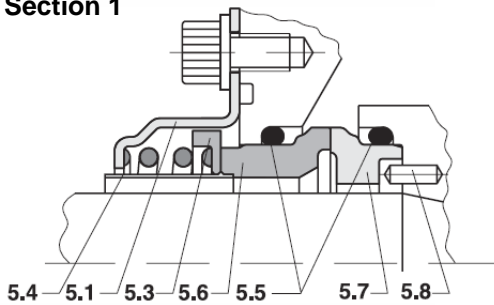

**Section 2**

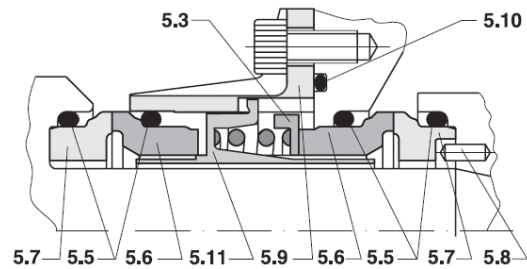

**Section 3**

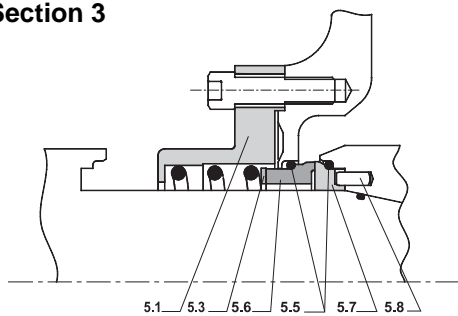

**Section 4**

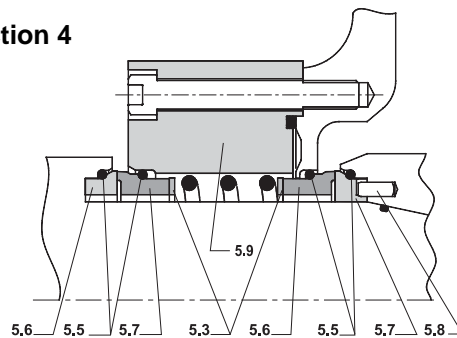

### 3. Warnings

**W+**

1. Read through the instructions before installing the pump and starting it up. If in doubt, contact your local SPX Flow Technology representative.
2. Check that the specifications of the motor and motor control unit are correct. This applies in particular for applications with risk of explosion.
3. Observe that a pump may be unstable and may tilt to the fore onto its inlet port when having a relatively small motor and being assembled on brackets instead of being equipped with a frame with adjustable feet. Be careful during the installation of such a pump. (For this reason, the W+50/600 pump is equipped with an anti-tilting unit.)
4. Do not start the pump before all pipe connections have been fitted carefully and tightened. Special precautions must be taken when the pump is used to pump hot and/or hazardous liquids. In such cases follow the local regulations for personal safety when working with these products.
5. Do not start the pump before the motor shroud or shaft guard has been securely fitted.
6. The pump contains rotating parts. Never put your hands, fingers or objects into a pump while it is in operation.
7. Never touch the shroud during operation, as it can become very hot.
8. Never touch the pump body during operation if the pump is being used for hot media where there is the risk of burning.
9. Never close both the intake and outlet valve of the pump while it is in operation. If the pump runs with liquid in it without circulation, the liquid will heat up and may turn into vapour, causing the risk of explosion.
10. Always remove all assembly and auxiliary tools from the pump before starting it up.
11. Never hose down or clean the electric motor directly with water or cleaning fluid.
12. Never lift the pump at the shroud, as it is not designed to carry the weight of the motor. Remove the shroud before lifting the pump. Always use securely fitted lifting straps when lifting with a crane or similar lifting gear.
13. Never dismantle the pump before the motor has been disconnected from the power supply. Remove the fuses and disconnect the cable from the motor terminal box.
14. All electrical installations must be carried out by qualified personnel.
15. Never dismantle the pump until the pipe system has been drained. Remember that liquid will always collect in the pump body. If the pump is to be used for hot and/or hazardous liquids, special precautions must be taken. In such cases follow the local regulations for personal safety when working with these products.
16. The following values specified for the permissible pressure must not be exceeded:  
 Max. 18bar W+10/8, W+22/20, W+30/80, W+35/55, W+35/35, W+110/130  
 Max. 14bar W+25/210, W+30/120, W+50/600, W+50/8, W+55/35  
 W+55/60, W+60/110, W+65/350, W+70/40, W+80/80

The a.m. values are also valid for corresponding models of the Wa+ and Wi+ ranges. It is important to remember that the values for the maximum outlet pressure apply to water at a temperature of 20 °C.

### 4.1 The W+ range

This manual covers the standard versions of the W+ pump as well as the aseptic versions - Wa+ and pumps with inducer - Wi+. Check the pump's nameplate to ensure that you have one of the above versions. The WHP+ and W+140/50 are described in a separate manual which is supplied with the pump. The WK+ (pedestal pump version) is described in a supplementary manual.

### 4.2 The W+ pump, standard and auxiliary equipment

Standard options:

- with or without jacket
- with frame and feet or firm supports
- with shaft seal in carbon / SiC or SiC / SiC
- with o-rings in EPDM or FPM (Viton)
- with single mechanical or double mechanical seal, prepared for water-flushed or steam-flushed shaft seal (Wa+)

Additional options:

- heating/cooling jacket
- casing drain
- sound absorbing jacket
- pump cart
- inducer (Wi+)
- double o-ring seal of pump housing, prepared for sterile flushing (Wa+)
- Heavy duty clamp ring, increasing the pump's maximum permissible outlet pressure to 25 bar (available for W+30/120, W+55/35, W+55/60, W+60/110, W+70/40) or to 20 bar (available for W+80/80).
- W+ pumps can be supplied with all standard welded ferrules such as unions, clamp rings or flanges.

Fig. 1

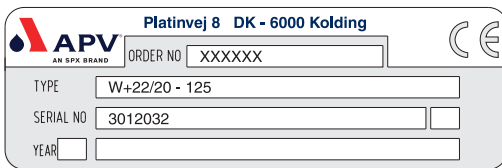

### 4.3 Identification of pump models

A nameplate as shown in Fig. 1 is fitted on the extension frame.

#### Example

- Type W+22/20: Specifies the pump model, here: W+22/20.  
 125: Indicates the diameter of the impeller.  
 Serial No.: Indicates the series number of the pump.  
 Order No.: Specifies the SPX FT order number.  
 Year: Shows the year of manufacture.

The empty field can be used to identify the pump within an installation.

Fig. 2

**ABB Motors**

Motor 3~ Cl.F IP55 IEC34 IM2001 MT100LB28-2F215 NO.1646850						
	V	Hz	Min <sup>-1</sup>	kW	A	Cos φ
2	380-420 Y/220-240D	50	2890	4.0	8.3/14.4	0.87
	380-480 Y/220-280 D	60	3480	4.0	8.0/13.9	0.87

1

### 4.4 Identification of motor models

A nameplate as shown in Fig. 2 is fitted on the motor.

The plate indicates the motor type and height of construction (pos. 2), motor capacity (kW) (pos. 1) and speed, etc.

## 4. Introduction

W+

Fig. 3

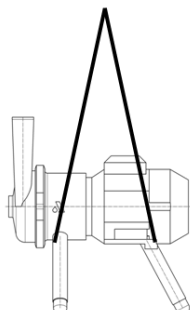

### 4.5 Handling and Transport

Act with caution when lifting the pump. All parts with a weight of more than 20 kg must be handled with a suitable hoisting device.

Use a crane, fork-lift truck or another suitable hoisting device, always together with 2 lifting ropes (Fig. 3).

Place the hoisting belts around the rear part of the motor and around the extension frame. Take care that the belts are evenly loaded when the pump is lifted.

**Attention:**

Always use 2 hoisting belts and never fasten them at the front pump body.

### 4.6 Weights

Pumpentyp Pump type	Motor											
	80	90	100	112	132	160	180	200	225	250	280	
	0,75 kW 1,1 kW	1,5 kW 2,2 kW	3,0 kW	4,0 kW	5,5 kW 7,5 kW	11,0 kW 15,0 kW 18,5 kW	22,0 kW	30,0 kW 37,0 kW	45,0 kW	55,0 kW	75,0 kW 90,0 kW	
W+10/8	20 20	----	----	----	----	----	----	----	----	----	----	----
W+22/20	28 29	33 36	41	46	57 62	----	----	----	----	----	----	----
W+30/80	----	53 56	61	66	77 82	117 127 138	----	----	----	----	----	----
W+25/210*	----	----	----	----	----	169 184 194	212	282 295	349	----	----	----
W+35/35	----	36 39	44	49	60 65	100 109 117	----	----	----	----	----	----
W+35/55	----	51 51	59	64	75 80	114 123 133	----	----	----	----	----	----
W+30/120	----	59 62	67	71	83 88	125 135 145	170	236 249	----	----	----	----
W+50/600	----	----	----	----	----	----	295	360 381	426	485	570 605	----
W+50/8	----	45 48	53	58	69 73	----	----	----	----	----	----	----
W+55/35	----	54 59	66	71	82 87	127 136 147	----	----	----	----	----	----
W+55/60	----	61 64	71	76	88 93	127 136 146	171	226 251	----	----	----	----
W+60/110	----	68 71	76	82	94 99	132 141 151	176	225 250	295	----	----	----
W+65/350	----	----	----	----	132 137	171 180 190	220	295 330	363	420	505 540	----
W+70/40	----	75 78	83	87	99 104	138 148 158	183	238 263	----	----	----	----
W+80/80	----	83 83	89	95	107 112	146 155 165	190	265 280	335	395	----	----
W+110/130	----	----	105	109	118 123	160 173 183	218	276 300	355	415	500 535	----

\* nur 1500 Upm / only 1500 rpm

The weights indicated above are for standard pumps with motor shrouds. The weights can vary depending on accessories and fittings and shall be considered as reference value for handling, transport and packaging, only.

### 5.1 Positioning

The following aspects have to be observed:  
 The pump must be positioned so that the suction pipe is as short as possible and there is a sloping gradient towards the suction port of the pump.  
 Keep the number of valves, bends and tee-pieces on the suction side to an absolute minimum.  
 There must be sufficient space around the pump for piping and access for maintenance.

### 5.2 Lining up the pipe system

Line up the pipes carefully to the suction and discharge ports of the pump. Make sure that the pipe system is adequately supported by pipe supports so that the pump body is not subject to strains and weight from the pipe system.

**Note:** During the suction process, the pump may tend to vibrate. A pipe support should be placed close to the pump suction to prevent pipework vibration creating excessive noise.

### 5.3 Power supply

The motor must be connected via a control cabinet to the network in compliance with the local regulations. Moreover, the motor must be connected in accordance with the instructions indicated in the inner side of the connecting box lid of the motor. The motor should be connected such that the rotating direction of the motor and thus the impeller is counter-clockwise when viewed from the front towards the suction port of the pump body. Fig. 4.

Fig. 4

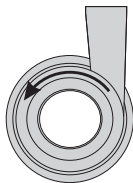

### 5.4 Liquid supply for flushed shaft seal

Pumps with flushed shaft seal have two PTFE hose connectors on the seal flange. The hose connectors are 1/8 inch and fit 6.0 mm hoses. The required flow quantity amounts to 15 - 30 l/h. The maximum permissible pressure is 7 bar.

The hose connection should always be positioned vertically with the fluid inlet below and the outlet above. Fig. 5.  
 Fluid consumption can be limited by installing a solenoid valve on the supply side. The open/close function of the solenoid valve can be controlled by the pump's start/stop sequence.  
 Do not use steam or steam condensate at the connection for flushing liquids. If you want to use steam as sealing medium, a special aseptic pipe connector must be used. Connectors see 5.5.

Fig. 5

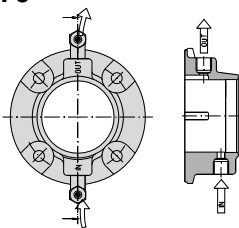

### 5.5 Connecting steam and steam condensate for aseptic use

When static double seals are used, the connection for steam or steam condensate at the pump body is provided with fittings for 8 mm stainless steel pipes.  
 Steam with up to 150 °C and 5 bar can be used.

## 6. Start-up and Operation

W+

Before starting the pump, dismantle and clean the suction pipe. Any foreign material in the pump should be removed.

### 6.1 Checking the pump for foreign material

Remove the pump body as described below. The sectional drawing (page 3) is to be used for reference.

1. Disconnect the power supply.
2. Remove the pump body (items 1a, 1b) by undoing the clamp ring (pos. 9a) or body screws and carefully pull off the pump body.
3. Turn the impeller (item 4) to ensure that there is no foreign material behind it.
4. If there is any foreign material in the pump, remove it.
5. When the pump body is clean and free of foreign material, reassemble the pump.

Mount the pump body as described below:

6. Check that the locating pin (item 8), where fitted, in the top of the back plate, mates with the detent in the pump body and carefully (to avoid damage to the o-ring) press the pump body (item 1a, 1b) in over the o-ring (item 6) and fasten with the clamp ring (item 9a) or body screws, observing the correct tightening torque.

M8: 30 Nm ( 22 ft-lb)

M10: 55 Nm ( 41 ft-lb)

M16: 180 Nm (132 ft-lb)

7. Install suction and discharge pipes. Check that the pipe unions have been tightened properly and that pipe supports have been fitted.

To make the front cover and the pump housing easier to fit, we recommend to provide the o-ring with a thin layer of food-approved, acid-free grease or soap.



## 6. Start-up and Operation

W+

Fig. 6

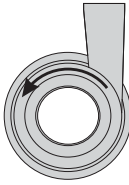

### 6.2 Checking the pump

To check that the pump is working satisfactorily, pour water into the pump and start it for a moment. Check the direction of rotation. Fig. 6. Listen for any unusual noises. In pumps with water-flushed or steam-flushed shaft seals, the seal chamber must be filled with water/steam.

Never allow the pump to run without liquid, as this will ruin the shaft seal.

### 6.3 Starting the pump

Check the following before starting the pump:

- that the shaft guard has been fitted properly.
- that there is free access for liquid and the pump is primed.
- that the valve on the discharge side is closed.

The valve on the discharge side is closed during start-up to prevent the motor from overloading, but should be opened again as soon as the pump has been started.

**Note!**

The pump should not be left running too long without pumping (typically 15 minutes, if the pumped liquid is not hot), as it gets warm and loses priming liquid by evaporation.



### 6.4 Flushing liquid

In pumps with flushed shaft seal, check that the supply of flushing medium is open and that the flow of the medium is adequate (about 15 - 30 litre / hour).

## 7. Service and Maintenance

**W+**

### 7.1 Checking the shaft seal

Check the pump's shaft seal for leaks on a regular basis. If the shaft seal is leaking, replace it or its relevant parts as described below.

### 7.2 Replacing the shaft seal

The sectional drawing (page 3) shows the position and construction of the shaft seal – both ordinary seals and seals with liquid / steam flushing.

To replace the shaft seal it is necessary to dismantle the pump. Follow the steps described below and refer to the sectional drawing (page 3).

1. Disconnect the power supply in the motor isolator by removing the fuses and disconnecting the cables.
2. Turn off the steam and flushing liquid supply.
3. Close the suction and discharge of the pump and drain the pump housing. If the pump is used for hot and/or aggressive liquids, special precautions must be taken. In such cases, observe the local regulations for personal protection when working with these products.
4. Open the clamp ring (item 9a) or the housing screws, once the inlet and outlet pipes have been properly isolated. Dismantle the pump housing (item 1a, 1b) and remove the impeller (item 4).
5. Take the stationary seal face (item 5.6) installed in the back plate (item 7a, 7b) out with your fingers.
6. Remove the o-ring (item 5.5) from the stationary seal face.
7. Take the rotary seal face (item 5.7) installed in the impeller (item 4) out with your fingers.
8. Remove the o-ring (item 5.5) from the rotary seal face.
9. Clean the chambers of the stationary and rotary seal face with air or water.
- 9a In the case of water-flushed shaft seals and aseptic shaft seals, dismantle the back plate for the disassembly of the rear shaft seal. The rear stationary seal face (item 5.6) is mounted to the pressure ring \*(item 5.11). The rotary seal face (item 5.7) is mounted to the shaft (item 11). These are removed in the same way as the front seal components.  
\*The W+50/600 pump has 2 identical pressure rings.

#### Dismantling the pump



#### Dismantling the shaft seal

## 7. Service and Maintenance

**W+**

### Checking parts for wear



### Fitting

10. Check the o-rings for signs of stiffness, lack of elasticity, brittleness and/or chemical attack. Replace worn or damaged parts.
11. Check the stationary ring (item 5.6) and rotary ring (item 5.7) for signs of wear. Wear surfaces must be completely free of cracks. If this is not the case, both – the stationary ring and the rotary ring - must be replaced.
- 11a In the case of water-flushed shaft seals and aseptic shaft seals, check the rear seal rings (item 5.6, 5.7) for wear, and replace if necessary.
12. Fit the new o-rings on the stationary seal face and rotary seal face.  
**Note!** Remember to moisten these with water.
13. Fit the rotary seal face on the impeller without using tools.  
**Note!**  
The notch in the rotary seal face must be fitted so that it mates with the driving pin (item 5.8) in the impeller hub.
- 13a In the case of double mechanical shaft seals, also fit a rotary seal face (item 5.7) with o-ring (item 5.5) in the location on the shaft – again without using tools.
14. Fit the stationary seal face in the back plate without using tools.  
**Note!**  
Fix the stationary seal face so that it fits to the pin in the back plate. Check that the stationary seal face is positioned so that it slides back and forth easily within the back plate.
- 14a When fitting new double mechanical shaft seals, remove the drain pipe (item 5.4) before fitting them in the pressure ring (item item 5.9) or back plate (item 7a, 7b).  
\* The W+50/600 pump is not equipped with a drain pipe.
15. After fitting, clean the wearing surfaces.
- 15a For double mechanical shaft seals, re-mount the back plate (item 7a,7b).
18. Fit the impeller (item 4). Remember to use the proper tightening torque.  
M10: 45 Nm (33 ft-lb)  
M14: 70 Nm (52 ft-lb)  
M20: 200 Nm (148 ft-lb)
17. Check that the locating pin (item 8) in the top of the back plate, mates with the detent in the pump body. To avoid damaging the o-ring, carefully press the pump body (item 1a, 1b) in over the o-ring (item 6) and fasten the clamp ring (item 9).  
Remember to use the proper tightening torque:  
M8: 30 Nm (22 ft-lb)  
M10: 55 Nm (41 ft-lb)  
M16: 180 Nm (132 ft-lb)

### 7.3 Replacing the motor

The standard motor of the W+ pump has a locked front bearing. If the motor is replaced, the new motor must also have a locked front bearing. The motor bearing is enclosed and permanently lubricated.

The motor is equipped with feet and flanges: „small flange“ (B34) for frame sizes 80-132, "large flange" (B35) for frame size 160 and larger.

When replacing the motor, follow the instructions below. For the replacement of bearings, see the motor supplier's service instructions.

1. Lock Out power supply, then disconnect the pump and motor from system.
2. Remove the pump body. See 7.2, paragraph 1-4.
3. Dismantle the impeller.
4. Remove the motor shroud and, if possible, place the pump vertically on the motor's fan cover. Fig. 7.
5. Release the four motor flange screws and remove them. Fig.7.
6. Lift the back plate (item 7) and extension frame which are still bolted together, up and off the shaft. See Fig. 7. Remove the spacer flange (item 17) (where fitted).
7. See Fig. 8. Loosen the screws in the base of shaft, pull the shaft off and replace the motor.
8. See Fig. 9. Before mounting the new pump shaft, remove any dirt and grease from the motor shaft and the base's internal clamping surfaces. Mount the pumps shaft loosely. Position the balance hole over the keyway.
9. Fit the back plate and extension frame over the shaft.
10. Tighten the bolts.
11. Stand the pump back on its legs/brackets.
12. Fit the impeller and secure it with the cap nut / inducer.

Fig. 7

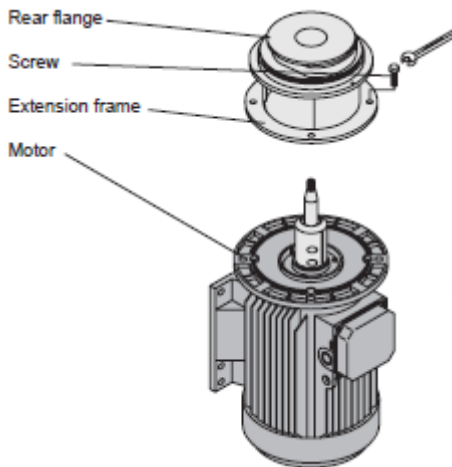

Fig. 8

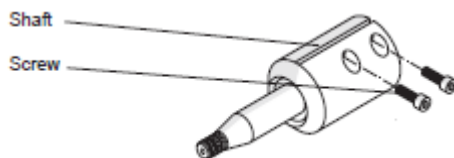
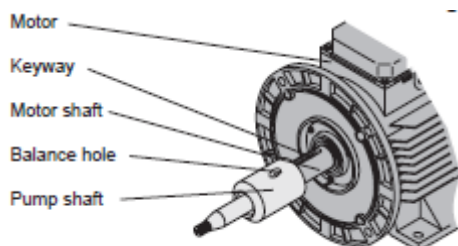

Fig. 9



Remember to use the proper tightening torque:

M10: 45Nm ( 33 ft-lb)

M14: 70Nm ( 52 ft-lb)

M20: 200Nm (148 ft-lb)

## 7. Service and Maintenance

W+

Fig. 10

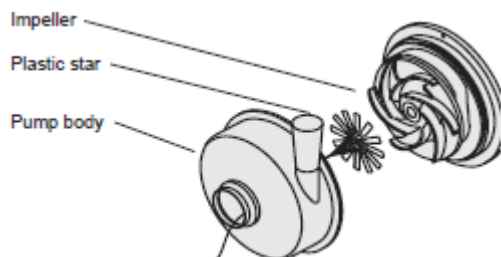
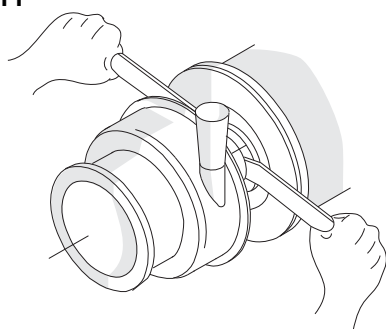

Fig. 11



13. Place the plastic star against the impeller. Fig. 10.
14. Fit the pump/screw housing and fasten with the clamp ring.
15. Push the shaft forward until the impeller is touching the plastic star. See Fig. 11.
16. Tighten the shaft screws (item 11).  
Remember to use the proper tightening torque:  
M8: 30 Nm ( 22 ft-lb)  
M10: 55 Nm ( 41 ft-lb)  
M12: 80 Nm ( 59 ft-lb)  
M16: 180 Nm (132 ft-lb)
17. Remove the star by pulling it out through the inlet.

### 7.4 Recommended inventory of spare parts

#### Seal kits

We recommend that you keep both seal kits and service kits for the W+ pumps in stock. The seal kit for the W+ pump consists of the wearing parts of the pump, as specified in the spare parts list.

	Number of pumps in service		
	0-5	5-20	>20
Seal kits	sets	sets	sets / 10 pumps
Normal operation	2	3	1
Special needs	3	6	2

#### Service kit

The service kit is made up of a number of the main components of the pump which are not wearing parts, but which you still may have to replace: shaft, impeller, cap nut and fixing kit.

	Number of pumps in service		
	0-5	5-20	>20
Service kits	sets	sets	sets / 10 pumps
Normal operation	0	1	1
Special needs	1	2	1

## 8. Technical Data

## W+

### 8.1 Sound pressure and sound effect level

Measurements have been carried out in accordance with ISO 3743, Grade 2 and ISO 3746, Grade 3. Tolerance:  $\pm 3$  dB.

LpA in dB refers to the sound pressure level at a distance of one meter from the surface of the pump at a height of 1.6 m above floor level (cf. EC Directive (89/392/EEC)).

Lwa states the sound power level.

Operating conditions A, B and C are defined as follows:

- A. Nominal flow and max. permissible operating pressure
- B. Nominal flow and 60% operating pressure
- C. 60% flow and max. permissible operating pressure

The nominal flow and max. permissible operating pressure in the case of the W+ 55/60, for example, are 60m<sup>3</sup>/hr at an operating pressure of 5.5 bar, and so on.

This information only applies if the motor used is an ABB aluminium motor and the size of the motor matches the power requirement of the pump.

The noise level may increase considerably, if reducers (reduction/expanding fittings) are mounted at the inlet/outlet.

The values shown apply when the pumps run at 2900 rpm and have a shroud over the motor. If the pumps are run at 1450 rpm, the values are reduced by about 20 dB. The values for the W+ 25/210 apply at 1450 rpm.

Operating conditions	LpA			LwA		
	A	B	C	A	B	C
W+10/8	65	62	60	79	77	74
W+22/20	67	65	61	81	79	75
W+30/80	75	73	68	89	87	82
W+25/210	69	68	64	83	82	78
W+35/35	69	67	64	83	81	78
W+35/55	72	70	67	86	84	81
W+30/120	76	74	72	90	88	86
W+50/8	69	68	64	83	82	78
W+50/600	75	75	73	89	89	87
W+55/35	69	68	68	83	82	82
W+55/60	74	70	68	88	84	82
W+60/110	76	74	72	87	85	84
W+65/350	86	88	82	100	102	98
W+70/40	75	69	69	89	83	83
W+80/80	75	73	72	89	87	86
W+110/130	79	76	76	93	90	90

Please observe that the sound emitted by a pump varies a lot. It depends on the pump design (size / speed / shroud / installation) as well as on the liquid type and pumping conditions.

### 8.2 Maximum permissible outlet pressure for W+ pumps

The maximum pump outlet pressure specified below must not be exceeded (applies to water at 20°C).

**Max. 18 bar:** W+10/8, W+22/20, W+30/80, W+35/55, W+35/35, W+110/130

**Max. 14 bar:** W+25/210, W+30/120, W+50/600, W+50/8, W+55/35, W+55/60, W+60/110, W+65/350, W+70/40, W+80/80

The above values also apply for the corresponding models of the Wa+ and Wi+ design.

### 8.3 Tightening torques

Required torques to tighten the pump shaft on the motor shaft:

M8: 30 Nm ( 22 ft-lb)  
 M10: 55 Nm ( 41 ft-lb)  
 M12: 80 Nm ( 59 ft-lb)  
 M16: 180 Nm (132 ft-lb)

**Note:**

Make sure that the key-groove of the motor shaft is to be seen through the hole in the stub shaft. Fig. 12.

Required torque to tighten the cap nut and the inducer:

M10: 45 Nm ( 33 ft-lb)  
 M14: 70 Nm ( 52 ft-lb)  
 M20: 200 Nm (148 ft-lb)

Required torque to tighten the clamp connection at the pump body and body cover:

M8: 30 Nm ( 22 ft-lb)  
 M10: 55 Nm ( 41 ft-lb)  
 M16: 180 Nm (132 ft-lb)

### 8.4 Cleaning recommendation

The product-wetted parts of the pumps are cleaned by the cleaning liquid of the connected pipelines.

Depending on the degree and constituents of soiling, cleaning liquids, times and cycles must be adjusted for the individual application.

Verify the compatibility of the individually selected cleaning processes and liquids with the respectively used seal materials.

**Subject to change.**



Fig. 12

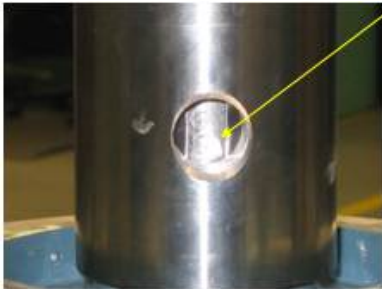

Original operating manual



Your local contact:



SPX Flow Technology  
Grunwaldzka 229  
85451 Bydgoszcz, Poland  
Phone: +48 525 259 900 Fax: +48 525 810 085

For more information about our worldwide locations, approvals, certifications and local representatives, please visit [www.spxft.com](http://www.spxft.com)

SPX Corporation reserves the right to incorporate our latest design and material changes without notice or obligation. Design features, materials of construction and dimensional data, as described in this bulletin, are provided for your information only and should not be relied upon unless confirmed in writing. Certified drawings are available upon request.

Copyright © 2008 SPX Corporation