



# Instruction Manual PUMA+ Pump



Read and understand this manual prior to operating or servicing this product.





## Contents:

UK

Section	Page	Description
-	16	<b>Sectional Drawing</b>
0	19	<b>Warnings</b>
1	20	<b>Introduction to the W+ programme</b>
1.1	-	W+ range
1.2	-	W+ pump, options and extras
1.3	-	Identifying the pump model
1.4	-	Identifying the motor model
2	21	<b>Installation of the pump</b>
2.1	-	Positioning
2.2	-	Lining up the pipesystem
2.3	-	Power supply
2.4	-	Water supply for water-flushed shaft seal
2.5	-	Connecting steam or steam condensate supply for aseptic use
3	22	<b>Before start-up</b>
3.1	-	Checking the pump body for foreign material
3.2	-	Testing the pump
4	22	<b>Putting the pump into service</b>
4.1	-	Flushing water/steam/condensate etc.
5	23	<b>Maintenance</b>
5.1	-	Checking the shaft seal
5.2	-	Replacing the shaft seal
5.3	25	Replacement of motor
5.4	26	Recommended stocks of spare parts
6	27	<b>Technical data</b>
6.1	-	Sound pressure and sound effect level for W+ Pumps
6.2	-	Maximum permissible output pressure for W+ Pumps
6.3	-	Tightening torque for impeller, inducers and shaft
7	30	<b>Pump dimensions</b>
7	37	<b>Spare parts list</b>
-	-	Pump complete
-	38	Pump housing
-	41	Inducer housing
-	42	Impeller
-	43	Shaft seal
-	45	Complete seal kit, single
-	46	Complete seal kit, double
-	47	O-rings kit
-	48	Shaft
-	49	Extension frame and shaft guard
-	51	Frame, motor 80 - 132
-	52	Frame, motor 160
-	53	Frame, motor 180
-	54	Bracket, motor 80 - 200
-	55	Collar and shroud

**Sectional Drawing**

**PUMA+**

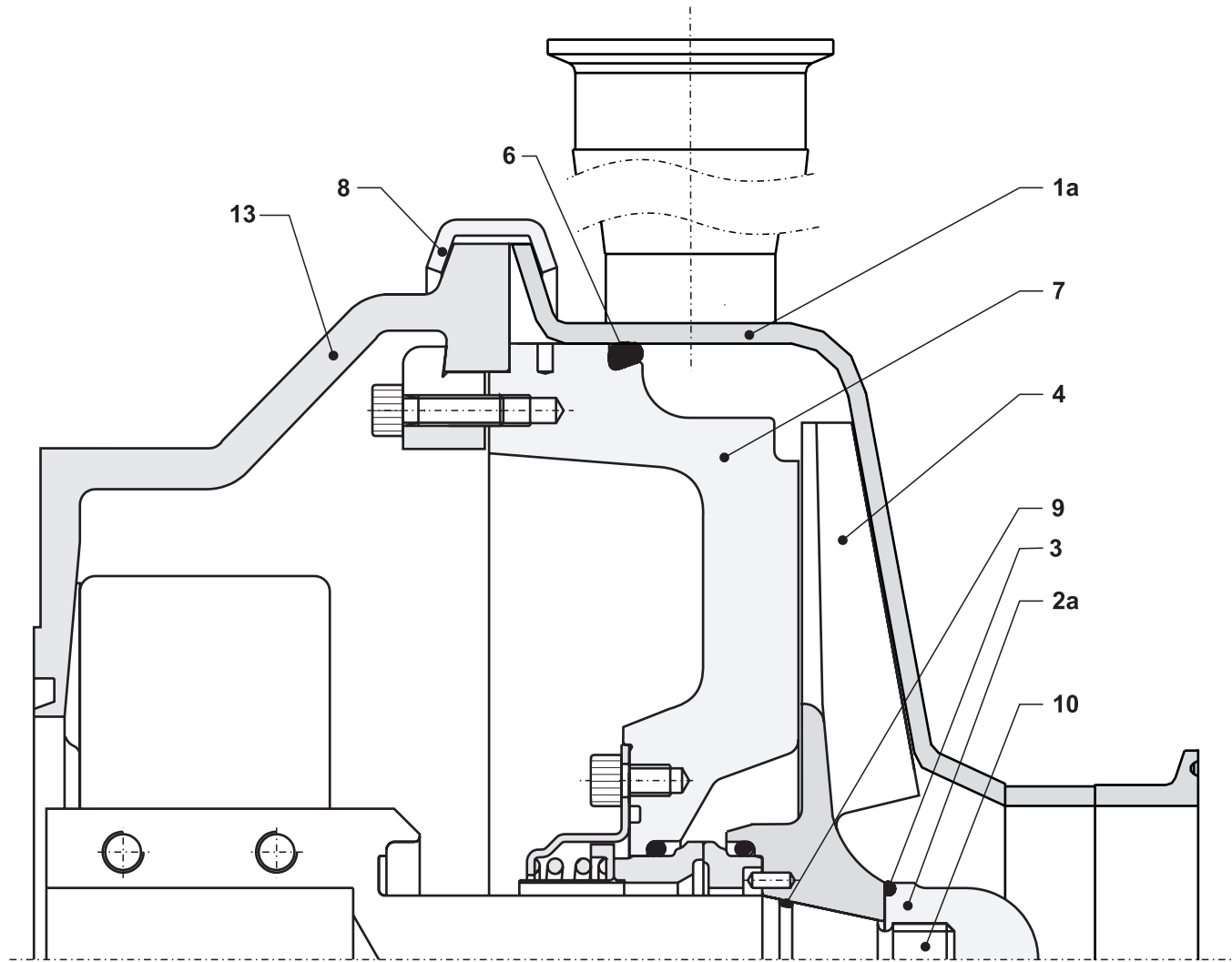

**Section 1**

Shaft size  $\varnothing 25$  and  $\varnothing 35$

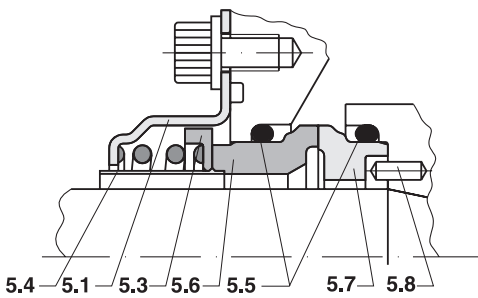

**Section 2**

Shaft size  $\varnothing 25$  and  $\varnothing 35$

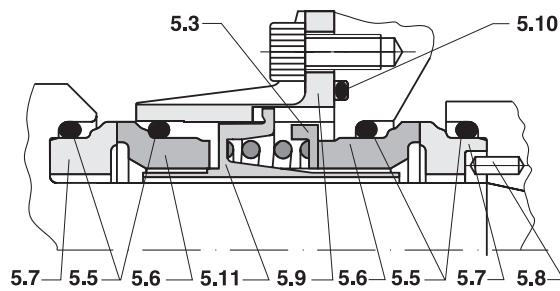

## Sectional Drawing

**PUMA+**

<b>1a:</b>	Pump housing
<b>2a:</b>	Cap nut
<b>3:</b>	O-ring
<b>4:</b>	Impeller
<b>6:</b>	O-ring
<b>7:</b>	Back plate
<b>8:</b>	Clamp ring
<b>9:</b>	O-ring
<b>10:</b>	Shaft
<b>13:</b>	Extension frame

**Section 1** Single seal for shaft size  $\varnothing 25$  and  $\varnothing 35$

**Section 2** Double seal with liquid/steam flushing for shaft size  $\varnothing 25$  and  $\varnothing 35$

<b>5.1:</b>	Seal housing
<b>5.3:</b>	Pressure ring
<b>5.4:</b>	Drain pipe
<b>5.5:</b>	O-rings
<b>5.6:</b>	Stationary seal face
<b>5.7:</b>	Rotary seal face
<b>5.8:</b>	Pin
<b>5.9:</b>	Seal housing
<b>5.10:</b>	O-ring
<b>5.11:</b>	Pressure ring



## 0. Warnings



1. Read through the instructions before installing the pump and starting it up. If in doubt, contact your local APV dealer.
2. Check that the specifications of the motor and motor control unit are correct, particularly in operating environments where there may be a risk of explosion.
3. Be aware that a pump, if supplied mounted on a relatively small motor and on brackets rather than a frame with adjustable feet, may be unstable and can tip forward on its inlet nozzle. Take care when handling such a pump prior to installation.
4. Do not start the pump before all the pipe connections have been fitted carefully and tightened. If the pump is to be used for hot and/or hazardous liquids, special precautions must be taken. In such cases follow the local regulations for personal safety when working with these products.
5. Do not start the pump before the motor shroud or shaft guard has been securely fitted. The pump contains rotating parts. Never put your hands or fingers into a pump while it is in operation.
6. Never touch the shroud during operation, as it can become very hot.
7. Never touch the pump body during operation if the pump is being used for hot media where there is a risk of burning.
8. Never close both the intake and outlet of the pump while it is in operation. If the pump runs with liquid in it without circulation, the liquid will heat up and may turn into vapour, causing a risk of explosion.
9. Always remove all assembly tools from the pump before starting it up.
10. Never hose down the electric motor directly with water or cleaning fluid.
11. Never lift the pump in the shroud, as it is not designed to carry the weight of the motor. Remove the shroud before lifting the pump. Always use securely fitted lifting straps when lifting with a crane or similar lifting gear.
12. Never dismantle the pump before the motor has been disconnected from the power supply. Remove the fuses and disconnect the cable from the motor terminal box.
13. All electrical installation must be carried out by qualified staff.
14. Never dismantle the pump until the pipe system has been drained. Remember that liquid will always collect in the pump body. If the pump is to be used for hot and/or hazardous liquids, special precautions must be taken. In such cases follow the local regulations for personal safety when working with these products.
15. The maximum pump outlet pressures specified below must not be exceeded:

**Max. 16 bar:** PUMA+10, PUMA+20, PUMA+30

The above values also apply to the corresponding models in the PUMAi+ versions. It is also important to remember that the values for maximum outlet pressure apply to water at a temperature of 20°C.

# 1. Introduction to the PUMA+ programme

## 1.1 The PUMA+ range

This manual covers all the standard versions of the PUMA+ pump and pumps with inducer (PUMAI+ pumps). Check the pump's nameplate to make sure that you have one of the above versions.

## 1.2 The PUMA+ pump, options and extras

The following standard options are available in the PUMA+ range:

- with or without shroud
- with frame and adjustable feet or fixed bracket
- with shaft seal in carbon/SiC or SiC/SiC
- with O-rings in EPDM or FPM (Viton)
- with single-acting shaft seal or double-action shaft seal prepared for water-flushed or steam-flushed shaft seal

Extras:

- inducer (PUMAI+)
- PUMA+ pumps can be supplied with:
  - DIN 11851 Welding Male Part
  - ISO 2852 Clamp Connection
  - BS 4825 Clamp Connection
  - DIN 32676 Clamp Connection
  - APV FN1 PN10 Flange
  - APV FG1 PN10 Flange

## 1.3 Identifying the pump model

A nameplate as shown in Fig. 1 is fitted on the extension frame.

**Example:**

Type: PUMA+20/50/40/4,0/3000 - Ø230

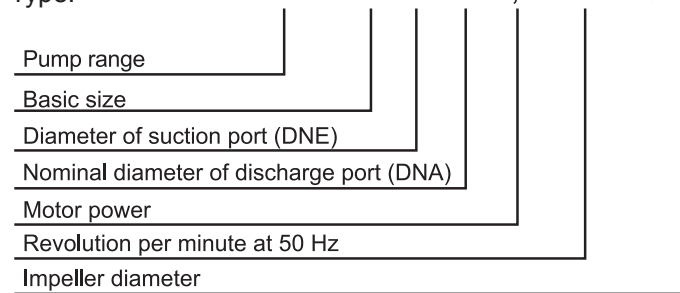
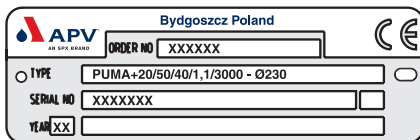

Fig. 1



Serial No.: The "unique" serial number of the pump.  
 Order No.: APV's order number of the pump.  
 Year: Indicates the year of manufacture.

The vacant field can be used to identify the pump in terms of its position in the plant.

## 1.4 Identifying the motor model

The motor is identified by removing the shroud and reading the kW rating and the centreline height of the motor on the type plate.

## 2. Installation of the pump

### 2.1 Positioning

The pump must be positioned so that the suction pipe is as short as possible and there is a falling gradient towards the suction nozzle. Keep the number of valves, bends and tee-pieces on the suction side to an absolute minimum. There must be sufficient space around the pump for piping and access for maintenance.

### 2.2 Lining up the pipe system

Line up the pipes carefully to the pump suction and discharge nozzles. Make sure that the pipe system is adequately supported by pipe supports, so that the pump body is not subject to strains and weight from the pipe system.

### 2.3 Power supply

The motor should be connected to the mains via a motor isolator in accordance with local regulations. The motor should be connected in accordance with the instructions inside the cover of the motor's terminal box.

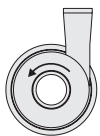

Fig. 2

The motor should be connected such that the direction of rotation of the motor (and thus of the impeller) is anticlockwise when viewed from the front towards the suction nozzle of the pump body (fig. 2).

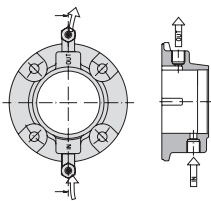

Fig. 3

### 2.4 Water supply for water-flushed shaft seal

Pumps with a water-flushed shaft seal have two hose connectors on the seal flange (fig. 3). The hose connectors are 1/8" and fit a Ø6.0 mm hose. The necessary liquid flow rate is 15 - 30 l/h. Max. pressure 7 bar.

The hose connection in the seal flange should always be positioned vertically with the fluid inlet underneath and the outlet on top.



Water consumption can be limited by installing a solenoid valve for the flushing water on the supply side. The open/close function of the solenoid valve can be controlled by the pump's start/stop sequence.



Do not use the flushing water connectors for steam or steam condensate.

### 3. Before start-up

Before starting the pump, dismantle and clean the suction pipe. Any foreign material in the pump should be removed.

#### 3.1 Checking the pump body for foreign material

Remove the pump body as described below. The assembly drawing is to be used for reference (page 2).

1. Disconnect the power supply.
2. Empty the plant of product.
3. Remove the pump body (item 1a,1b) by undoing the clamp ring (item 8) or body screws and carefully pull off the pump body
4. Turn the impeller (item 4) to ensure that there is no foreign material behind it.
5. If there is any foreign material in the pump, remove it.
6. When the pump body is clean and free of foreign material, reassemble the pump.

Mount the pump body as described below:

7. Check that the mark in the top of the back plate mates with the mark in the pump body and carefully, to avoid damaging the O-ring, press the pump body (item 1a,1b) in over the O-ring (item 6) and fasten with the clamp ring (item 8).
8. Install suction and discharge pipes. Check that the pipe unions have been tightened properly and that pipe supports have been fitted.

To make the pump body easier to fit, we recommend that you give the O-ring a thin layer of food-approved, acid-free grease or soap.



#### 3.2 Testing the pump

To check that the pump is working satisfactorily, pour water into the pump and start it for a moment. Check the direction of rotation (fig. 2). Listen for any unusual noises.

In pumps with water-flushed or steam-flushed shaft seals, the seal chamber must be filled with water/steam.

Never allow the pump to run without liquid, as this will ruin the shaft seal.

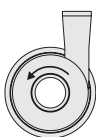

Fig. 2



### 4. Putting the pump into service

Check the following before starting the pump:

- that the shaft guard has been fitted properly
- that there is free access for liquid
- that the valve on the discharge side is closed

The valve on the discharge side (if fitted) is closed during start-up to reduce motor starting current, but should be opened again as soon as the pump has been started.

#### 4.1 Flushing water

In pumps with a flushed shaft seal, check that the supply of flushing medium is open and that the flow of the medium is adequate (approx. 15-30 l/hour).

## 5. Maintenance

### 5.1 Checking the shaft seal

Check the pump's shaft seal for leaks on a regular basis. If the shaft seal is leaking, replace it or its relevant parts as described below.

### 5.2 Replacing the shaft seal

The assembly drawing shows the position and construction of the shaft seal - both ordinary seals and seals with water/steam flushing.

To replace the shaft seal, it is necessary to dismantle the pump as described below. The assembly drawing is to be used for reference.

#### Dismantling the pump

1. Disconnect the power supply in the motor isolator by removing the fuses and disconnecting the cables.

2. Turn off the steam and flushing water supply.

3. Close the inlet and discharge of the pump and drain the pump body.

If the pump is used for hot and/or aggressive liquids, special precautions must be taken. In such cases, observe the local regulations for personal protection when working with these products.

4. Once the inlet and outlet pipes have been closed properly, release the clamp ring (item 8) or body screws, take off the pump body (item 1a,1b) and remove the impeller (item 4).

5. Remove the stationary seal face (item 5.6) mounted in the back plate (item 7) with your fingers.

6. Remove the O-ring (item 5.5) from the stationary seal face.

7. Use your fingers to remove the rotary seal face (item 5.7) mounted in the impeller (item 4).

8. Remove the O-ring (item 5.5) from the rotary seal face.

9. Clean the stator and rotary seal face locations, if necessary with air or water.

9a. In the case of water-flushed/aseptic shaft seals, the back plate must be removed to dismantle the rear shaft seal. The rear seal stationary seal face (item 5.6) is mounted in the pressure ring (item 5.11) and the rotary seal face (item 5.7) is mounted on the shaft (item 10). These are removed in the same way as the front seal components.

10. Check O-rings (item 5.5) for signs of cracks, lack of elasticity, brittleness and/or chemical attack. Replace worn or defective parts.

11. Check the stationary seal face (item 5.6) and rotary seal face (item 5.7) for signs of wear too. The wearing surfaces must be completely free of scratches/cracks. If not, the rotary seal face and stationary seal face must both be replaced.



#### Dismantling the shaft seal

#### Checking wearing parts



## 5. Maintenance

- 11a. In the case of water-flushed shaft seals, check the rear seal rings (item 5.7, 5.6) for wear too, and replace if necessary.
- 12. Fit new O-rings on the stationary seal face and rotary seal face.  
**NB!** Remember to moisten these with water.
- 13. Fit the rotary seal face (item 5.7) on the impeller without using tools.  
**NB!** The "notch" in the rotary seal face must be located so that it mates with the driving pin (item 5.8) in the impeller hub.

### Fitting

- 13a. In the case of water-flushed, also fit a rotary seal face (item 5.7) with its O-ring (item 5.5) in the location on the shaft, again without using tools.
- 14. Fit the stationary seal face (item 5.6) in the back plate without using tools.  
**NB!** The "notches" in the stationary seal face must mate with the driving dogs on the carrier in the back plate. Check that the stationary seal face is positioned so that it slides backwards and forwards easily in the back plate.

### Positioning the water supply connections

- 14a. In the case of water-flushed, remove the drainage baffle (item 5.4) from the stationary seal faces for both the front and rear seal before fitting them in the seal cover (item 5.9) and back plate (item 7) respectively.
- 15. After fitting, clean the wearing surfaces.
- 15a. For liquid-flushed seals, remount the back plate (item 7).
- 16. Fit the impeller (item 4). Remember to use the proper tightening torque:
 

M10:	45 Nm	(33 lbf ft)
M14:	70 Nm	(52 lbf ft)
M20:	200 Nm	(148 lbf ft)
- 17. Check that the mark in the top of the back plate mates with the mark in the pump body and carefully, to avoid damaging the O-ring, press the pump body (item 1a,1b) in over the O-ring (item 6) and fasten with the clamp ring (item 8) or body screws, observing the correct tightening torque.

M8:	30 Nm	(22 lbf ft)
M10:	55 Nm	(41 lbf ft)
M16:	180 Nm	(132 lbf ft)

## 5. Maintenance

### 5.3 Replacement of motor

The standard motor for the PUMA+ pump has a drive-end located bearing. If the motor is replaced, the new motor must also have a drive-end located bearing. The motor bearing is enclosed and permanently lubricated, motor frames 80 - 180.

The motor has both feet and flange, "small flange" (B34) for frame sizes 80-132, "large flange" (B35) for frame 160 and larger.

Follow the instructions below when replacing the motor. For replacement of bearings, see the motor supplier's service instructions.

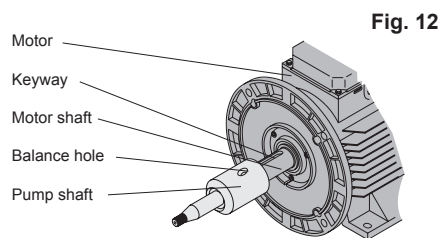
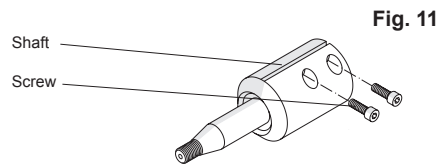
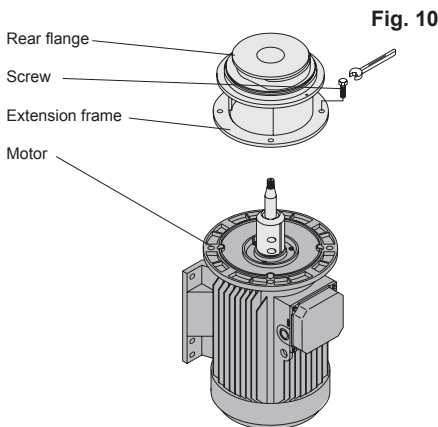

1. Disconnect the pump from the power supply.
2. Empty the plant of product.
3. Removal of the pump body. See para 5.2, points 1-4.
4. Remove the impeller.
5. Remove the motor shroud and, if possible, stand the pump on the motor's fan cover. See Fig. 10.
6. Undo the four motor flange bolts between the motor and extension frame and remove them. See Fig. 10.
7. Lift the back plate, extension frame and spacer flange (where fitted), which are still bolted together, up and off the shaft. See Fig. 10.
8. See Fig. 11. Loosen the screws in the shaft muff, pull the shaft off and replace the motor.
9. See figure 12. Before remounting the pump shaft, remove any dirt and grease from the motor shaft and the muff's internal clamping surfaces. Mount the pump shaft loosely. Position the balance hole above the keyway.
10. Fit the back plate and extension frame over the shaft.
11. Tighten the bolts.
12. Stand the pump back on its legs/bracket.
13. Fit the impeller and secure it with the cap nut/inducer.

Remember to use the proper tightening torque:

M10:	45 Nm	(33 lbf ft)
M14:	70 Nm	(52 lbf ft)
M20:	200 Nm	(148 lbf ft)



## 5. Maintenance

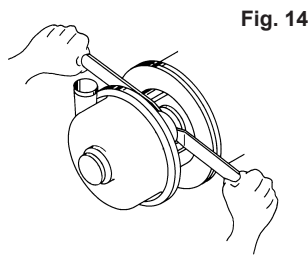
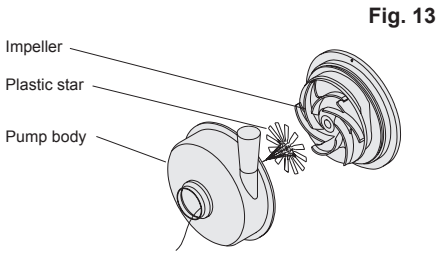

14. Lay the plastic star against the impeller (fig. 13).
15. Fit the pump body (item 1a,1b) with the clamp ring (item 8).
16. Push the shaft (item 10) forward until the impeller (item 4) is touching the plastic star (fig. 14).
17. Tighten the shaft screws. Remember to use the proper tightening torque:
 

M8:	30 Nm	(22 lbf ft)
M10:	55 Nm	(41 lbf ft)
M12:	80 Nm	(59 lbf ft)
M16:	180 Nm	(132 lbf ft)
18. Remove the star by pulling it out through the inlet.

### 5.4 Recommended stocks of spare parts

#### Seal set

We recommend that you keep both seal kits and service kits for the PUMA+ pumps in stock. The seal kit for the PUMA+ pump consists of the wearing parts of the pump, as specified on page 45 - 46.

#### Service kit

The service kit is made up of a number of the main components of the pump which are not wearing parts, but which you still may have to replace: shaft, impeller, cap nut and fixing kit.

The table below shows the recommended stocks of spare parts for normal operation and in cases where there are special needs - for example 24-hour operation, operation with abrasive media, or processes that are sensitive to even the shortest production stoppage.

#### Wearing parts (seal kit, see page 45 - 46)

	No. of pumps in service		
	0-5	5-20	> 20
	Sets	Sets	Sets/ 10 pumps
Normal operation	2	3	1
Special needs	3	6	2

#### Service parts (shaft, impeller, cap nut page 37, fixing kit page 43 - 44)

	No. of pumps in service		
	0-5	5-20	> 20
	Sets	Sets	Sets/ 10 pumps
Normal operation	0	1	1
Special needs	1	2	1

---

## 6. Technical data

---

### 6.1 Sound pressure and sound effect level for PUMA+ Pumps

Measurements have been carried out in accordance with ISO 3743, Grade 2, and ISO 3746, Grade 3. Tolerance:  $\pm 3$  dB.

LpA in dB refers to the sound pressure level at a distance of one metre from the surface of the pump at a height of 1.6 m above floor level (cf. EC Directive (89/392/EEC) 1.7.4.).

The noise level may increase considerably, if reducers (reduction/expanding fittings) are mounted on the inlet/outlet.

Below values apply when the pumps run at 2900 rpm and have a shroud over the motor. If the pumps are run at 1450 rpm, the values are reduced by about 20 dB.

The sound level is between 60 and 80 dB(A). The values depend on operating point, product, and suction conditions.

### 6.2 Maximum permissible outlet pressure for PUMA+ Pumps

The maximum pump outlet pressures specified below must not be exceeded (applies to water at 20°C).

**Max. 16 bar:** PUMA+10, PUMA+20, PUMA+30

The above values also apply to the corresponding models in the PUMAi+ versions.

### 6.3 Tightening torque for impeller, inducer and shaft

Tightening torque required for the screws in the shaft muff and for body bolts (pumps not fitted with clamp rings):

M8:	30 Nm	(22 lbf ft)
M10:	55 Nm	(41 lbf ft)
M12:	80 Nm	(59 lbf ft)
M16:	180 Nm	(132 lbf ft)

Tightening torque required for the cap nut and inducer:

M10:	45 Nm	(33 lbf ft)
M14:	70 Nm	(52 lbf ft)
M20:	200 Nm	(148 lbf ft)

Subject to changes.



Your local contact:



APV, An SPX Brand,  
Platinvej 8  
6000 Kolding, Denmark  
Phone: +45 70 278 444 Fax: +45 70 278 445

For more information about our worldwide locations, approvals, certifications, and local representatives, please visit [www.apv.com](http://www.apv.com).

SPX reserves the right to incorporate our latest design and material changes without notice or obligation. Design features, materials of construction and dimensional data, as described in this bulletin, are provided for your information only and should not be relied upon unless confirmed in writing. Certified drawings are available upon request.

341807 ISS T 11.2008

Copyright © 2008 SPX Corporation