

STANDARD HYBRID HEAT EXCHANGER ENGLISH



Read and understand this manual prior to operating or servicing this product.

Always observe the Safety Notes designated by a warning symbol, listed throughout this manual.



As these units operate with potentially dangerous fluids/gases and are capable (in certain circumstances) of releasing potentially dangerous mediums – there are clearly H&S issues that the Customers' organisation must be aware of and take the necessary safety precautions for the safe operation of the unit. Please refer to the Hazard Analysis supplied with the final documentation pack for further details.



Do not lower the apparatus on the connecting pieces, flanges or other connections.
To ensure personal safety, please be aware of the dimensions and weights before transportation, e.g. from the dimensional drawing or parts lists.



Ensure force and moment free connections if the manufacturer has not calculated the maximum load on the connecting pieces separately.

Provide the feeding tubes with appropriate bellows and fixed points.
Ensure that the connections are not subjected to forces that could lead to damage.



Safety valves are not included in the standard scope of delivery. Their installation and provision is the responsibility of the user.



The Customer is responsible for ensuring that no operating, commissioning or testing conditions will exceed the maximum permissible differential pressure. If the maximum permissible differential pressures are exceeded, this may cause damage to the plate package. The maximum allowable operating and differential pressures are detailed in the final drawing package.



Bare surfaces > 50 °C involve combustion risk in the operating mode! The operator must ensure suitable protective measures! This is also applicable for heat exchangers with low operating temperatures < -25 °C.



Ventilation and drainage of the apparatus involve a risk of scalding in case of products with temperatures >50 °C and burning in case of aggressive media! Take appropriate safety and precautionary measures before ventilating and draining!



The vents are opened for filling and draining the medium.
It is closed during normal operation.
Open the ventilation from time to time when the exchanger is in operation to check whether the medium is 100 % full.
See section 6.2 for ventilation requirements during commissioning



Hybrids are heavily constructed units, weighing (in most cases) several tonnes. Please refer to the the Final Assembly drawing for the actual weight of the unit supplied). The Customer (or agent) is advised to seek specialist assistance for the lifting, positioning and installation of the unit.



The nozzles must not be used to lift the unit as the housing can be damaged and this may cause leakage of the process fluids or major, external failure of the pressure vessel itself when commissioning commences - which will have serious H&S issues associated with this type of failure. The specific lifting lugs must be used to lift the unit at all times– refer to final assembly drawing. Also, no other parts of the machine is to be used as a lifting points (only the approved lifting lugs)



The unit is susceptible to damage if subjected to physical impacts.
These must be avoided at all times while being lifted or moved.



Ensure that the tube and corrugated (wave) circuits are connected correctly (the right way around) – as this could easily damage the unit beyond repair
Ensure that vents are open (to allow for air bleeding).
Refer to Section 5 for the full ventilation requirements.



Furthermore, it must be ensured that the maximum permissible differential pressure for the operating conditions and the pressure test on both sides is not exceeded (also refer to section 4.1).
The start-up ventilations must remain open till the corresponding space is air-free.



Please refer to section 4.1 regarding pressure control requirements (maximum operating & differential pressure requirements)



The APV heat exchanger may be used only for the directed purpose. Using in any other manner is explicitly forbidden. The heat exchanger may be operated, serviced and if necessary repaired only by technical personnel and by adhering to all legal stipulations.



The Customer is required to nominate materials that are capable of sustaining long-term performance with the specified chemicals present in the fluid mediums (e.g. especially chlorides at elevated operating temperatures). Failure to control chemical levels in the mediums may result in premature corrosion of the plate pack and subsequent failure of the heat exchanger.



For "Oil and Gas" related applications the H₂S content is to be considered. H₂S is a strong poison. For this reason it is essential to choose the right material to avoid dangerous leakages and the possible impact on health and safety of operators/ employees.



Under no circumstances must the unit be operated outside the specified design conditions stated on the name plate (also detailed in the drawing package)



The heat exchanger must be specifically designed to operate in a vacuum condition if this is to be part of normal operating conditions.

Contents

0	Preface	4
1	Design and function description of the HYBRID plate heat exchanger	7
2	Design data	9
3	Transportation, installation, tube connection	10
3.1	Transportation	10
3.2	Installation	11
3.3	Tube connection	11
4	Equipment instructions	12
4.1	Maintaining maximum operating pressure	12
4.2	Maintaining maximum operating temperatures	12
4.3	Insulation	12
4.4	Maintaining the liquid level in the tank	12
4.5	Mounting a prefilter	13
5	Ventilation and drainage	14
6	Commissioning, operating and operating conditions Instructions for conservation during standstill	15
6.1	Preparations for commissioning the HYBRID heat exchanger	15
6.2	General instructions and remarks for commissioning and operating the HYBRID heat exchanger	16
6.3	Operational interruptions	17
6.4	Wet Storage	18
6.5	Dry Storage	18
7	Monitoring during operation	19
8	Operational disturbances	20
9	Quality Assurance	21
9.1	Checks	21
9.2	Servicing	21
9.3	Cleaning the HYBRID plate heat exchanger	21
9.4	Safety instructions	23
10	General information	24

Appendix I

1: First principals of Hybrid heat exchanger design

0 Preface

Associated Documents:

- Product Specification
- Contract
- Final product documentation pack supplied by SPX
- Hazard Analysis
- Design drawing package
- Data Sheet

Health & Safety Warning:

The Customer is advised to thoroughly review this manual and all associated documents before commencing installation, commissioning or operation of the heat exchanger as they contain essential Health and Safety information.

Operational Warning:

The end user of the equipment must follow the start-up procedures for hybrid heat exchangers (both for commissioning and normal operation) as substantial damage can occur to the unit if incorrect procedures are adopted.

Acronyms Used

PED	(European) Pressure Equipment Directives
ASME	American Society of Mechanical Engineers
QA	Quality Assurance
ISO	International Standards Organisation
H&S	Health & Safety
SQL	Safety Quality Licence for Boilers and Pressure Vessels (Chinese Standard)
P&ID	Piping & Installation Diagram
OEM	Original Equipment Manufacturer

Specification Data Sheet

The agreed thermal specification of the unit is detailed in the data sheet and must be read in conjunction with this Service and Operating Manual. The Data Sheet is concerned with the principal mechanical design of the plate pack. The pressure vessel (housing) is detailed in the general specification.

Health and Safety (H&S) Requirements

A clear understanding of the requirements to ensure the safe installation, commissioning and long-term service of the equipment by the customer is considered essential by SPX. This manual therefore details the safe practices required for the unit. If the Customer organisation has any issues or concerns with H&S related to the unit, please contact SPX directly via the contact details on the front cover of this document before commencing with the installation, commissioning or operation of the equipment.

In this manual all H&S and critical operating requirements/issues are identified with the following symbol:



Experience/Knowledge of Hybrid units and their application

This manual is based on the Customers' engineering organisation having a working knowledge of the first principal application of hybrid heat exchangers. If there is any doubt that this knowledge exists, then please contact SPX before commencing with the installation, commissioning or operation of the equipment.

Any consultancy service provided by SPX shall be subject to agreement of associated commercial terms, and shall not relieve the customer from its liability for implementing proper health and safety practices.

Appendix of this manual offers some basic, first principal guidelines only, and is not designed to replace good engineering knowledge/practice in the customer's organisation.



As these units operate with potentially dangerous fluids/gases and are capable (in certain circumstances) of releasing potentially dangerous mediums – there are clearly H&S issues that the Customers' organisation must be aware of and take the necessary safety precautions for the safe operation of the unit. Please refer to the Hazard Analysis supplied with the final documentation pack for further details.

Note: the Hazard Analysis provides details on:

- 1) Project information
- 2) Working parameters
- 3) Used materials
- 4) Danger potential
- 5) Design Rules
- 6) Assembly and Commissioning
- 7) Operating & Maintenance manual link

The Customer is required to develop, implement and maintain a comprehensive H&S plan for the installation, commissioning and in-service life of the heat exchanger.

Design Standards

SPX works, as standard, to the following design standards. Any specific Customer requirements are agreed as part of the contract to supply.

- PED 97/23/EG
This is the European Pressure Equipment directive. Designed according to EN 13445
- ASME Section VIII Div. 1 (newest edition)
By agreement with the Customer ASME designed units can be manufactured and supplied.
- Manufacturer licence PRC pressure vessels
Chinese quality standard
- ISO: 9001:2000
SPX works to recognised ISO 9001:2000 quality management system.
Cert No. 1510031701

The Supplied Heat Exchanger

The heat exchanger is supplied as a single unit to a defined & manufactured to the customer's specification. SPX are not familiar with a Customers' plant systems or production processes or over-all fluid-mechanical system and SPX will only warrant in its commercial contracts the performance of the unit against the specification supplied and not the performance of the Customers plant or manufacturing process. For the avoidance of doubt no warranty whether express or implied shall apply within this manual.

1 Design and function description of the HYBRID plate heat exchanger

The core of the HYBRID heat exchanger is a completely welded plate pack. This plate pack consists of embossed shaped plates. The material of the plate pack can be made of different stainless steel alloys and nickel alloys (dependent upon application requirements)

A flow cross-section is created on one side due to a special type of embossing on the plates, the layout of the plates with respect to each other and the staking of the plates. The flow cross-section corresponds to the structure of a number of internal tubes.

A wave flow cross-section is created on the other side of the heat exchanger due to embossing. The wave flow (Corrugated side) of the plate pack has thermal hydraulic properties that resemble those of gasketed plate heat exchangers, while the tube side of the plate pack has thermal hydraulic properties that resemble the tube side of a tube and shell heat exchanger.

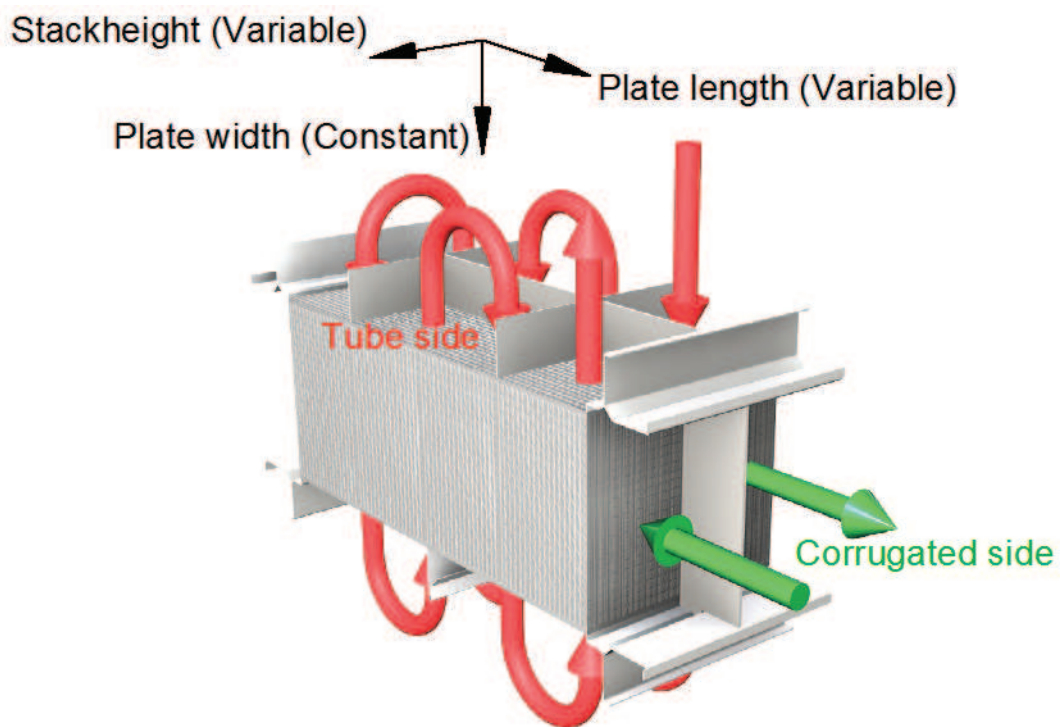

Fig.1: Plate pack of a HYBRID heat exchanger

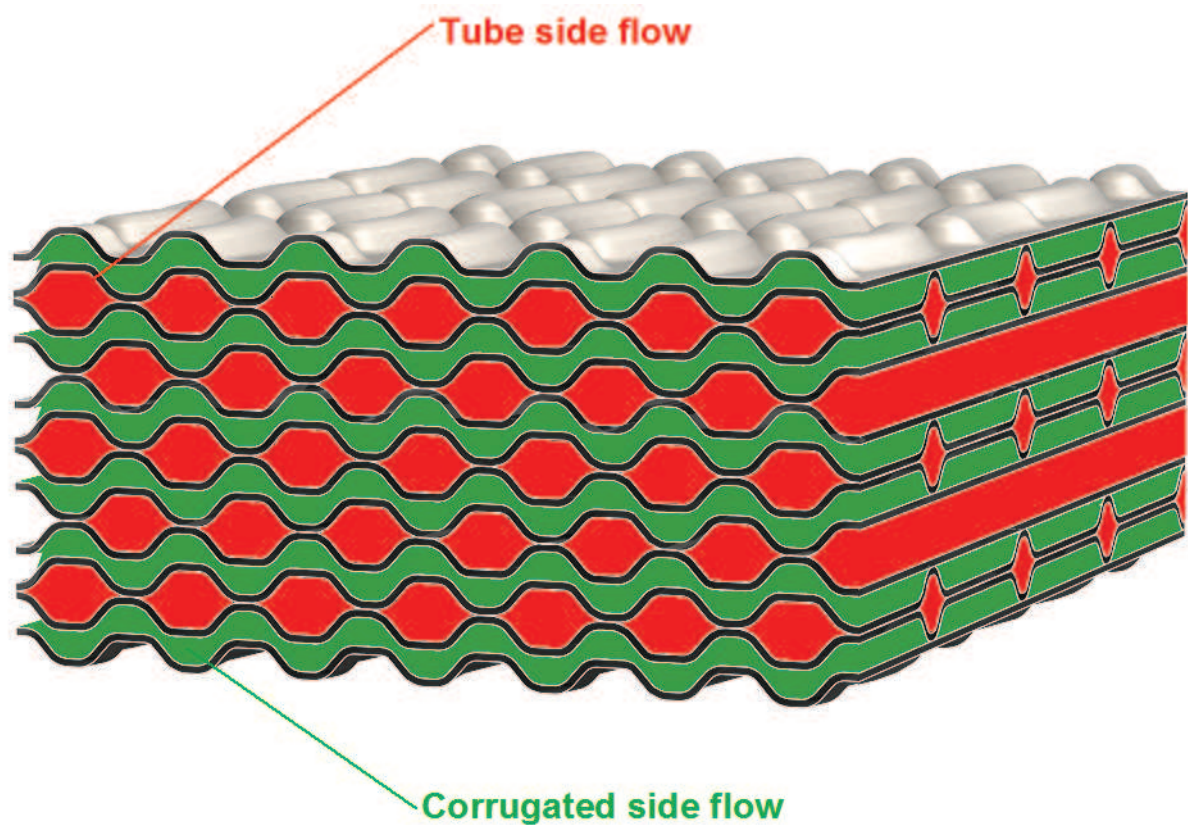

Fig.2: Sectional view of the plate pack (cross flows)

The plate width is constant, 360 mm. The plate length can be variable, from 441 mm up to 2592 mm. A complex embossing tool is been used to press the plates. The deformation height (embossing depth) varies from 2.8 to 3.7 mm.

A so-called shaped plate is created when two embossed plates are laid on top of each other, and welded together. The tube flow cross-section and the plate pack are formed due to piling and welding the shaped plates. The tube side is separated from the corrugated side via a plate profile that is welded to the corners of the plate pack (Fig.1).

The completely welded plate pack can be build into a pressure-resistant housing having a design suitable for the specific application. Inlet and outlet are welded onto the housing.

The HYBRID heat exchanger can be operated and installed horizontally or vertically depending on the application. The wave or tube side volume flow can be guided through one or more channels depending on the variations in design.

The type of installation and the flow medium are given in the accompanying data sheet and the apparatus drawings.

Dimensions and other design-related details including the position and total number of connecting pieces are specified in the accompanying dimensional drawing. Materials used in the pressure-resistant components are given in the parts list in the final documentation. The pack is normally made of SS316L material and the housing (pressure vessel) is made of Carbon-steel. If materials prescribed by the customer / operator are used exclusively, then the customer / operator is responsible for their chemical resistance.

2 Design data

Apart from significant information, the design data, maximum rating and dimensions are clearly given in the accompanying data sheet (Annex 1) as well as in the accompanying drawing and the identification plate.

3 Transportation, installation, tube connection

3.1 Transportation

The apparatus can be transported horizontally or vertically depending on its size. However, please ensure that the belts/ropes/chains are not fastened over the welded connecting pieces. The connecting pieces can be damaged due to the dead weight.

Mounting brackets with lifting points are bolted onto the heat exchanger. These are required during transportation using suitable elevators (refer to the accompanying dimensional drawing). The apparatus is however fastened over the body using belt conveyors if loops or support straps are not available.



Do not lower the apparatus on the connecting pieces, flanges or other connections. To ensure personal safety, please be aware of the dimensions and weights before transportation, e.g. from the dimensional drawing or parts lists.

Only approved lifting points may be used for lifting the unit:

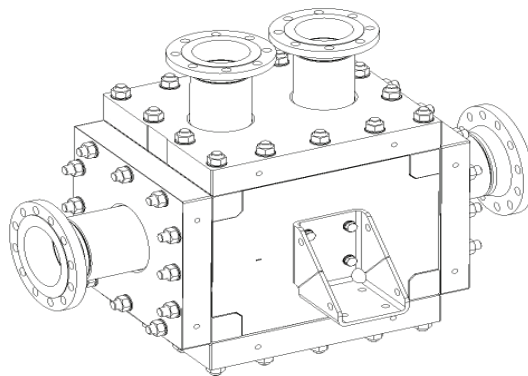

Feet & Lifting Bracket

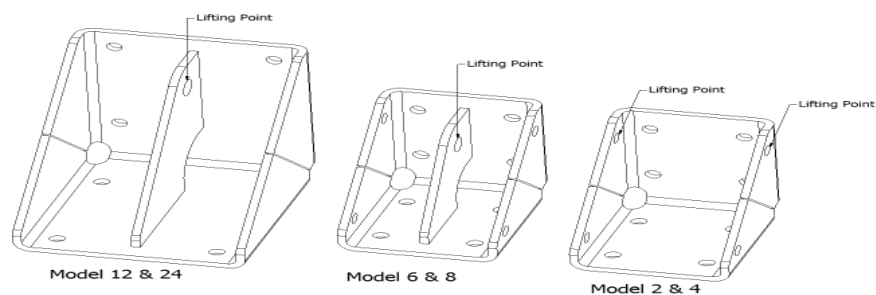

3.2 Installation

The place of installation must be selected after considering the following conditions:

- The heat exchanger must be accessible from all sides in case any checking or servicing is required.
- Instrumentation for level indicators, ventilation, drainage, etc. must be possible without causing any damage.
- Other components should not conceal the local measurement points.
- All detachable inlet/ outlet covers, fixed equipment or attached parts should be easily removable.
- Consider the dead and operating weight of the heat exchanger as well as its weight during the pressure test (specified in the accompanying dimensional drawings and parts lists) while selecting the substructure or the base.

3.3 Tube connection

Connect the connecting pieces on the heat exchanger as per the dimensional drawing. Seal the unnecessary connecting pieces using a blank cover or a sealing cap. Do not connect the ventilation and the drainage pipes for the various pressure spaces via a manifold.



Ensure force and moment free connections if the manufacturer has not calculated the maximum load on the connecting pieces separately.

Provide the feeding tubes with appropriate bellows and fixed points.

Ensure that the connections are not subjected to forces that could lead to damage.

Subsequent welding on any part of a certified pressure-resistant housing (pressure vessel) is not permitted by PED or ASME regulations without specific approval from a qualified and certified organisation. This action may cause the pressure vessel to fail in a dangerous condition.

Vibrations and oscillations due to upstream or downstream system components must not occur in the heat exchanger.

Additional fittings like level indicator, safety valves, temperature and pressure measurement positions, etc. (not a part of the standard supply scope) must also be detachable, so as to avoid any damage during transportation. Tooling is done onsite.

4 Equipment instructions

Take proper operating measures, so that the maximum operational parameters are not exceeded.

4.1 Maintaining maximum operating pressure

In order to ensure that the maximum permissible operating pressure (design pressure) is not exceeded for closed piping systems, the corrugated and tube sides must be provided with one safety valve each.



Safety valves are not included in the standard scope of delivery. Their installation and provision is the responsibility of the user.

If the apparatus has connections for these safety valves, they are to be installed there. If the heat exchanger is not equipped with them, the valves must be installed in the supply and discharge pipe before the first shut-off device.

Maximum Differential Pressures



The Customer is responsible for ensuring that no operating, commissioning or testing conditions will exceed the maximum permissible differential pressure. If the maximum permissible differential pressures are exceeded, this may cause damage to the plate package. The maximum allowable operating and differential pressures are detailed in the final drawing package.

4.2 Maintaining maximum operating temperatures

Protection against exceeding the maximum operating temperatures must be ensured in accordance with the control technology by using temperature limiters, pump or blower control systems, control dampers or valves or via bypasses.

4.3 Insulation

The heat exchanger should be provided with a thermal insulation unit or a contact safety device (not a part of the SPX standard supply scope). An appropriately dimensioned thermal insulation unit reduces the loss of heat radiations and also acts as a contact safety device.



Bare surfaces > 50 °C involve combustion risk in the operating mode! The operator must ensure suitable protective measures! This is also applicable for heat exchangers with low operating temperatures < -25 °C.

4.4 Maintaining the liquid level in the tank

Depending on the application scope of the apparatus, it may be necessary to maintain a specific level of the liquid in the tank. The normal level is mentioned in the dimensional drawings. The device required for monitoring and controlling the level is not included in the supply scope.

The heat exchanger may fail to function if the normal level is not attained.

Examples:

Application

Condenser with a sub-cooling zone

Natural circulation evaporator

Seal for gaseous or vaporous

Malfunctions, if the level is not attained

Outlet temperature of the condensate rises as calculated (subsequent expansion may cause evaporation)

The apparatus acts as a direct evaporator; circulation is no longer guaranteed

A two-phase mixture can be admitted to media downstream pumps (Cavitation possible)

The HYBRID heat exchanger can be equipped with a level controlling unit for maintaining the liquid level.

4.5 Mounting a prefilter

Install a pre-filter with a mesh width of 3 – 4 mm in the feeding tube for avoiding coarse dirt in the plate pack. This is not required for clean media. There is a basic engineering rule for hybrid heat exchangers that “mesh size must be one half of the plate gap”

5 Ventilation and drainage



Ventilation and drainage of the apparatus involve a risk of scalding in case of products with temperatures $>50\text{ }^{\circ}\text{C}$ and burning in case of aggressive media! Take appropriate safety and precautionary measures before ventilating and draining!

The heat exchanger is equipped with additional connecting pieces for ventilation and drainage. The connecting pieces are attached to the highest point (for ventilation) and/or at the lowest point (for drainage) of the unit. The positions for the ventilation and the drainage connecting pieces are given in the dimensional drawing

If the heat exchanger is not equipped with additional connecting pieces, then these must be provided onsite in the feeding and discharge tubes also at the highest and lowest point.

General Ventilation Requirements



- The vents are opened for filling and draining the medium.
- It is closed during normal operation.
- Open the ventilation from time to time when the exchanger is in operation to check whether the medium is 100 % full.
- See section 6.2 for ventilation requirements during commissioning

Refer to Warning on potentially hazardous medium release

If the HYBRID heat exchanger is operated in a vacuum region, then evacuation must be done before commissioning using the start-up and the operational ventilations. Ventilation during the operation is provided constantly and carefully using the operational ventilations. The start-up ventilations are closed after the outlet temperature of the medium is attained corresponding to the load.

6 Commissioning, operating and operating conditions Instructions for conservation during standstill

Heavy Equipment Warning



Hybrids are heavily constructed units, weighing (in most cases) several tonnes. Please refer to the the Final Assembly drawing for the actual weight of the unit supplied). The Customer (or agent) is advised to seek specialist assistance for the lifting, positioning and installation of the unit.

Warning – Lifting Points:



The nozzles must not be used to lift the unit as the housing can be damaged and this may cause leakage of the process fluids or major, external failure of the pressure vessel itself when commissioning commences - which will have serious H&S issues associated with this type of failure. The specific lifting lugs must be used to lift the unit at all times– refer to final assembly drawing. Also, no other parts of the machine is to be used as a lifting points (only the approved lifting lugs)

Warning – External, Physical Shock Impacts



The unit is susceptible to damage if subjected to physical impacts. These must be avoided at all times while being lifted or moved.

6.1 Preparations for commissioning the HYBRID heat exchanger

Read the entire operating and service manual and supporting documentation.

Check the supports for the unit:

- unit properly supported with a structure that is capable of supporting the weight of the unit and will be unaffected by the unit's operating temperatures (complete range of temperatures).
- all securing bolts are correctly tightened
- Check the bolts of the connecting rod screws (threaded rods) attached at the pressure-retaining plate and the flange screws of the detachable square-flange covers, are torque to the correct setting before use. Refer to starting torques given in the drawing before commissioning.
- Check all connected and joined tubes for appropriate connections as per the circuit and the function
- Check for the completeness of the fittings and measurement points corresponding to the system circuit diagrams (not a part of the SPX – supply scope) and proper and functional installation.

Instructions

The aforementioned checks are necessary only during initial commissioning and after modifications or repairs.

- Set up all level monitoring devices including signalling and possible switch-off and switch-over processes. Execute functional tests for the devices if necessary.
- Set up the flow control units and if necessary execute functional tests.
- Set up the level indicator (local / remote) and if necessary execute functional tests.
- Check the start-up and operational ventilations (refer to point 5).

- Set up the temperature and pressure measurement points (local / remote) and if necessary execute functional tests.
- Set up the upstream and downstream system components.
- Fill the HYBRID heat exchanger. The ventilations are opened for liquid media and closed only after the liquid (air-free) is discharged.
- Change of gaskets on flanges according to rules of gasket suppliers and according to remarks in drawings and part lists SPX

6.2 General instructions and remarks for commissioning and operating the HYBRID heat exchanger

The different system circuit diagrams (not a part of the SPX – supply scope) clearly indicate the layouts and integration of the HYBRID heat exchanger into the various systems.

The time for commissioning the heat exchanger is ascertained as per the start-up process of the entire system or it depends on the operational requirements.

Consider the instructions and specifications given in the applicable safety rules while commissioning and operating and also while starting the system.

Required Commissioning Procedure



- Ensure that the tube and corrugated (wave) circuits are connected correctly (the right way around) – as this could easily damage the unit beyond repair
- Ensure that vents are open (to allow for air bleeding).
Refer to Section 5 for the full ventilation requirements.

Warning: make sure that no hazardous vapours are released to the local atmosphere or to the ground – this may cause injuries or damage to the environment.

Note: if hazardous fluids are present in the heat exchanger, the venting nozzles must be routed to a closed loop system.

As pressure impacts (shocks) may damage the apparatus, the fittings (valves) must operate slowly at the time of filling. As a result, pressure on the corrugated and tube sides rises gradually. Pressure shocks are to be avoided at all times as they can damage the plate pack



Furthermore, it must be ensured that the maximum permissible differential pressure for the operating conditions and the pressure test on both sides is not exceeded (also refer to section 4.1).

The start-up ventilations must remain open till the corresponding space is air-free.

Recommendation:

Suitable gauges should be installed in the fluid circuit, near the heat exchanger, so that operating pressures can be observed and managed.

The HYBRID heat exchanger should heat up / cool down gradually at the operating temperature. Temperature shocks must be avoided.

Please ensure that the maximum permissible temperature-transient of 5 °C / min is not exceeded during the operating phase for avoiding non-permissible thermal stress. The

operating pressure must always be higher than the saturated steam pressure in order to avoid evaporation. Evaporations will damage the apparatus.

The maximum temperature difference of 125 °C should not be exceeded in a normal HYBRID design.

The total operating pressure should be set only after attaining the operating temperature. Please ensure that the liquid levels and control ranges are adhered to. Exceeding or remaining below the levels or ranges may lead to functional disorders and possible damages.

Vibrations and oscillations are not permissible in upstream or downstream system components.

The HYBRID heat exchanger including the measuring devices and control units must be checked during operation not later than 6 months after commissioning and from then on at least 1x a year. Rectify the faults in the measuring devices and control units immediately. It is recommended to record and archive important operating data (inlet and outlet temperatures and pressures, at least 1 mass flow) periodically.

If a leakage is suspected, switch off and examine the HYBRID heat exchanger so as to avoid secondary damages. Rectify all possible leakages before restarting the heat exchanger to avoid consequential damage.

6.3 Operational interruptions

In case of operational interruptions exceeding 100 hours, the two separate pressure spaces of the heat exchanger must be conserved against standstill corrosion (refer to 6.4 and 6.5).

The apparatus must be protected against standstill corrosion in the design phase as well as while modifying. While modifying, please ensure that dirt does not settle in the open connecting pieces. Dirt particles may damage the fixed equipment.

The apparatus may stop to operate correctly due to chloride accumulations if it has come in contact with flow media containing chlorides. Localised corrosion may also result depending on the material of the heating surfaces. It is essential that the end user ensure that chloride or other corrosion ending chemicals are kept to within the specified parameters. Should the unit fail due to corrosion the user must stop operational use of the unit until a qualified assessment can be made of the potential damage to the unit.

If the End User's organisation has not the necessary experience in evaluating corrosion related failures please contact SPX via the detail on the front cover of this manual.

Dry or wet conservation must be executed in case of predetermined risk.

To prevent damages during standstills due to freezing, the tube as well as corrugated sides of the heat exchanger must be completely emptied.

The conservation procedure to be followed must be decided upon depending on the respective local circumstances and possibilities as well as the climatic conditions and the operating mode.

6.4 Wet Storage

This type of conservation can be implemented only if there is no risk of freezing. The conservation period for this process is unlimited.

The quality of the filling water should be maintained at the same level by analysing the conservation liquid at regular intervals, circulating the liquid every week and replacing the used chemicals*. Nitrogen padding can be used to seal the conservation liquid from the atmosphere.

Please refer to your local authorities for the "Conservation of power plant systems"

* Ensure that any additives to the system or replacement/top-up chemicals are "fit-for-purpose" and unlikely to cause damage to the pate pack or supporting systems.

6.5 Dry Storage

Conservation period for this process is unlimited. This process is implemented in case of longer standstills. The apparatus must be absolutely dry before nitrogen or dry air can act on it. This for example can be done by blowing hot air into the apparatus after emptying it completely. The drying process is complete when the relative moisture of the air blown in matches that of the discharged air.

The conservation air to be blown in must be free from oil, dirt and aggressive components. It can be generated in large quantities in a relatively easy manner using a regenerative adsorption dryer. The discharged conservation air should have relative air moisture < 30 % at 20 °C.

The wall temperature of the heat exchanger should be more than the dew point of the air, so that formation of condensation water can be avoided.

Also a vacuum drying and filling with dry nitrogen afterwards can be carried out. The dew point of the nitrogen after filling is to specify in advance. Conservation measures should be verified at regular intervals.

7 Monitoring during operation

Check: Supports of the apparatus

Check: Tightness of connections/ flanges

Check: Tightness of Gaskets

Check: Tube side / corrugated side connections, flanges and gaskets

Check: Pressure of the medium on the tube / corrugated side

Check: Inlet and outlet temperatures of the media
(Thermal function)

Check: Mass flow on both sides

Check: Operational ventilations

Check: Safety and monitoring devices

Check: No physical leakages from:
- the main unit
- flange connection

Warning: if there are physical leakages, containment actions in accordance with local H&S laws regarding chemical spillages must be followed. It is the responsibility of the Customers H&S Officer to ensure that procedures are in place for these potential events and must be considered in any risk analysis carried out for the unit in its final operating position.

Remark:

Any accumulation of air and gas must be removed. Accumulation of air and gas in the heat exchanger leads to:

- a) disturbances in the thermal functioning/unit efficiency
- b) possibility of corrosion.

8 Operational disturbances

The design data was not adhered to.

Cause:

Air and gas accumulations on the corrugated and tube sides.

Measures:

- Thorough ventilation of the corrugated and tube sides
- Check the valve openings in the ventilation pipes; secure the valves against unintentional closing during operational ventilation (vacuum operation)
- Check the ventilation pipes
- Check the flange joints
- Check the heat exchanger and the connecting tubes for open connecting baffles (manometer, thermometer and reserve connections).

Remark:

If the heat exchanger is operating in the vacuum region, a lot of air may penetrate into the flanges of the connecting pieces. This air cannot be extracted completely using the existing ventilation cross-sections. The leakages must first be repaired in such a case. If these measures are not successful, then the openings of the operational ventilation valves must be enlarged.

Cause:

Covering the heat exchanger surface

Measures:

Cleaning the plate pack (refer to point 9.3)

9 Quality Assurance

9.1 Checks

Depending on local country law, it may be required to periodically test the unit.

The Customer is advised to verify with local authorities on their particular requirements for periodic checking.

These periods are applicable as per the latest technological development without considering any special conditions prevailing at the place / country of installation.



Please refer to section 4.1 regarding pressure control requirements (maximum operating & differential pressure requirements)

In case of longer standstills, for which no official tests have been specified, it is recommended that at least a visual inspection of the components must be executed. Only the manufacturer or the company appointed by the manufacturer can undertake works within the guarantee period.

9.2 Servicing

Check for leakages in the flange and gasket joints, at regular intervals.

Leakage tests and pressure tests should be executed till the maximum operating pressure. We recommend a pressure rise of maximum 1 bar/min for a long service life; pressure impacts must be avoided.

9.3 Cleaning the HYBRID plate heat exchanger

Cleaning agents are guided through the apparatus instead of the operating medium. Dirt particles are removed due to the dissolving ability of the cleaning agent.

The flow is increased or its direction is reversed (counterflow) for better cleaning. Due to higher turbulences, the increased flow rate causes a mechanical effect. Better solubility at the surface coating can also be attained by heating the cleaning agent.

The cleaning agent must be selected depending on the type and coating of the dirt to be removed.

Important: Before selecting the cleaning agent, check its compatibility with the materials that are used or consult the concerned company.

The cleaning liquid should be prepared using water that is free from chloride (e.g. de-ionised water) and is less hard. Rinse using adequate clean water after the cleaning process is done.

Provide separate washing/ cleaning connections in the tubes if an apparatus having media that form a coating on the surface is used.

High pressure cleaning

If cleaning with chemicals is not sufficient, the slabs need to be removed for high pressure cleaning. Plate types TuplaFlow 37 and TuplaFlow 28 are fully cleanable on tube side. EnergySave plate and corrugated side on TuplaFlow 37 and 28 are only cleanable in both end of the plate pack. By high pressure cleaning, be careful not to damage the plates.

Before removing a slab

- Mark the slabs. To ensure the slabs are being mounting in the same way again.
- Check that none of the two circuits are under pressure.
- Ensure that the two circuits are drained of fluids / media

When cleaning, the slabs must be removed in pairs. That means, for example remove the two slabs on Tube side (TS). After cleaning TS the two slabs must be mounted again, before removing and cleaning the corrugated side (CS).

It is necessary to loosen all the bolts in the Column, also the Column - bolts on for example CS, when removing TS slabs.

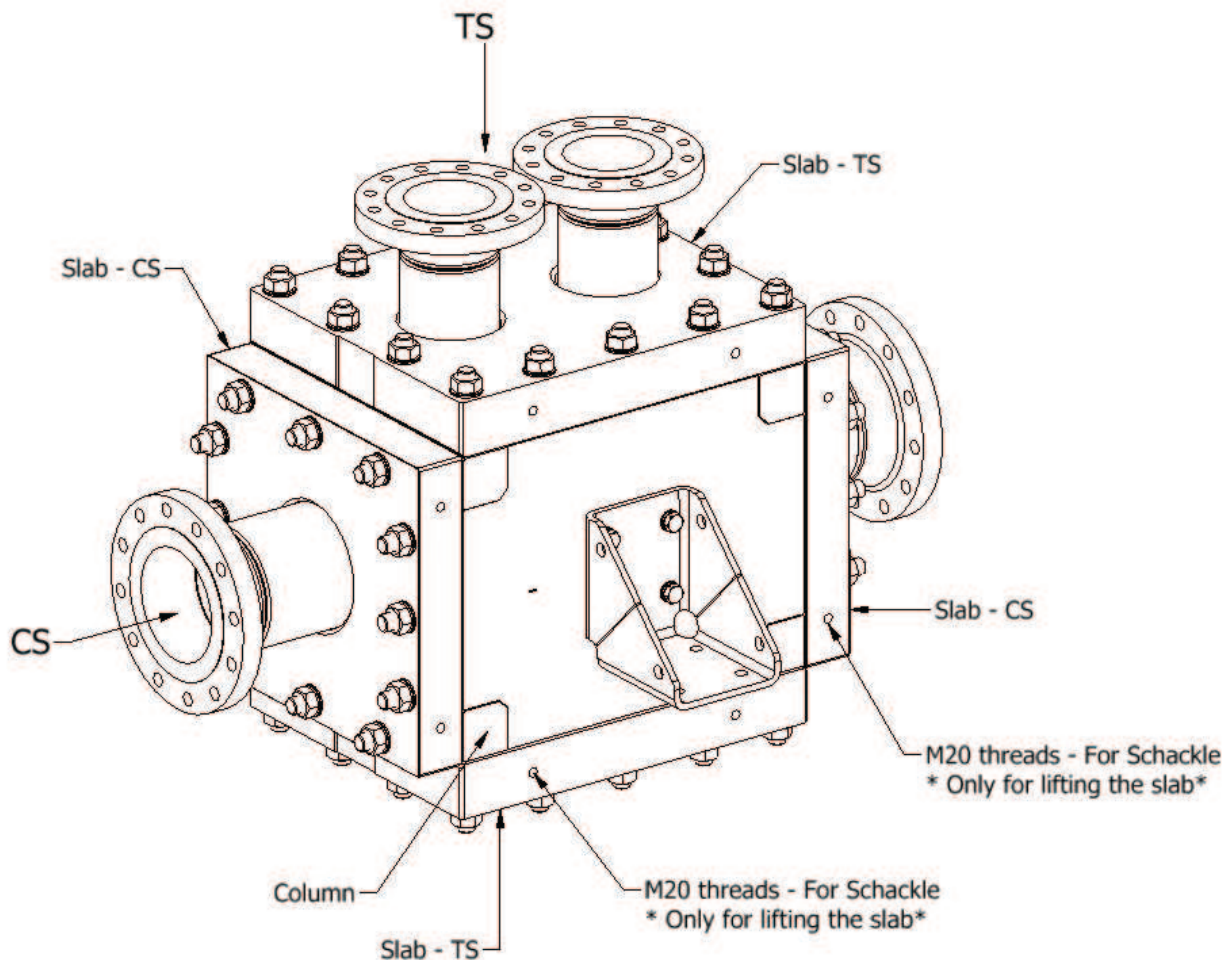

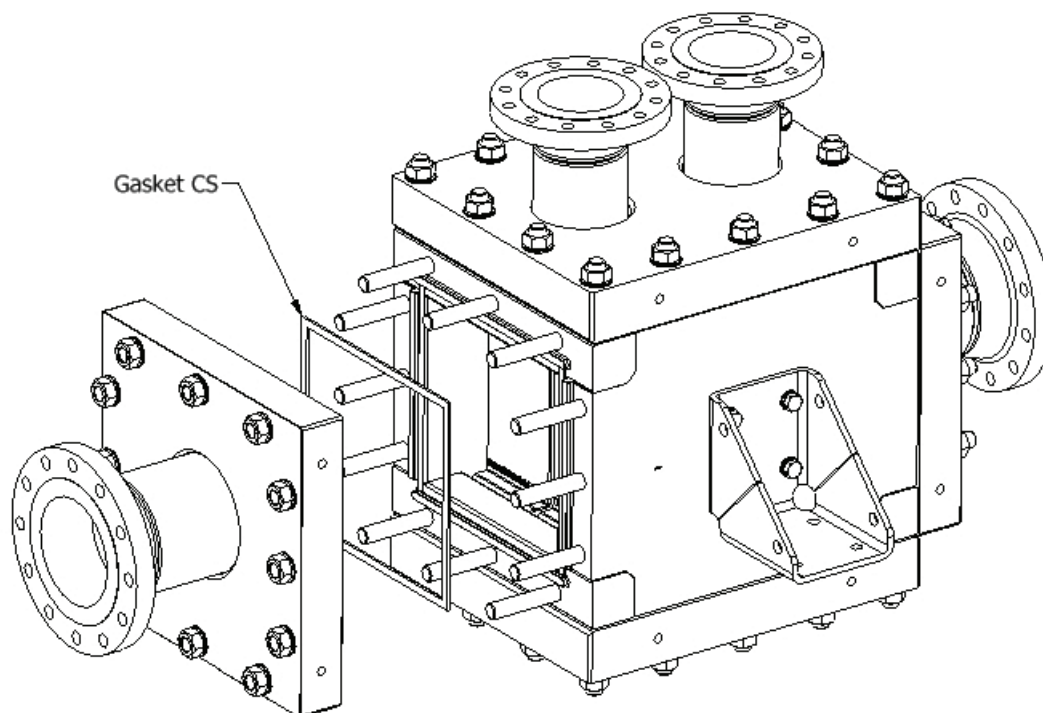

Gasket

When a slab has been removed, for example due to cleaning, it is necessary to replace the gasket afterwards. The type and size of the gasket, can be seen on the as build drawing.

The tightening torque of the bolts can be seen on the as build drawing. When the bolts must be tightened, it is important to cross tighten the bolts. Do not tighten the bolts to full torque at first. Tighten the bolts a little at a time.

9.4 Safety instructions

Apart from the applicable accident prevention measures and the existing safety instructions, the instructions of the supplier must also be followed during inspection and repairs of components and accessories.

The installations / systems and components must be cleared by the responsible operating personnel before starting the operation. Repairs and servicing should be executed only by authorised personnel.

Only approved lifting points may be used for mounting and demounting of slabs, flanges etc. Hereby the risk of work under floating loads is to avoid.

In the context of mounting and demounting of connections, cleaning and access nozzles / flanges the risk of injuring by squeezing is to avoid.

Operating the fittings or opening of flanges involves risk of scalding and/or burning due to the discharge of aggressive and poisonous media.

10 General information



The APV heat exchanger may be used only for the directed purpose. Using in any other manner is explicitly forbidden. The heat exchanger may be operated, serviced and if necessary repaired only by technical personnel and by adhering to all legal stipulations.

The HYBRID heat exchanger must be loaded and unloaded regularly.

Do not exceed the maximum, permissible operating parameters. The heat exchanger can be damaged if the threshold values are exceeded.

Guarantee claims are confined to the basic design parameters for calculating the strength.

Please refer to Appendix I, section 1.2; "alternating loads".

Hand-operated valves should be operated slowly and without using force.

Risk of scalding depends on the operating temperature. The heat exchanger should have a thermal insulation unit or a contact safety device. An appropriately dimensioned thermal insulation unit reduces the loss of heat radiations and also acts as a contact safety device.

A tank / heat exchanger that is exposed to excess pressure during operation is subject to legal stipulations and conditions. The type and scope of the stipulations depend on, for example, size, the media to be heated and cooled, processed materials, place of installation, operation, etc.

The stipulations and conditions applicable for operating the pressure vessels, particularly the safety regulations "Guidelines for pressure devices" must be adhered to e.g. PED - Guideline 97/23/EG and ASME Section VIII Div. 1 (newest edition)

In case of any doubts, send your queries to the respective professional bodies or cooperative societies or contact SPX as detailed on the front cover of this manual.

Weld or replace pressure-resistant parts of the apparatus only after consulting the suppliers and with the approval from the responsible expert at the control centre.

Check the compatibility of the initial product flows with the materials processed in the heat exchanger. The manufacturer shall not be responsible for corrosive damages caused due to chemical reactions. Check and analyse the product flows at regular intervals.

Use the heat economizer as a preventive measure against standstill corrosion during operational interruptions, modifications and in the system designing phase as well. The effectiveness of the conservation measures must be checked constantly.

The OEM (SPX) is not responsible for any operating and servicing errors. The technical engineering or service department (which is applicable in the end user's organisation) in-service regarding operating or servicing the heat exchanger.

Please specify the SPX-Manufacturing-No. (refer to the fascia) and the SPX drawing number in your queries (refer to the documentation).

These documents may neither be copied nor given to a third party, especially a rival company, without our consent. They must not be misused.

Appendix I: First Principals of Hybrids

General Warning:

a) Hybrid Design

Hybrids (as a welded unit) offers exceptional efficiency as they have a large surface area in comparison with the size of the unit, however hybrids have operating considerations that are unique to hybrid construction and differs from (e.g.) a corresponding shell and tube design.

Defined operating principals do exist for the efficient and proper use of a hybrid unit and these must be respected as detailed below.

b) Defining Pressures within the Specification

Normally the datasheets will indicate operating pressures in pressure units (absolute) and design pressure are detailed in pressure units (gauge). It is vital that the Customer specifies the pressure and the relative scales (absolute or gauge).

c) Defining temperatures within the Specification.

This appendix is for generic Hybrid information, factors specific to the Customer's application must be agreed between SPX and the Customers engineering team.

1: Pressure Considerations

1.1: Maximum Differential Pressure

The differential pressures have to be observed carefully through-out the range of operating conditions, including especially test and commissioning conditions. The maximum differential pressures are to be agreed as part of the Customer specific requirements.

Please refer to the assembly drawing to get the applicable differential pressures for both sides of the Hybrid heat exchanger.

1.2: Alternating Loads

Generally, hybrids are designed for a static operating condition (pressure and temperature). An "alternating load" defined as changing pressures (and temperatures) changing over a defined period of time. If the application requires the unit to experience alternating loads these must be specified in the Customer specification as there is an impact on the design of the unit which have to be "embodied" into the mechanical of the unit:

Alternating loads are specified as any number of normal operating conditions and the time taken to transition between the defined operating conditions. Note the start-up condition is part of this requirement – but is a special case of alternating loads (See below)

Generally if there are different operating conditions regarding pressure and temperature in a defined time period – alternating loads are required to be considered as part of the specification

Please refer to SPX specialist for clarification of the end user requirements for inclusion into the design specification.

1.3: Pressure Shocks

These are defined as "spiked" transient loads caused by inappropriate start up of e.g. pumps or the closing of valves, etc.. Spikes can also be caused through steam hammering due to improper start-up/operating for steam condensers.

1.4: Start-up and Close-down of the unit

Hybrid heat exchangers are designed for long-term, static type operating conditions. Frequent shut-downs and start-ups of units are to be considered as an alternating load requirement

Guideline: if the unit is to be shut-down and start-up more than a few times per week than this is a load alternation condition and has ramifications for the long-term integrity of the unit (refer to point 3 above).

Ramped, Start-up Pressure Requirements

It is required that hybrid pressures are built-up over a period of time from start-up. The nature of the core-pack is that it is flexible and can be damaged with particularly harsh start-up pressure ramps. For advice please refer to SPX specialist for your specific application.

1.5: Emergency shut-downs

Emergency shut-down need to be a “controlled event”, with the maximum differential pressures considered as part of the shut-down cycle. Both sides of the hybrids may need to be considered in the shut-down – but this is dependent on the operating design rating of the core pack.

1.6: Emergency Pressure Relief

Please refer to Section 4.1

1.7: Pressure Drops

The customer will define a maximum allowable pressure drop across the unit based on their plant process capability (e.g. pumps). Deviation from the Customers stated specifications in either flow rate or fluid property may result in a higher pressure drop than calculated from the theoretical calculation.

2 Temperature Considerations

2.1 Maximum Operating Temperature

A general Hybrid can be used for application up to 350 deg C. In principal a hybrid can be applied to high temperature applications, however key temperature factors that need to be controlled are:

- Temperature differences (between fluids on both sides) This is a maximum of 150 Degrees Celsius
- The initial start-up phase
 1. The start-up conditions require the temperatures differences in the unit not to exceed 150 Degrees Celsius
 2. Temperature gradients must not be exceeded (refer to Section 6.2)

2.2 High Temperature Applications

For applications whose specification is required to exceed the above limits, units are supplied by SPX as customer specific applications.

3 Fluid Considerations

3.1: Fluid Properties

The Customer's application must state the fluid properties as they are important for the thermal design of the unit, otherwise SPX cannot correctly predict the efficiency of the unit and the corresponding pressure drops.

3.2: Material Choice

The selection of the materials used for the unit is the Customers responsibility. The corrosive nature of the fluids and the abrasive nature of the fluids are both key factors in the choice of the materials.



The Customer is required to nominate materials that are capable of sustaining long-term performance with the specified chemicals present in the fluid mediums (e.g. especially chlorides at elevated operating temperatures). Failure to control chemical levels in the mediums may result in premature corrosion of the plate pack and subsequent failure of the heat exchanger.

Note: Damage of the unit due to corrosion is excluded from the SPX warranty.

3.3: Fluid Particle Considerations

The particle size has a direct impact on the design/selection of strainers and pressing depth of plates

3.4: H₂S Content

For certain applications there is a special requirement to consider the content of H₂S (Hydrogen Sulphide). Often referred to as "sour service". The H₂S will impact the surface of the materials and cause a special type of corrosion. It is important to specify the H₂S content as these directly impact: material selection (plates and pressure vessel).

Health & Safety Warning



For "Oil and Gas" related applications the H₂S content is to be considered. H₂S is a strong poison. For this reason it is essential to choose the right material to avoid dangerous leakages and the possible impact on health and safety of operators/employees.

4: Design Conditions

To meet regulations on the safe design of the pressure vessel housing, it is required to specify the worst case, elevated, operating conditions (pressure & temperature). This will enable the design of the housing to be specified in compliance with the rules of the controlling regulations (e.g. P.E.D. or ASME, etc...).

Key Rules:

- Design pressure must be higher or min. equal to the operating pressure (common practice)
- Any requirements for a vacuum or partial vacuum must identified.

- The design temperature must also be stated as this has an impact on the strength calculation for the housing. Note for any material that is considered for the design there are maximum limiting temperatures and there are also limiting minimum temperatures. If no minimal was specified the design will assume 0 Degrees Celsius:

Pressure Limits



Under no circumstances must the unit be operated outside the specified design conditions stated on the name plate (also detailed in the drawing package)

4.1 Vacuum Operation of the Unit



The heat exchanger must be specifically designed to operate in a vacuum condition if this is to be part of normal operating conditions.

4.2 Accidental Vacuums

For normal designed units, there are operating conditions where an accidental vacuums may be created (e.g. through incorrect closure of valves) and the unit's headers may be forced to collapse through the formation of a vacuum.

If necessary a vacuum valve should be installed by the customer after analysis of the P&ID



<p>Your local contact:</p> <p>SPX Flow Technology 1200 W Ash St, Goldsboro, NC 27530, USA</p> <p>Phone: +1 919 735 4570 Fax: +1 919 581 1167</p>	<p>SPX Flow Technology Danmark A/S Platinvej 8, 6000 Kolding, Denmark</p> <p>Phone: +45 70 278 444 Fax: +45 70 278 445</p>
--	--



For more information about our worldwide locations, approvals, certifications, and local representatives, please visit www.spxft.com.

SPX Corporation reserves the right to incorporate our latest design and material changes without notice or obligation. Design features, materials of construction and dimensional data, as described in this bulletin, are provided for your information only and should not be relied upon unless confirmed in writing.