



Homogenizer

Rannie 315

Introduction

The Rannie 315 homogenizer, a positive-displacement triplex, reciprocating plunger pump, is fitted with an application-specific homogenizing valve assembly: single-stage with hydraulic actuation. As a high-pressure pump, this unit can be fitted with a relief valve.

The Rannie 315 homogenizer incorporates a durable slow-speed power end that reduces vibration and noise. Easy access to the hydraulic actuation system, lubrication oil and other auxiliary systems simplifies maintenance saving time and money. The Rannie 315 features a three-piece valve housing (ball and poppet style). As a standard the homogenizer is equipped with a Stellite XFD homogenizing valve.

Designed to simplify routine maintenance. Materials for plungers, packings, pump valves, valve seats and seals are custom-selected for your application. APV engineers will work with you to optimize the configuration for your specific application.



*Rannie three-piece
valve housing*

Standard Options

- Two-stage hydraulic valve actuation (HVA)
- Single-stage automatic hydraulic system (AHS)
- Two-stage automatic hydraulic system (AHS)
- Pulsation dampener(s) on inlet and outlet
- Aseptic cylinder design
- Electronic pressure transmitter (excl. display)
- High-pressure outlet
- Inlet pressure gauge
- Plunger lubrication control package
- Micro-Gap homogenizing valve
- Tungsten carbide homogenizing valve
- Square plunger seals and ceramic plungers
- External cooling fan/main motor
- Motor starter
- Control cabinet, stainless steel
- Thermostat/oil temperature

Special Options

- Ceramic plungers with U- or V-rings
- Explosion-proof design
- Electropolished wettables
- High-temperature design
- Flow switch - power end cooling

Rannie/Three-Piece Valve Housing Poppet and Ball Type Valves

Type	US -- max. cap./max. press.		Metric -- max.cap./max. press.	
	GPH	PSI	LPH	BAR
90.175	9245	3625	35000	250
70.175	5550	5800	21000	400
58.175	3750	8700	14200	600
50.175	2775	11600	10500	800
45.175	2115	14500	8000	1000

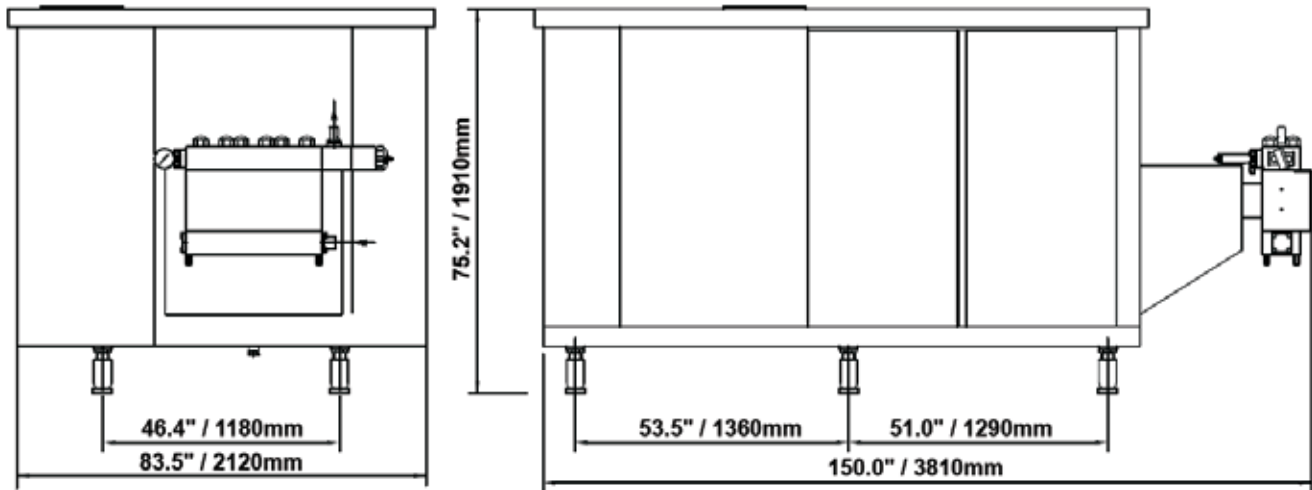

Dimensions (Single Stage)

Dimensions packed in a crate LxWxH (in.)	Dimensions packed in a crate LxWxH (cm)	Cubic measure m ³	Gross weight in a crate incl. motor
168 x 95.2 x 92	420 x 238 x 230	23.0	19,180 lb./8,700 kg

APV, An SPX Brand
 Phone: (888) 278-4321
 Email: answers.us@apv.com

For more information about our worldwide locations, approvals, certifications, and local representatives, please visit www.apv.com.

SPX Corporation reserves the right to incorporate our latest design and material changes without notice or obligation.

Design features, materials of construction and dimensional data, as described in this bulletin, are provided for your information only and should not be relied upon unless confirmed in writing.

Issued: 08/2008 3027-02-08-2008-US

Copyright © 2002 2008 SPX Corporation



WHERE IDEAS MEET INDUSTRY