

Flex-Mix[™] Processor



Application

Flex-Mix™ Processor is a highly efficient batch processing unit, developed to handle demanding mixing applications including high viscous liquids, emulsification and additional particulates.

Typical applications includes:

- Process cheese/cheese spreads
- Soups and sauces with particulates
- Fruit preparations
- Ice cream ripple
- Slurries and gum dispersion
- Mayonnaise, sauces and ketchup
- Cream, ointments and hand lotion

Capacity

Batch production: 250, 500, 1000, 2000, 3000 litres

- Capacity per hour: up to 20,000 litres depending on product complexity

Operation

Flex-Mix™ Processor is an inclined tank with a bottom mounted high shear mixer. This mixer partly functions as an axial agitator and/or partly as an in-line mixer. It creates an axial flow, which is re-circulated in the tank by means of the surrounding mixer chamber and/or a positive booster pump, which is used to bypass and re-circulate the flow over the tank. The bypass flow is returned into the tank and the inclined tank ensures that no liquid rotation (forced vortex) will be created in the tank.

The tank is also equipped with a slow rotating agitator ensuring a careful stirring and homogeneous mixing of particulated products simultaneously with the creation of an axial flow, which feeds the bottom impeller. When mounted with scraper blades, the agitator ensures that the product does not burn and stick to the tank wall during indirect heating (tank with cooling/heating jacket). In case the product is heated, the tank can be put under pressure.

By means of vacuum powder is transported into the tank through a special powder inlet valve. The mixture of powder/air is led directly into the liquid below the liquid surface. Air/gas is removed by the vacuum pump. The large free liquid surface gives an effective deaeration of the product. Unlike traditional mixing that general incorporate air during mixing. This will help to reduce oxidation, improve product quality and consistency. Addition of powders or other dry matter can also take place through the manway placed in the top of the tank.

General

- Sanitary design for CIP cleaning. Fully drainable for improved hygiene and minimal waste of product
- Integrated Flex-Mix™ Processor Tank, Flex-Mix™ Bottom Mixer and Flex-Mix™ Agitator
- Available with integrated recirculation booster pump
- Available with integrated vacuum system.
- Integrated CIP system
- Available with integrated Flex-Mix™ Processor PC/PLC

Control System

- Skid mounted
- Available with powder funnel, open as well as closed for CIP cleaning
- Seal material in EPDM or FPM (Viton), FDA approved quality
- All parts in contact with the product are made of acid proof stainless steel AISI 316L / DIN1.4404

Flex-Mix™ Processor tank design

- Cylindrical, inclined tank in the following sizes: 250, 500, 1000, 2000, 3000 litres
- Internal/external tank surfaces in 2B finish with polished welds. Surfaces in contact with the product: Ra < 1 µm
- Available with heating/cooling jacket on tank wall and/or with insulation on outer shell
- Available with steam injection valves for direct product heating
- Top mounted manway cover, available with safety lock
- Top mounted vent/safety valve
- Top mounted sight glass with light
- With 4 CIP-inlet pipes, ø25 mm, with rotating spray ball
- One or more product inlets for liquids
- One or more powder inlet valves
- Available with level switches and/or load cells

Flex-Mix™ Bottom Mixer

- In two sizes with rotor diameters: ø250 and ø350 mm
- Available with high shear impeller and stator ring
- Directly coupled motor (closed coupled design). Fully encapsulated, IEC or NEMA, IP55, covered by stainless steel jacket, 4 poles
- Double mechanical shaft seal for water flush made of Silicium/Carbon alternatively of Silicium/Silicium seal ring material
- Available with the following axial units: Flow inducer propeller, premix blade, rotating knife

Flex-Mix™ Agitator

- Slow axial flow type agitator, coupled with gear and fully encapsulated electric motor, IEC or NEMA, IP55
- Double mechanical shaft seal for water flush made of Silicium/Carbon alternatively of Silicium/Silicium seal ring material
- Available with scraper blades against tank shell for removal of product film and improved heating or cooling

Recirculation system

- APV DW 4 positive pump with gear and totally encapsulated electric motor, IEC or NEMA
- With tubular heat exchanger on the recirculation pipe

Vacuum system

- Liquid ring vacuum pump in stainless steel/plastic resistant to CIP liquids
- Directly coupled motor (closed coupled design) Totally encapsulated, IEC or NEMA, IP55, 4 poles
- With liquid separator for re-use of service water
- With regulation valve for vacuum level

Flex-Mix™ Processor PLC/PC Control System

- Available with the following control panel systems:
 - PLC-Relay Batch Control
 - PLC/PC Batch Control
 - PLC/PC Semi-Continues Control
- PLC/PC Continuous Control
- Available with Wonderware or Siemens operation panels
- With MCC (Motor Control Centre) with and without frequency inverter

TECHNICAL DATA											
Type Flex-Mix™	Tank		Bottom Mixer			Vacuum Pump	Valves	Agitator		Booster Pump	
	Tank volume	Pressure rating	Inline mixer size	Motor @ 1500 rpm		Data @ 500 mbar	Min./Max. air pressure	Type		Type	
				Size Type IEC	Power	Air capacity / power (@ 50 Hz)		Axial @ 24 rpm	Helical	DW4-125-5 @ 1000cP	
	L	Bar			Kw		Bar	kW		m ³ /h	kW
Processor-250-250	250	Full vacuum to 3	Ø250	180	18,5	150 m ³ /h / 4 kW	6 / 8	0.75		30	7.5
				200	22						
Processor-500-250	500		Ø250	180	18,5			1.1		30	7.5
				200	22			2.2			
Processor-1000-250	1000		Ø250	180	18,5			2.2	3.0	60	11
				200	22						
Processor-1000-350			Ø350	225	30			4.0	5.5	60	11
				37	7.5						
Processor-2000-250	2000	Ø250	200	30	4.0	5.5	60	11			
			37	7.5							
Processor-2000-350		Ø350	225	75	4.0	5.5	60	11			
			110	7.5							
Processor-3000-350	3000	Ø350	225	75	4.0	5.5	60	11			
				110	7.5						

DIMENSIONS - APPROX. MM				
Type Flex-Mix™	A	B	C	Shipping volume (m ³)
Processor-250-250	2015	2430	1340	7
Processor-500-250	2320	2485	1580	11
Processor-1000-250	2680	3025	1850	15
Processor-1000-350				
Processor-2000-250	3075	3350	2110	23
Processor-2000-350				
Processor-3000-350	3380	3610	2470	34

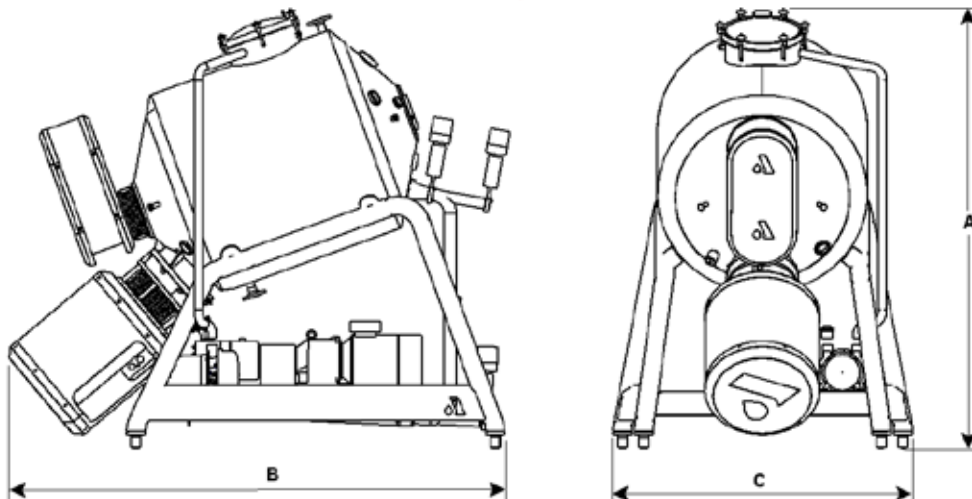



Your local contact:



SPX Flow Technology
Pasteursvej
8600 Silkeborg
Phone: +45 70 278 278 Fax: +45 70 278 330
www.apv.com
www.spxft.com

For more information about our worldwide locations, approvals, certifications, and local representatives, please visit www.apv.com.

SPX Corporation reserves the right to incorporate our latest design and material changes without notice or obligation. Design features, materials of construction and dimensional data, as described in this bulletin, are provided for your information only and should not be relied upon unless confirmed in writing.

Issued: 10/2010 6208-04-10-2010-GB

Copyright © 2009 SPX Corporation