



DELTA MS4/MSP4

Aseptic Single Seat Valve

Description

The DELTA MS4 and MSP4 aseptic single seat valve series from APV is designed for applications in the food, beverage, dairy, pharmaceutical and chemical industries.

The housing is made of high resistant stainless steel AISI 316L with a product wetted surface finish of Ra 0,8 µm. All other non-product wetted stainless steel parts is made of stainless steel AISI 304.

The MSP4 valve has been developed especially for applications where elastomers are not acceptable in product wetted areas.

The DELTA MS4 and MSP4 valves are available in shut-off and change over design. It is also available as tank outlet valve.

Operating principle

The single layer diaphragm of the DELTA MS4 is made of TFM. The "diaphragm shaft" of the DELTA MSP4 valve is a single piece unit and consists of the diaphragm, shaft and disc made from PTFE TFM. The opening and closing of the valve is performed either by a pneumatic actuator or manually by means of a crank.

During opening and closing, the diaphragm is continuously supported by a unique fan support system, which relieves process pressure on the diaphragm, thus protecting it against overstress and/or pressure spikes. This system significantly increases diaphragm reliability and lifetime.

Fan support system

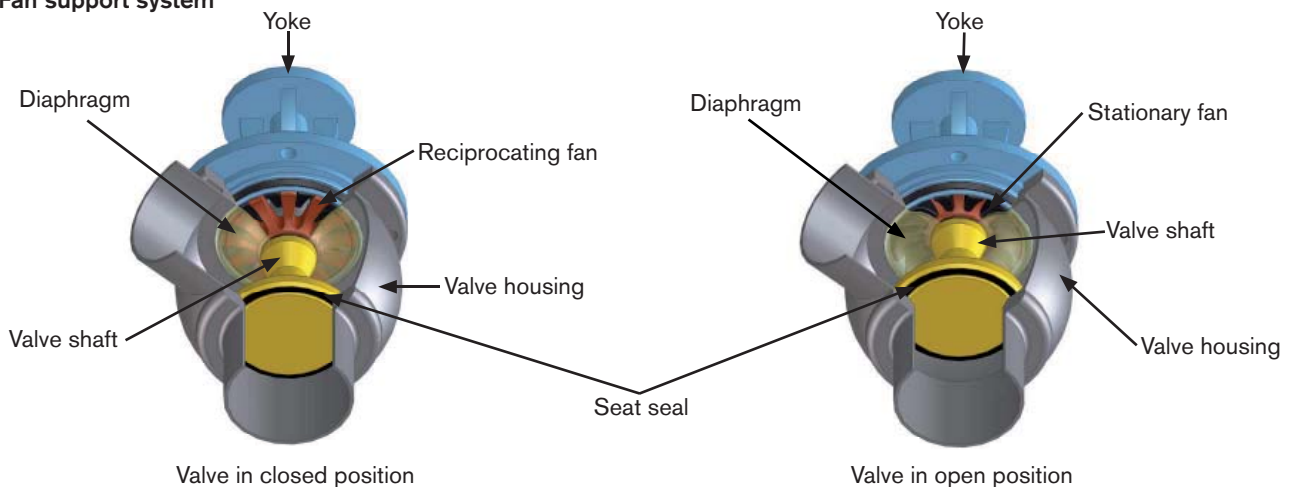

Approvals

Following approvals are available.
Diaphragm shaft MSP4 and diaphragm: USP class Class VI.
Valve: EHEDG and 3A.

Options

The DELTA MS4 and MSP4 is available with a proximity switch holder (standard) or a control unit (option) to control open/closed valve position.

Product specification

Sizes	DN25, DN40, DN50, DN65, DN80, DN100 1", 1,5", 2", 2,5", 3", 4"
Housing configuration	MS4: MS41 (L), MS42 (T), MSE41 (KLL), MSE42 (KTL), MSE43 (KLT), MSE44 (KTT), MSES45 (LLS), MST41 (L), MST42 (T) MSP4 : MSP41 (L), MSP42 (T), MSPE41 (KLL), MSPE42 (KTL), MSPE43 (KLT), MSPE44 (KTT), MSPT 41 (L), MSPT42 (T)
Product pressure	Max. 10 bar
Continuous operating temperature	Max. 135°C
Sterilisation temperature	140°C EPDM, HNBR (short term)
Control air pressure	Min. 6 bar, max. 8 bar
Product wetted parts	AISI 316 L (1.4404)
Non product wetted parts	AISI 304 (1.4301)
Seal material	Seat seal: EPDM, HNBR, FPM and VMQ Diaphragm + Diaphragm shaft MSP: TFM

Dimension sketches

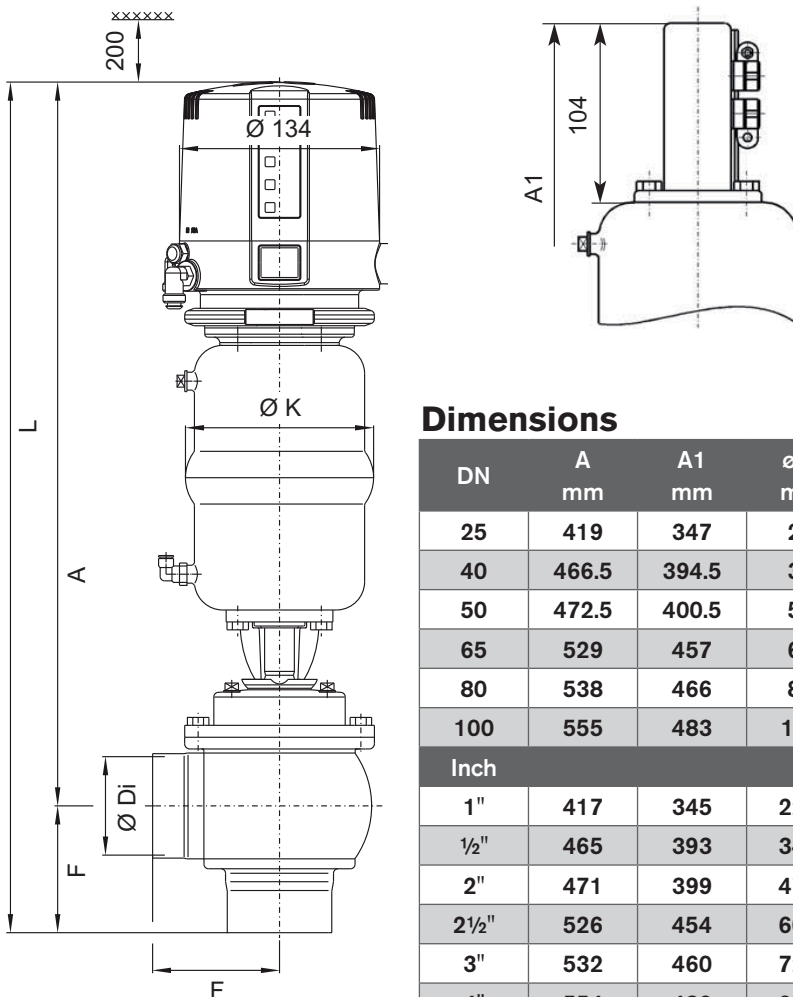

Dimensions

DN	A mm	A1 mm	øDi mm	F mm	øK mm	L mm	Weight in kg
25	419	347	26	50	86	469	4.2
40	466.5	394.5	38	67	126	533.5	7.1
50	472.5	400.5	50	72	126	544.5	7.1
65	529	457	66	85	189	614	7.9
80	538	466	81	98	189	636	14.2
100	555	483	100	111	189	666	15.2
Inch							
1"	417	345	22.2	50	86	467	4.2
1/2"	465	393	34.9	67	126	532	7.1
2"	471	399	47.6	72	126	543	7.1
2 1/2"	526	454	60.3	85	189	611	7.9
3"	532	460	72.9	100	189	632	14.5
4"	554	482	97.6	111	189	665	15.2

DELTA MS41 & MS42 with CU4 Control Unit

APV, An SPX Brand, Zechenstrasse 49, D-59425 Unna
Phone: +49(0)2303/108-0 Fax: +49(0)2303/108-210

For more information about our worldwide locations, approvals, certifications, and local representatives, please visit www.apv.com.

SPX Corporation reserves the right to incorporate our latest design and material changes without notice or obligation. Design features, materials of construction and dimensional data, as described in this bulletin, are provided for your information only and should not be relied upon unless confirmed in writing.

Issued: 09/2009 8022-03-09-2009-GB

Copyright © 2008, 2009 SPX Corporation

SPX
WHERE IDEAS MEET INDUSTRY