



Brine Reclamation Process

The APV Brine Reclamation system is a fully automated process that enables the re-use of brine solutions in many meat curing processes.

Brine spray cabinets and soak tanks are the standard curing and flavoring methods in many meat processing facilities. The initial brine cost and disposal can be significant expenses in the process economics. APV has developed a NEW method for recovering diluted brine; allowing reuse of the brine, thereby minimizing the disposal costs of spent brine.

The APV Brine Reclamation Process is the NEW solution to the OLD problem.

The APV brine recovery design differs from old brine recovery methods in several ways:

- It does not employ components with high cost consumable parts.
- The automation program requires little operator involvement in all stages of operation; startup, feed forward, CIP, and shutdown.
- The APV process is directly incorporated into existing brine spray systems or tanks; automatically removing used brine and returning refreshed brine as needed to the brine spray, or tank systems.

The Process Economics

The APV Brine system reduces brine usage by a minimal factor of 10 to 1 and as much as 20 to 1.

- Instead of continually using “fresh brine”, the APV Brine System uses a small amount of “make-up” brine during production.
- The disposal costs of “spent brine” are reduced by the same ratio as the “fresh brine” reduction; 10 to 1 or as much as 20 to 1.

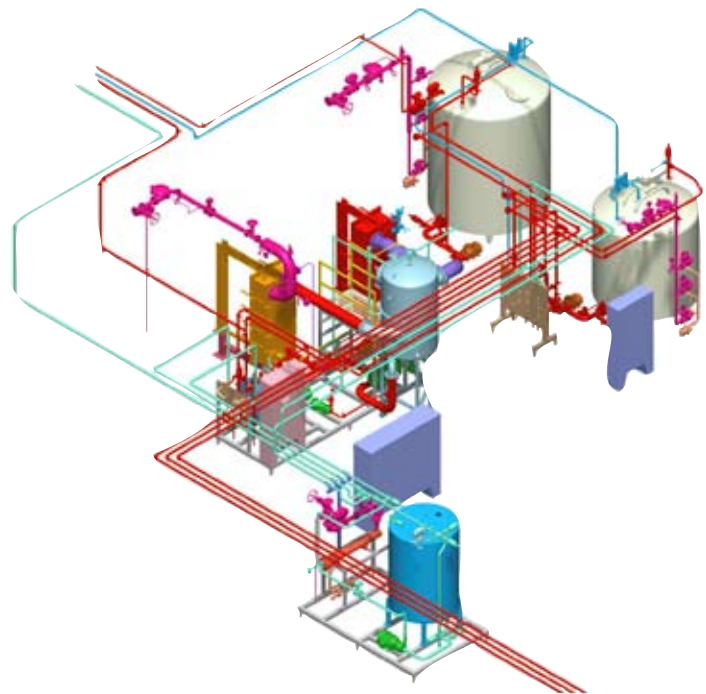

Functionality

The brine is removed from the meat processing equipment based on the density of the brine. APV takes control of the fluid once it is removed from the meat processing equipment. Diluted brine is sent to an accumulation tank to develop an inventory of fluid. Once a “buffer” level of fluid is achieved, the diluted brine is introduced to an APV Plate Evaporator. The APV evaporator controls the flow of fluid to the evaporator and the discharge density of the brine solution. The evaporator discharge is then fed to a brine tank. Once an acceptable level of fluid is reached in the brine tank, the “reclaimed” brine is pumped back to the meat processing equipment. The process can be simplified if a batch-style process is preferred.

The needs of each processing facility vary. APV design engineers will accommodate the specific plant requirements for proper operation and control. Pasteurization of the brine is easily accomplished in the preheat scheme of the evaporator or as a stand-alone unit. Feed filtration requirements are also incorporated as part of the evaporator feed.

Automation

The APV Automation program for the Brine Reclamation Process is a simple “sequential” design.

The main control is managed at a central workstation. APV will “handshake” signals between the brine spray or tank systems, this allows for a simplified umbrella control scheme that will keep existing controls intact as designed. The fluid levels of 3rd party brine spray or tank systems are the only parameter that APV will need to control.

The sequential program employs a custom-designed computer control scheme that simplifies the operation to automatic start and stop control. The operator will only have to press start and the program will take control of the entire system. Pre-programmed alarms and interlocks protect the personnel and equipment. Once started, the operator can press the CIP button to go into a cleaning mode. A shutdown button will safely bring the system to a complete stop.

APV supports several platforms of automation design.

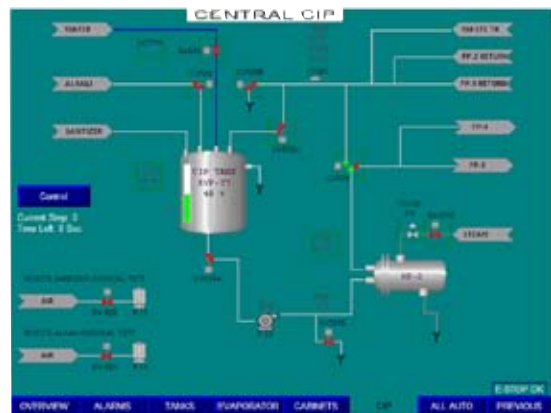
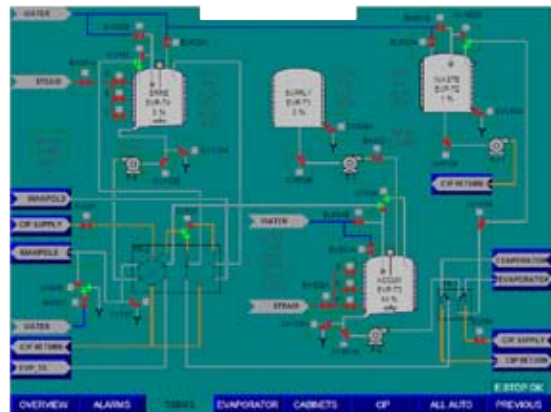
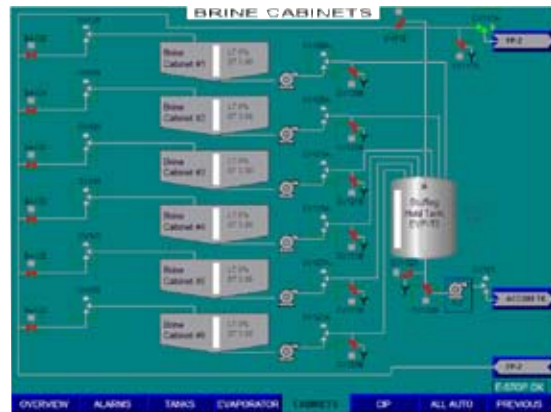

APV, An SPX Brand
105 CrossPoint Parkway
Getzville, NY 14068
Phone: (800) 207-2708 Fax: (716) 692-1715
Email: answers.us@apv.com

For more information about our worldwide locations, approvals, certifications, and local representatives, please visit www.apv.com.

SPX Corporation reserves the right to incorporate our latest design and material changes without notice or obligation. Design features, materials of construction and dimensional data, as described in this bulletin, are provided for your information only and should not be relied upon unless confirmed in writing.

Issued: 08/2008 10002-01-08-2008-US

Copyright © 2008 SPX Corporation

SPX
WHERE IDEAS MEET INDUSTRY