



APV CIP MINI System



The APV CIP MINI System is a single-use CIP system which operates on the principle of preparing a fresh solution for each wash and discarding afterwards. This is in contrast to a reclaim-type CIP system, where a washing solution is made up in a tank, and then used over and over again for successive washing cycles, only being topped up to maintain its strength

The APV CIP MINI System is ideally suited to applications such as the following:

These include:

- High specification cleaning duties, where there must be no possibility of contamination from one washing cycle to the next, necessitating makeup of a fresh solution for every wash
- Cleaning of heavily-soiled equipment, where at the end of the wash, the washing solution is so contaminated that it must be discarded (for example - CIP of road tankers transporting molasses)
- Applications calling for infrequent washing of a limited number of circuits, where the cost of a classic reclaim CIP plant cannot be justified (for example a small production plant or a section of plant remote from the main plant)

The APV CIP MINI System is designed to accommodate an optional rinse water recovery tank,

where the water used for the final rinse is reclaimed to use for the first rinse of the next wash, thus saving considerably on water and effluent. An additional option provides for a separate rinse water tank which can be used in high-spec applications (for example pharma or bio-tech) to provide high purity final rinse water.

The optional tanks are added in a compact modular skid mounted design.

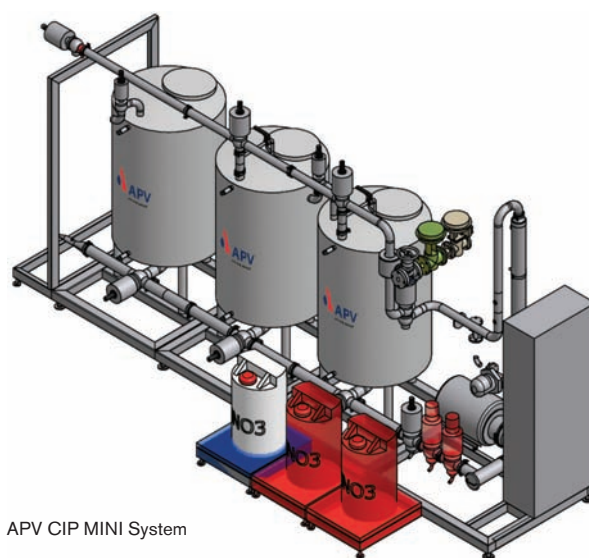

APV CIP MINI System

Equipment sizing (production capacities)

CIP MINI SIZING INFORMATION						
MODEL	FLOW RATE		TANK SIZE		TANK DROP	DISCHARGE & RETURN
	LPH	GPM (US)	LITRES	GALLONS (US)	O.D. INCHES	O.D. INCHES
MINI 1.5	8,000	35	400	106	2	1.5
MINI 2	12,500	55	600	158	2.5	2
MINI 2.5	20,000	88	850	224	3	2.5
MINI 3	36,000	158	1,250	330	4	3

Production capacities

CIP MINI WASHING DUTY SECTION				
MODEL	PIPELINE WASH (2M/S)		TANK WASH **	
	MAX. PIPE DIA. (IN)	MAX. PIPE LENGTH (M)	TANK SIZE (L)	TANK SIZE (GALLONS US)
MINI 1.5	1.5	200	2,000 - 10,000	500 - 2,500
MINI 2	2	150	5,000 - 25,000	1,300 - 6,500
MINI 2.5	2.5	150	10,000 - 50,000	2,500 - 12,500
MINI 3	3	150	20,000 - 100,000	5,000 - 25,000

** INDICATIVE ONLY - sizing should be based on specific tank spray device requirement

Specification

- Sanitary, Single Use CIP w/o Recovery, Single Tank
- 4 Standard Volumetric Sizes, (400, 600, 850 & 1,250 Liters)
- 4 Standard Circulation Rates, (8,000, 12,500, 20,000 & 36,000 l/h)
- Frame Mounted Tank, Equipment & Panel (Stainless Steel)
- CIP Solution Heating by APV ParaTube, Stainless Steel Shell & Tube, 12°C per Pass
- Stainless Steel Steam Control w/Float Trap
- Single Chemical Delivery System (Pump, Injector & Valves)
- Pneumatic, Single-Seat Rising Stem Sanitary Valves Std
- Control Tops w/Dual Feedbacks & Solenoids on APV valves and pilot air sv's on service valves
- CIP Supply Temperature transmitter
- CIP Return Temperature transmitter
- EHEDG APV Process Equipment (Valves, Pumps & Fittings)
- EHEDG Sanitary Endress & Hauser Instrumentation (Temperature & Level)
- Std. IP65 Stainless Steel, High & Low Voltage Panel
- Integral, IP65 Panel Mounted - Siemens Simatic S7-315-2 PN/DP
- Siemens MP277 10" HMI Panel, mounted in the door of the Control Panel
- Std. 3 Step CIP (Prerinse, Alkali Circulation and Postrinse)
- IEC Electrical Std. (230/460V, 3 Phase, 50 Hertz)

Options

- Construction to 3A standards for US market
- Sanitary, Secondary Rinse Water Tank (Two Tank)
- Sanitary, Recovery Water Tank Design (Two Tank)
- Sanitary, APV Double Seat Mixproof Valves on tank suction
- Insulated (Urethane) & Stainless Steel Jacketed Tank(s)

- Sprayball , CIP Tank
- Dual Chemical Delivery System (Acid & Alkali)
- Triple Chemical Delivery System (Acid, Alkali and Sanitizer)
- Air Blow Out End of Cycle Purge
- CIP Supply Line Strainer
- CIP Supply Flow Transmitter (Magnetic)
- CIP Supply Pressure Transmitter
- CIP Return Pump
- CIP Return Strainer
- CIP Return Conductivity Transmitter
- CIP Return Flow Switch
- Steam Supply/PRV Station (PRV, Inlet Strainer, High/Low Pressure Gauges, Manual Inlet/Outlet Stop Valves).
- Allen-Bradley CompactLogix PLC and Rockwell PanelView 600 Touch HMI Panel
- NEMA Electrical standard (230/460 V, 3 Phase, 60 Hertz)
- Ethernet PLC Interface Module
- AC Variable Speed Drive (Danfoss or Allen Bradley Powerflex) on CIP Supply Pump
- Motor Starter for CIP Return Pump
- High-Efficiency CIP Return Pump, APV Type WI+
- 5 Step CIP (Prerinse, Alkali Circulation, Postrinse, Acid Circulation, Postrinse)
- 7 Step CIP (Prerinse, Alkali Circulation, Postrinse, Acid Circulation, Postrinse, Sanitize, Rinse)

Cost saving options

- Remove Heating Set (Circulation Only)
- Substitute APV ParaTube Tubular Heat Exchanger for Plate Heat Exchanger
- Substitute Sanitary Rising Stem Valves for Butterfly Valves
- Substitute Independent PLC Control with remote I/O
- Remove Motor Starters

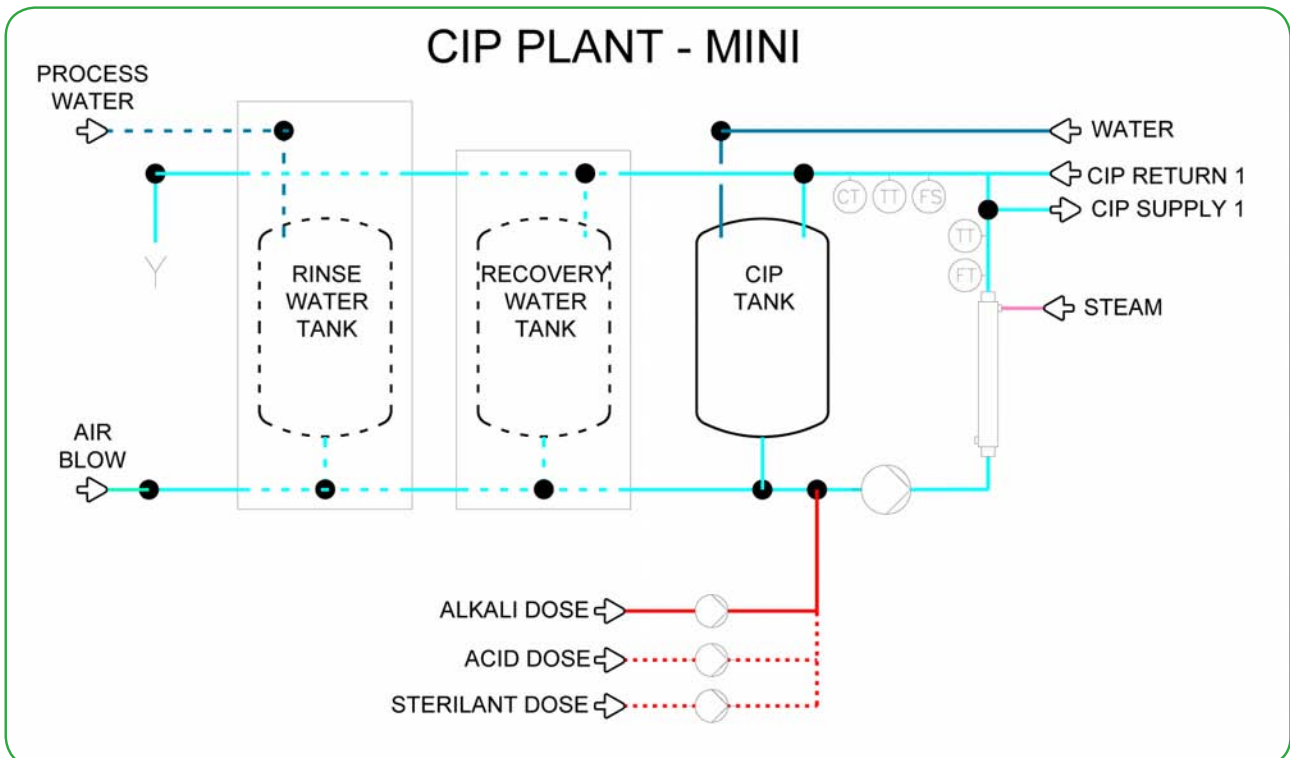



Your local contact:



SPX Flow Technology
Pasteursvej
DK-8600 Silkeborg, Denmark
Phone: +45 70 278 278 Fax: +45 70 278 330
www.apv.com
www.spxft.com

For more information about our worldwide locations, approvals, certifications, and local representatives, please visit www.apv.com.

SPX Corporation reserves the right to incorporate our latest design and material changes without notice or obligation. Design features, materials of construction and dimensional data, as described in this bulletin, are provided for your information only and should not be relied upon unless confirmed in writing.

Issued: 09/2010 10012-03-09-2010-GB

Copyright © 2010 SPX Corporation