

APV CIP MIDI System

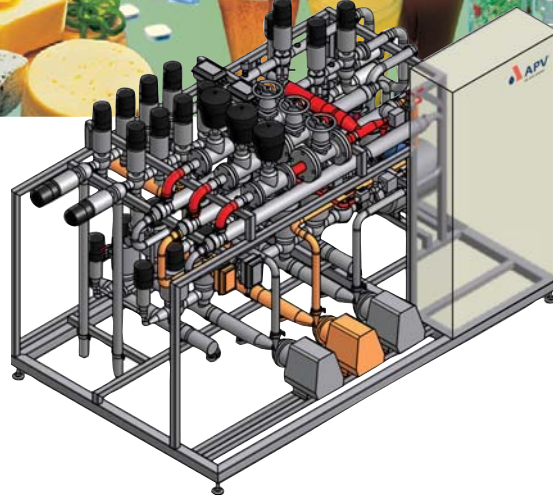

The APV CIP MIDI system is a fully automatic, self-contained system. It comprises a complete set of equipment for CIP, including, for example, tanks for water, acid and caustic soda, pumps, tubular and/or plate heat exchangers, valves and instrumentation such as conductivity and flow transmitters.

All of the process components are mounted on the skid independently from the tanks giving flexibility in equipment layout on site.

The APV CIP program covers the complete cycle. Detergent or water selection, detergent concentrations and cycle temperatures and times are fully controlled. The CIP MIDI has some features which make it ideally suited for certain applications:

- Compact design
- 1-4 forward lines
- Several options
- PLC controlled
- Fully automatic

The APV CIP MIDI is intended for small to medium CIP applications, and will cater for the following capacities and sizes with up to a maximum of 2 CIP circuits per CIP set:

Specification

- Sanitary, Reclaim CIP , Multi-Compartment Horizontal Tank (Alkali, Acid)
- Rinse water by direct supply
- One Circuit or Two Circuits
- 5 Standard Volumetric Sizes, (1000, 1500, 2000, 3000 and 4000 Liters)
- 3 Standard Circulation Rates, (8,000, 12,500, 20,000 LPH)
- Frame Mounted Equipment & Panel (Stainless Steel)
- Free-standing horizontal multi-compartment tank
- CIP Solution Heating in-tank by APV ParaTube, Stainless Steel Shell & Tube, 12°C per Pass
- Stainless Steel Steam Control w/Float Trap
- Pneumatic, Single-Seat Rising Stem Sanitary Valves Std.
- Control Tops w/Dual Feedbacks & Solenoids on APV valves and pilot air sv's on service valves
- EHEDG APV Process Equipment (Valves, Pumps & Fittings)
- EHEDG Sanitary Endress & Hauser Instrumentation (Temperature & Level)
- CIP Supply Flow Transmitter (Magnetic)
- AC Variable Speed Drive (Danfoss or Allen Bradley Powerflex) on CIP Supply Pump
- CIP Return Conductivity Transmitter
- CIP Return Flow Switch
- Std. IP65 Stainless Steel, High & Low Voltage Panel
- Integral, IP65 Panel Mounted - Siemens Simatic S7-315-2 PN/DP Siemens MP277 10" HMI Panel, mounted in the door of the Control Panel
- Std. 3 Step CIP (Prerinse, Alkali Circulation and Postrinse)
- IEC Electrical Std. (230/460V, 3 Phase, 50 Hertz)

Equipment sizing (production capacities)

CIP MIDI SIZING INFORMATION							
TANK SIZE							
FLOW RATE		ONE CIP CIRCUIT		TWO CIP CIRCUITS		PUMP SUCTION	DISCHARGE & RETURN
LPH	GPM (US)	LITRES	GALLONS (US)	LITRES	GALLONS (US)	O.D. INCHES	O.D. INCHES
8,000	35	1,000	260	2,000	520	2	1.5
12,500	55	1,500	390	3,000	780	2.5	2
20,000	88	2,000	520	4,000	1,040	3	2.5

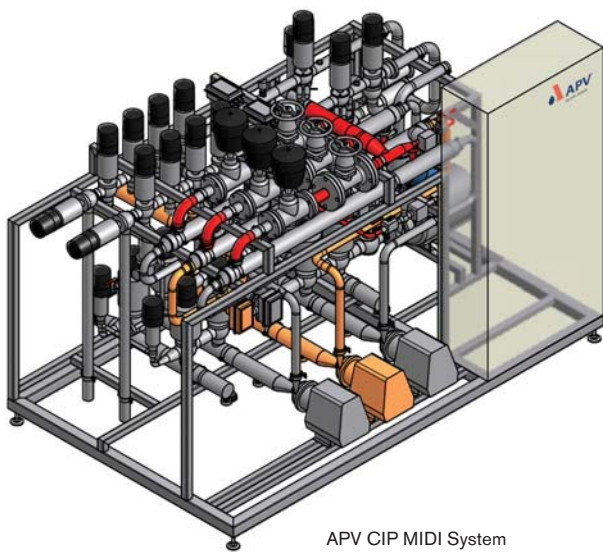

Options

- Sanitary, Rinse Water compartment
- Sanitary, Hot Rinse Water compartment
- Sanitary, Recovery Water compartment
- Sanitary, APV Double Seat Mix-Proof Valves on CIP outlet lines
- Insulated (Urethane) & Stainless Steel Jacketed Tank (s)
- Air Blow Out End of Cycle Purge
- CIP Supply Line Strainer
- CIP Supply Pressure Transmitter
- CIP Return Pump
- CIP Return Strainer
- CIP Return Temperature transmitter
- Steam Supply/PRV Station (Stainless Steel PRV, Inlet Strainer, High/Low Pressure Gauges, Manual Inlet/Outlet Stop Valves).
- Condensate Pressure Return Pump (Stainless Steel Pump & Valves)
- Allen-Bradley CompactLogix PLC and Rockwell PanelView 600 Touch HMI Panel
- NEMA Electrical standard (230/460 V, 3 Phase, 60 Hertz)
- Ethernet PLC Interface Module
- Motor Starter for CIP Return Pump(s)
- High-Efficiency CIP Return Pump(s), APV Type WI+
- 7 Step CIP (Pre-rinse, Alkali Circulation, Post rinse, Acid Circulation, Post rinse, Sanitize, Rinse)

Cost saving options

- Substitute Sanitary Rising Stem Valves for Butterfly Valves
- Substitute Independent PLC Control with remote I/O
- Remove Motor Starters

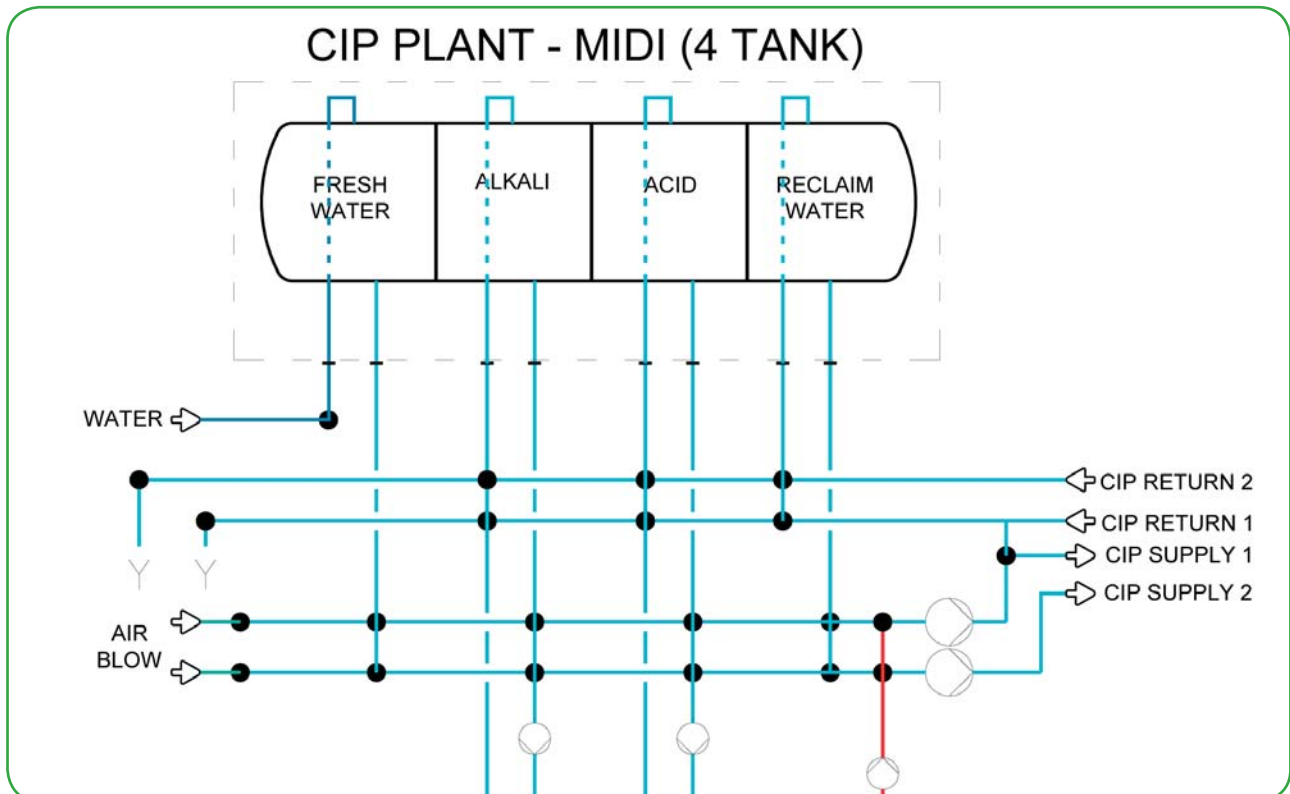



Your local contact:



SPX Flow Technology
Pasteursvej
DK-8600 Silkeborg, Denmark
Phone: +45 70 278 278 Fax: +45 70 278 330
www.apv.com
www.spxft.com

For more information about our worldwide locations, approvals, certifications, and local representatives, please visit www.apv.com.

SPX Corporation reserves the right to incorporate our latest design and material changes without notice or obligation. Design features, materials of construction and dimensional data, as described in this bulletin, are provided for your information only and should not be relied upon unless confirmed in writing.

Issued: 09/2010 10011-03-09-2010-GB

Copyright © 2010 SPX Corporation