



# Homogenizer

## Rannie 5 /Gaulin 5

### Introduction

The Rannie 5 / Gaulin 5 homogenizer, a positive displacement triplex, reciprocating plunger pump, is fitted with an application-specific homogenizing valve assembly: single-stage with manual actuation. As a high-pressure pump, this unit can be fitted with a relief valve.



*Rannie three-piece valve housing*

The Rannie 5 / Gaulin 5 homogenizer incorporates a durable slow-speed power end that reduces vibration and noise. Easy access to the lubrication oil and other auxiliary systems simplifies maintenance saving time and money. Liquid end options include a three-piece valve housing (Rannie) and a mono-block design (Gaulin) (ball and poppet style). As a standard the homogenizer is equipped with a Stellite XFD homogenizing valve.



*Gaulin mono-block design*

Design features of both the Rannie and Gaulin simplify routine maintenance.

Materials for plungers, packings, pump valves, valve seats and seals are custom-selected for your application. APV engineers will work with you to optimize the configuration for your specific application.

### Standard Options

- Two-stage manual
- Single-stage hydraulic valve actuation (HVA)
- Two-stage hydraulic valve actuation (HVA)
- Single-stage automatic hydraulic system (AHS)
- Two-stage automatic hydraulic system (AHS)
- Aseptic cylinder design
- Electronic pressure transmitter excl. display
- High-pressure outlet
- Inlet pressure gauge
- Plunger lubrication control package
- Tungsten carbide homogenizing valve
- Square plunger seals and ceramic plungers (Rannie valve housing only)
- External cooling fan/main motor
- Motor starter

### Special Options

- Acid-proof cylinder (Gaulin valve housing only)
- Ceramic plungers with U- or V-rings \*
- Explosion-proof design
- Electropolished wettables
- High-temperature design

\* For pressures above 600 bar the plungers and the type of homogenizing valve may change.

## Rannie/Three-Piece Valve Housing Poppet and Ball Type Valves

Type	U.S. max. cap./max. press.		Metric max.cap./max. press.	
	GPH	PSI	LPH	BAR
25.38	240	2900	900	200
22.38	185	3625	700	250
20.38	150	4300	570	300
18.38	120	5800	450	400
14.38	65	8700	250	600
12.38	34	11600	130	800
10.38	21	14500	80	1000

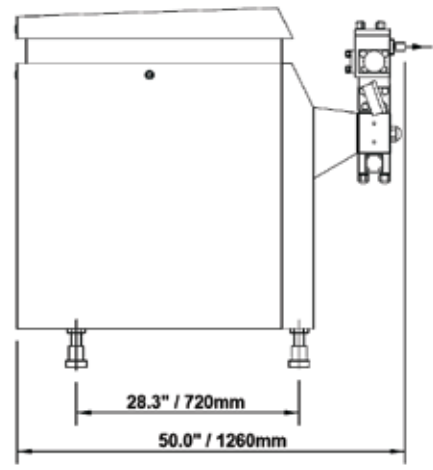
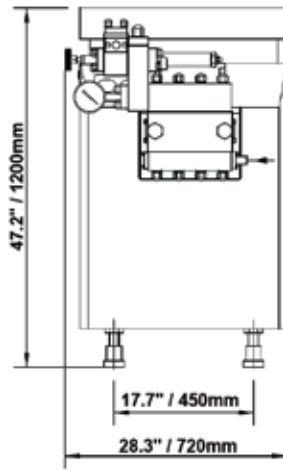

## Gaulin/Mono-Block Design

Type	U.S. max. cap./max. press.		Metric max.cap./max. press.	
	GPH	PSI	LPH	BAR
<b>Poppet type valves</b>				
3.0	225	3000	850	210
<b>Ball type valves</b>				
3.0	190	3000	720	210
4.3	130	4300	500	300
5.8	105	5800	400	400
8.7	50	8700	180	600

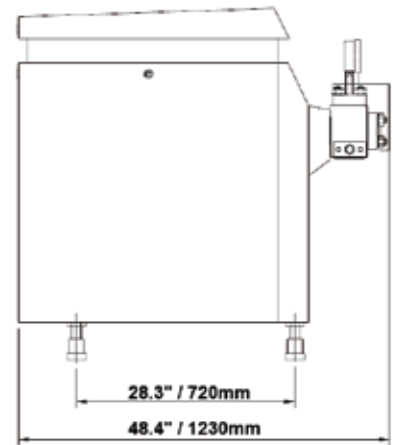
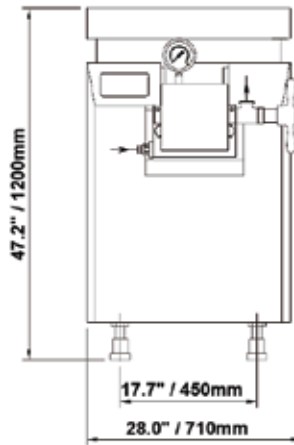

## Dimensions (Single Stage)

Dimensions packed in a crate LxWxH (in.)	Dimensions packed in a crate LxWxH (cm)	Cubic measure m <sup>3</sup>	Gross weight in a crate, incl. motor
51 x 34 x 59	130 x 85 x 150	1.6	1,543 lb./700 kg

APV, An SPX Brand  
Phone: (888) 278-4321  
Email: [answers.us@apv.com](mailto:answers.us@apv.com)

For more information about our worldwide locations, approvals, certifications, and local representatives, please visit [www.apv.com](http://www.apv.com).

SPX Corporation reserves the right to incorporate our latest design and material changes without notice or obligation. Design features, materials of construction and dimensional data, as described in this bulletin, are provided for your information only and should not be relied upon unless confirmed in writing.

Issued: 08/2008 3020-02-08-2008 Copyright © 2002, 2008 SPX Corporation

**SPX**  
WHERE IDEAS MEET INDUSTRY