



Homogenizer

Rannie 37 /Gaulin 37

Introduction

The Rannie 37 / Gaulin 37 homogenizer, a positive displacement triplex, reciprocating plunger pump, is fitted with an application-specific homogenizing valve assembly: single-stage with hydraulic actuation. As a high-pressure pump, this unit can be fitted with a relief valve.

The Rannie 37 / Gaulin 37 homogenizer incorporates a durable slow-speed power end that reduces vibration and noise. Easy access to the hydraulic actuation system, lubrication oil and other auxiliary systems simplifies maintenance saving time and money. Liquid end options include a three-piece valve housing (Rannie) and a mono-block design (Gaulin) (ball and poppet style). As a standard the homogenizer is equipped with a Stellite XFD homogenizing valve.

Design features of both the Rannie and Gaulin simplify routine maintenance. Materials for plungers, packings, pump valves, valve seats and seals are custom-selected for your application. APV engineers will work with you to optimize the configuration for your specific application.



Rannie three-piece valve housing



Gaulin mono-block design

Standard Options

- Two-stage hydraulic valve actuation (HVA)
- Single-stage automatic hydraulic system (AHS)
- Two-stage automatic hydraulic system (AHS)
- Pulsation dampener(s) on inlet and outlet
- Aseptic cylinder design
- Electronic pressure transmitter excl. display
- High-pressure outlet
- Inlet pressure gauge
- Plunger lubrication control package
- Tungsten carbide homogenizing valve
- Square plunger seals and ceramic plungers (Rannie valve housing only)
- External cooling fan/main motor
- Motor starter
- Control cabinet, stainless steel
- Thermostat/oil temperature

Special Options

- Acid-proof cylinder (Gaulin valve housing only)
- Ceramic plungers with U- or V-rings
- Explosion-proof design
- Electropolished wettables
- High-temperature design
- Flow switch - power end cooling

Rannie/Three-Piece Valve Housing Poppet and Ball Type Valves

Type	US max. cap./max. press.		Metric max.cap./max. press.	
	GPH	PSI	LPH	BAR
60.81	2170	2175	8200	150
50.81	1530	2900	5800	200
45.81	1240	3625	4700	250
42.81	1085	4300	4100	300
35.81	740	5800	2800	400
30.81	530	8700	2000	600
25.81	345	11600	1300	800
22.81	265	14500	1000	1000

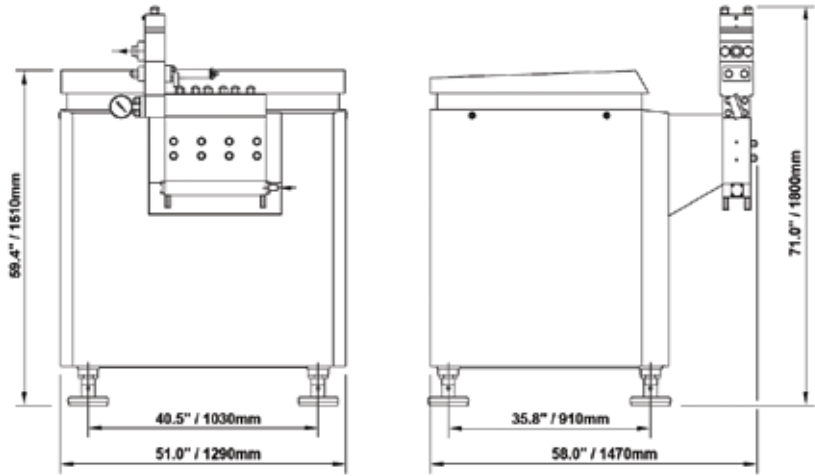

Gaulin/Mono-Block Design

Type	US max. cap./max. press.		Metric max.cap./max. press.	
	GPH	PSI	LPH	BAR
Poppet type valves				
1.5	2960	1500	11200	100
2.5	1750	2500	6640	170
3.0	1505	3000	5700	210
5.8	740	5800	2800	400
Ball type valves				
2.5	1375	2500	5200	170
3.0	1190	3000	4500	210
4.3	820	4300	3100	300
5.8	580	5800	2200	400
8.7	420	8700	1600	600

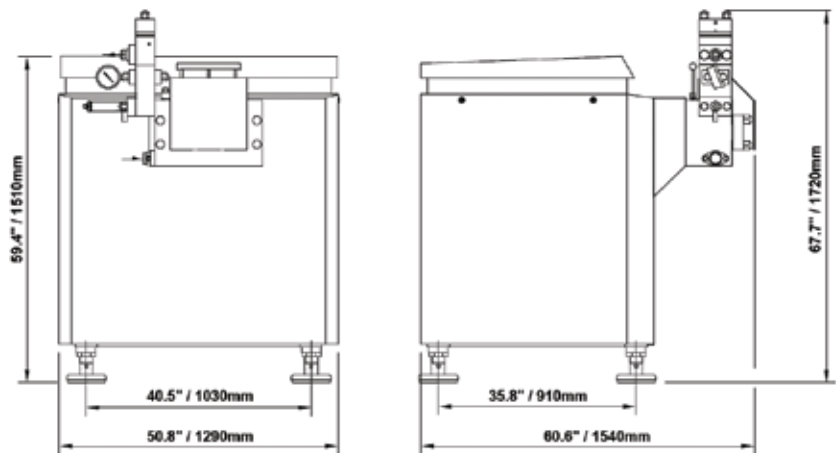

Dimensions (Single Stage)

Dimensions packed in a crate LxWxH (in.)	Dimensions packed in a crate LxWxH (cm)	Cubic measure m ³	Gross weight in a crate, incl. motor
70 x 62 x 82.8	176 x 155 x 207	5.7	4,850 lb./2,200 kg

APV, An SPX Brand
Phone: (888) 278-4321
Email: answers.us@apv.com

For more information about our worldwide locations, approvals, certifications, and local representatives, please visit www.apv.com.

SPX Corporation reserves the right to incorporate our latest design and material changes without notice or obligation. Design features, materials of construction and dimensional data, as described in this bulletin, are provided for your information only and should not be relied upon unless confirmed in writing.

Issued: 08/2008 3023-02-08-2008 Copyright © 2002, 2008 SPX Corporation

SPX
WHERE IDEAS MEET INDUSTRY