



Homogenizer

Rannie 15 /Gaulin 15

Introduction

The Rannie 15 / Gaulin 15 homogenizer, a positive displacement triplex, reciprocating plunger pump, is fitted with an application-specific homogenizing valve assembly: single-stage with manual actuation. As a high-pressure pump, this unit can be fitted with a relief valve.



Rannie three-piece valve housing

The Rannie 15 / Gaulin 15 homogenizer incorporates a durable slow-speed power end that reduces vibration and noise. Easy access to the lubrication oil and other auxiliary systems simplifies maintenance saving time and money. Liquid end options include a three-piece valve housing (Rannie) and a mono-block design (Gaulin) (ball and poppet style). As a standard the homogenizer is equipped with a Stellite XFD homogenizing valve.



Gaulin mono-block design

Design features of both the Rannie and Gaulin simplify routine maintenance. Materials for plungers, packings, pump valves, valve seats and seals are custom-selected for your application. APV engineers will work with you to optimize the configuration for your specific application.

Standard Options

- Two-stage manual
- Single-stage hydraulic valve actuation (HVA)
- Two-stage hydraulic valve actuation (HVA)
- Single-stage automatic hydraulic system (AHS)
- Two-stage automatic hydraulic system (AHS)
- Pulsation dampener(s) on inlet and outlet
- Aseptic cylinder design
- Electronic pressure transmitter excl. display
- High-pressure outlet
- Inlet pressure gauge
- Plunger lubrication control package
- Tungsten carbide homogenizing valve
- Square plunger seals and ceramic plungers (Rannie valve housing only)
- External cooling fan/main motor
- Motor starter
- Control cabinet, stainless steel
- Thermostat/oil temperature

Special Options

- Acid-proof cylinder (Gaulin valve housing only)
- Ceramic plungers with U- or V-rings
- Explosion-proof design
- Electropolished wettables
- High-temperature design
- Flow switch - power end cooling

Rannie/Three-Piece Valve Housing Poppet and Ball Type Valves

Type	US max. cap./max. press.		Metric max.cap./max. press.	
	GPH	PSI	LPH	BAR
42.56	870	2175	3300	150
35.56	600	2900	2300	200
32.56	500	3600	1900	250
30.56	435	4300	1650	300
25.56	295	5800	1120	400
20.56	175	8700	670	600
18.56	105	11600	400	800
16.56	80	14500	300	1000
14.56	40	17400	160	1200
12.56	25	21750	100	1500

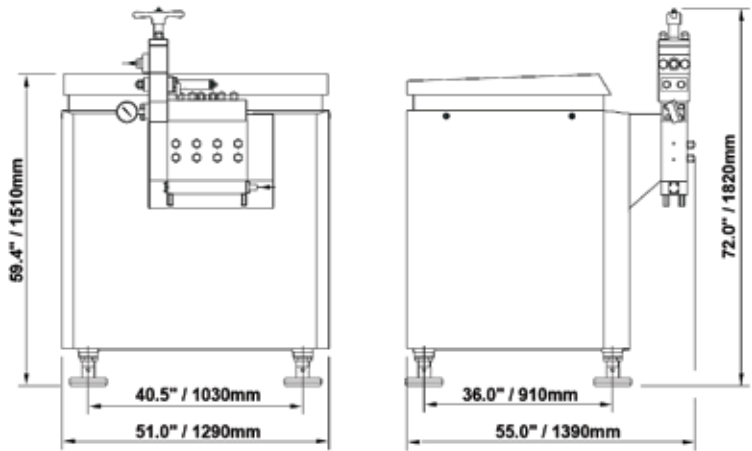

Gaulin/Mono-Block Design

Type	US max. cap./max. press.		Metric max.cap./max. press.	
	GPH	PSI	LPH	BAR
Poppet type valves				
2.5	790	2500	3000	170
3.0	610	3000	2300	210
3.6	500	3600	1900	250
4.3	450	4300	1700	300
5.8	290	5800	1100	400
Ball type valves				
2.5	550	2500	2100	170
3.0	420	3000	1600	210
3.6	340	3600	1300	250
4.3	300	4300	1150	300
5.8	210	5800	800	400
8.7	120	8700	450	600

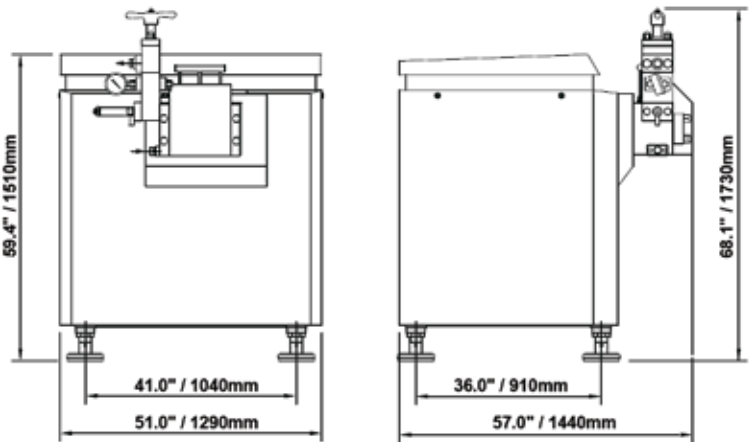

Dimensions (Single Stage)

Dimensions packed in a crate LxWxH (in.)	Dimensions packed in a crate LxWxH (cm)	Cubic measure m ³	Gross weight in a crate, incl. motor
67 x 61 x 82	170 x 155 x 207	5.4	3,968 lb./1,800 kg

APV, An SPX Brand
 Phone: (888) 278-4321
 Email: answers.us@apv.com

For more information about our worldwide locations, approvals, certifications, and local representatives, please visit www.apv.com.

SPX Corporation reserves the right to incorporate our latest design and material changes without notice or obligation. Design features, materials of construction and dimensional data, as described in this bulletin, are provided for your information only and should not be relied upon unless confirmed in writing.

Issued: 08/2008 3021-02-08-2008 Copyright © 2002, 2008 SPX Corporation

SPX
 WHERE IDEAS MEET INDUSTRY