

Evaporator Handbook



CONTENTS

Introduction.....	3
Evaporators.....	4
Evaporator Type Selection.....	20
Configurations For Energy Conservation....	24
Residence Time In Film Evaporation.....	28
Designing For Energy Efficiency.....	32
Physical Properties.....	34
Mechanical Vapor Recompression Evaporators.....	36
Evaporators For Industrial And Chemical Applications.....	42
Waste Water Evaporators.....	47
Evaporator Control.....	50
Preassembled Evaporators.....	52
The Production Of High Quality Juice Concentrates.....	53
Engineering Conversion.....	58
Properties Of Saturated Steam Temperature Tables.....	59

Introduction

As one of the most energy intensive processes used in the dairy, food and chemical industries, it is essential that evaporation be approached from the viewpoint of economical energy utilization as well as process effectiveness. This can be done only if the equipment manufacturer is able to offer a full selection of evaporation technology and systems developed to accommodate various product characteristics, the percent of concentration required, and regional energy costs.

This handbook describes the many types of evaporators and operating options available through the experience and manufacturing capabilities of APV.

Evaporators

Types and Design

In the evaporation process, concentration of a product is accomplished by boiling out a solvent, generally water. The recovered end product should have an optimum solids content consistent with desired product quality and operating economics. It is a unit operation that is used extensively in processing foods, chemicals, pharmaceuticals, fruit juices, dairy products, paper and pulp, and both malt and grain beverages. Also it is a unit operation which, with the possible exception of distillation, is the most energy intensive.

While the design criteria for evaporators are the same regardless of the industry involved, two questions always exist: is this equipment best suited for the duty, and is the equipment arranged for the most efficient and economical use? As a result, many types of evaporators and many variations in processing techniques have been developed to take into account different product characteristics and operating parameters.

Types of Evaporators

The more common types of evaporators include:

- Batch pan
- Forced circulation
- Natural circulation
- Wiped film
- Rising film tubular
- Plate equivalents of tubular evaporators
- Falling film tubular
- Rising/falling film tubular

Batch Pan

Next to natural solar evaporation, the batch pan (Figure 1) is one of the oldest methods of concentration. It is somewhat outdated in today's technology, but is still used in a few limited applications, such as the concentration of jams and jellies where whole fruit is present and in processing some pharmaceutical products. Up until the early 1960's, batch pan also enjoyed wide use in the concentration of corn syrups.

With a batch pan evaporator, product residence time normally is many hours. Therefore, it is essential to boil at low temperatures and high vacuum when a heat sensitive or thermodegradable product is involved. The batch pan is either jacketed or has internal coils or heaters. Heat transfer areas normally are quite small due to vessel shapes, and heat transfer coefficients (HTC's) tend to be low under natural convection conditions. Low surface areas together with low HTC's generally limit the evaporation capacity of such a system. Heat transfer is improved by agitation within the vessel. In many cases, large temperature differences cannot be used for fear of rapid fouling of the heat transfer surface. Relatively low evaporation capacities, therefore, limit its use.

Figure 1

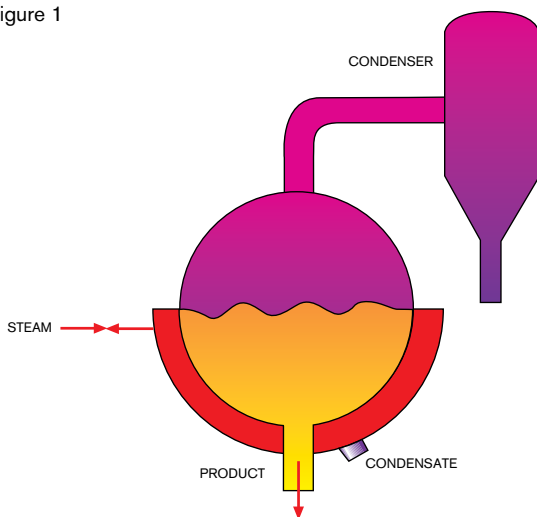

Tubular Evaporators

Natural Circulation

Evaporation by natural circulation is achieved through the use of a short tube bundle within the batch pan or by having an external shell and tube heater outside of the main vessel (Figure 2). The external heater has the advantage that its size is not dependent upon the size or shape of the vessel itself. As a result, larger evaporation capacities may be obtained. The most common application for this type of unit is as a reboiler at the base of a distillation column.

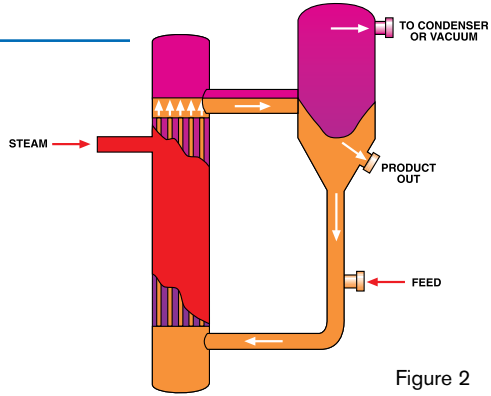

Figure 2

Rising Film Tubular

Considered to be the first 'modern' evaporator used in the industry, the rising film unit dates back to the early 1900's. The rising film principle was developed commercially by using a vertical tube with steam condensing on its outside surface (Figure 3). Liquid on the inside of the tube is brought to a boil, with the vapor generated forming a core in the center of the tube. As the fluid moves up the tube, more vapor is formed resulting in a higher central core velocity that forces the remaining liquid to the tube wall. Higher vapor velocities, in turn, result in thinner and more rapidly moving liquid film. This provides higher HTC's and shorter product residence time.

The development of the rising film principle was a giant step forward in the evaporation field, particularly in product quality. In addition, higher HTC's resulted in reduced heat transfer area requirements and consequently, in a lower initial capital investment.

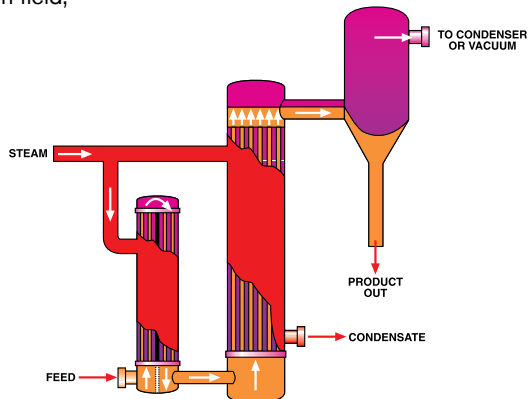

Figure 3

Falling Film Tubular

Following development of the rising film principle, it took almost half a century for a falling film evaporation technique to be perfected (Figure 4). The main problem was how to design an adequate system for the even distribution of liquid to each of the tubes. For the rising film evaporator, distribution was easy since the bottom bonnet of the calandria was always pumped full of liquid, thus allowing equal flow to each tube. While each manufacturer has its own technique, falling film distribution generally is based around use of a perforated plate positioned above the top tube plate of the calandria. Spreading of liquid to each tube is sometimes further enhanced by generating flash vapor at this point. The falling film evaporator does have the advantage that the film is 'going with gravity' instead of against it. This results in a thinner, faster moving film and gives rise to an even shorter product contact time and a further improvement in the value of HTC.

To establish a well-developed film, the rising film unit requires a driving film force, typically a temperature difference of at least 25°F (14°C) across the heating surface. In contrast, the falling film evaporator does not have a driving force limitation—permitting a greater number of evaporator effects to be used within the same overall operating limits. For example, if steam is available at 220°F (104°C), then the last effect boiling temperature is 120°F (49°C); the total available ΔT is equal to 100°F (55°C). In this scenario a rising film evaporator would be limited to four effects, each with a ΔT of 25°F (14°C). However, using the falling film technique, it is feasible to have as many as 10 or more effects.

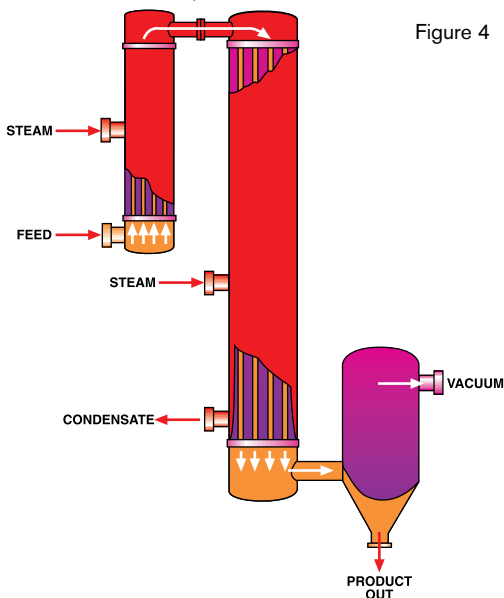

Figure 4

Rising/Falling Film Tubular

The rising/falling film evaporator (Figure 5) has the advantages of the ease of liquid distribution of the rising film unit coupled with lower head room requirements. The tube bundle is approximately half the height of either a rising or falling film evaporator, and the vapor/liquid separator is positioned at the bottom of the calandria.

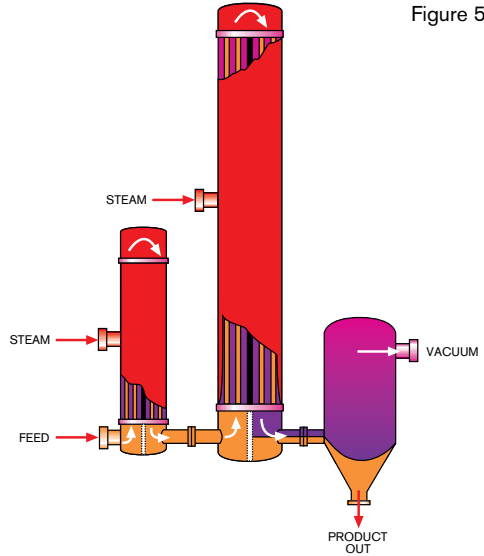

Figure 5

Forced Circulation

The forced circulation evaporator (Figure 6) was developed for processing liquors which are susceptible to scaling or crystallizing. Liquid is circulated at a high rate through the heat exchanger, boiling being prevented within the unit by virtue of a hydrostatic head maintained above the top tube plate. As the liquid enters the separator where the absolute pressure is slightly less than in the tube bundle, the liquid flashes to form a vapor.

The main applications for a forced circulation evaporator are in the concentration of inversely soluble materials, crystallizing duties, and in the concentration of thermally degradable materials which result in the deposition of solids. In all cases, the temperature rise across the tube bundle is kept as low as possible, often as low as 3-5°F (2-3°C). This results in a recirculation ratio as high as 220 to 330 lbs (100 to 150 Kg) of liquor per pound (kilogram) of water evaporated. These high recirculation rates result in high liquor velocities through the tube which help to minimize the build up of deposits or crystals along the heating surface. Forced circulation evaporators normally are more expensive than film evaporators because of the need for large bore circulating pipework and large recirculating pumps. Operating costs of such a unit also are considerably higher.

Figure 6

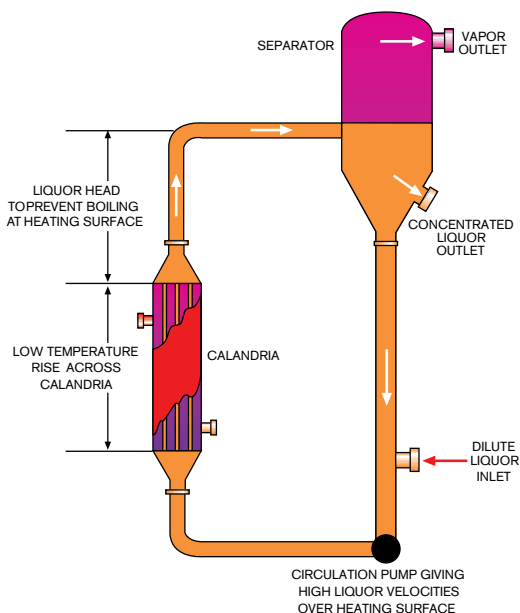

Wiped Film

The wiped or agitated thin film evaporator has limited applications due to the high cost and is confined mainly to the concentration of very viscous materials and the stripping of solvents down to very low levels. Feed is introduced at the top of the evaporator and is spread by wiper blades on to the vertical cylindrical surface inside the unit. Evaporation of the solvent takes place as the thin film moves down the evaporator wall. The heating medium normally is high pressure steam or oil.

A high temperature heating medium generally is necessary to obtain a reasonable evaporation rate since the heat transfer surface available is relatively small as a direct result of its cylindrical configuration.

The wiped film evaporator is satisfactory for its limited applications. However, in addition to its small surface area, it also has the disadvantage of requiring moving parts such as the wiper blades which, together with the bearings of the rotating shaft, need periodic maintenance. Capital costs in terms of dollars per pound of solvent evaporated also are very high.

Plate Type Evaporators

To effectively concentrate an increasing variety of products which differ by industry in such characteristics as physical properties, stability, or precipitation of solid matter, equipment manufacturers have engineered a full range of evaporation systems. Included among these are a number of plate type evaporators (Figure 7).

Plate evaporators initially were developed and introduced by APV in 1957 to provide an alternative to the tubular systems that had been in use for half a century. The differences and advantages were many. The plate evaporator, for example, offers full accessibility to the heat transfer surfaces. It also provides flexible capacity merely by adding more plate units, shorter product residence time resulting in a superior quality concentrate, a more compact design with low headroom requirements, and low installation cost.



Figure 7

These APV plate evaporation systems are made in four arrangements — Rising/Falling Film, Falling Film, Paravap, and Forced Circulation — and may be sized for use in new product development or for production at pilot plant or full scale operating levels.

APV plate type evaporators have been sold commercially for over 50 years. Approximately 2000 systems have been manufactured by APV for the concentration of hundreds of different products.

Applications

Although plate evaporators can be used on a broad range of products, the main application has been with products that are heat sensitive and therefore benefit from the high HTC's and low residence time. Products that are being processed in this evaporator include:

- Apple juice
- Amino acids
- Beef broths
- Beet juice
- Betacyclodextrin
- Caragenan
- Cheese whey
- Chicken broth
- Citrus juice
- Coffee
- Fruit purees
- Gelatin
- Grape juice
- Lime juice
- Liquid egg
- Low alcohol beer
- Mango juice
- Orange juice
- Pear juice
- Pectin
- Pharmaceutical products
- Pineapple juice
- Skim milk
- Sugars
- Vegetable juices
- Whey protein
- Whole milk

Rising/Falling Film Plate

This is the original plate type evaporator. The principle of operation for the rising/falling film plate evaporator (RFFPE) involves the use of a number of plate packs or units, each consisting of two steam plates and two product plates. These are hung in a frame which resembles that of a plate heat exchanger (Figure 8). The first product passage is a rising pass and the second, a falling pass. The steam plates, meanwhile, are arranged alternately between each product passage.

Figure 8

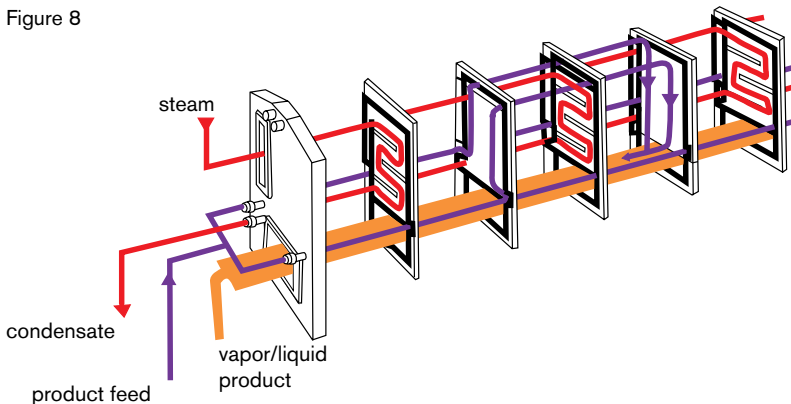

The product to be evaporated is fed through two parallel feed ports and is equally distributed to each of the rising film annuli. Normally, the feed liquor is introduced at a temperature slightly higher than the evaporation temperature in the plate annuli, and the ensuing flash distributes the feed liquor across the width of the plate. Rising film boiling occurs as heat is transferred from the adjacent steam passage with the vapors that are produced helping to generate a thin, rapidly moving turbulent liquid film.

During operation, the vapor and partially concentrated liquid mixture rises to the top of the first product pass and transfers through a 'slot' above one of the adjacent steam passages. The mixture enters the falling film annulus where gravity further assists the film movement and completes the evaporation process. The rapid movement of the thin film is the key to producing low residence time within the evaporator as well as superior HTC's. At the base of the falling film annulus, a rectangular duct connects all of the plate units and transfers the evaporated liquor and generated vapor into a separating device. A flow schematic for a two effect system is shown in (Figure 9).

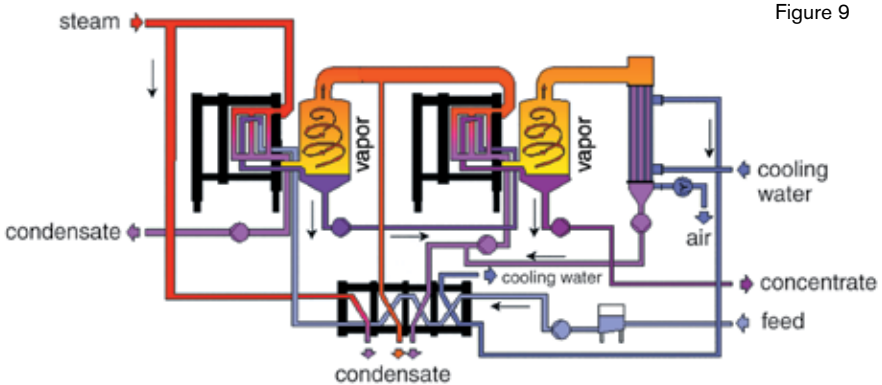

Figure 9

The plate evaporator is designed to operate at pressures extending from 10 psig (1.7 barg) to full vacuum when using any number of effects. However, the maximum pressure differential normally experienced between adjacent annuli during single effect operation is 15 psi (1 bar). This, and the fact that the pressure differential always is from the steam side to the product side, considerably reduce design requirements for supporting the plates. The operating pressures are equivalent to a water vapor saturation temperature range of 245°F (118°C) downwards, and thus are compatible with the use of nitrile or butyl rubber gaskets for sealing the plate pack.

Most rising/falling film plate evaporators are used for duties in the food, juice and dairy industries where low residence time and a temperature lower than 195°F (90°C) are essential for the production of quality concentrate. Also, increasing number of plate evaporators are being operated successfully in both pharmaceutical and chemical plants on such products as antibiotics and inorganic acids. These evaporators are available as multi-effect and/or multi-stage systems to allow relatively high concentration ratios to be carried out in a single pass, non-recirculating flow.

The rising/falling film plate evaporator should be given consideration for various applications that:

- Require operating temperatures between 80-212°F (26 to 100°C)
- Have a capacity range of 1000-35,000 lbs/hr (450 to 16,000 kg/hr water removal)
- Have a need for future capacity increase since evaporator capabilities can be extended by adding plate units or by the addition of extra effects
- Require the evaporator to be installed in an area that has limited headroom as low as 13 ft (4m)
- Where product quality demands a low time/temperature relationship
- Where suspended solid level is low and feed can be passed through 50 mesh screen

A 'Junior' version of the evaporator (Figure 10) is available for pilot plant and test work and for low capacity production. If necessary, this can be in multi-effect/multi-stage arrangements.



Figure 10

Falling Film Plate

Incorporating all the advantages of the original rising/falling film plate evaporator system with the added benefits of shorter residence time and larger evaporation capabilities, the falling film plate evaporator has gained wide acceptance for the concentration of heat sensitive products. With its larger vapor ports, evaporation capacities are typically up to 60,000 lbs/hr (27,000 kg/hr).

Figure 11

The falling film plate evaporator consists of gasketed plate units (each with a product and a steam plate) compressed within a frame that is ducted to a separator. The number of plate units used is determined by the duty to be handled.

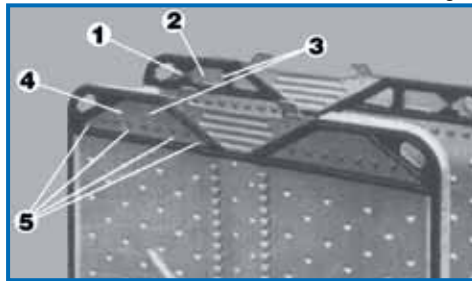

One of the important innovations in this type of evaporator is the patented feed distribution system (Figure 11). Feed liquor first is introduced through an orifice (1) into a chamber (2) above the product plate where mild flashing occurs. This vapor/liquid mixture then passes through a single product transfer hole (3) into a flash chamber (4) which extends across the top of the adjacent steam plate. More flash vapor results as pressure is further reduced and the mixture passes in both directions into the falling film plate annulus through a row of small distribution holes (5). These assure an even film flow down the product plate surface where evaporation occurs. A unique feature is the ability to operate the system either in parallel or in series, giving a two-stage capability to each frame. This is particularly advantageous if product recirculation is not desirable.

Figure 12

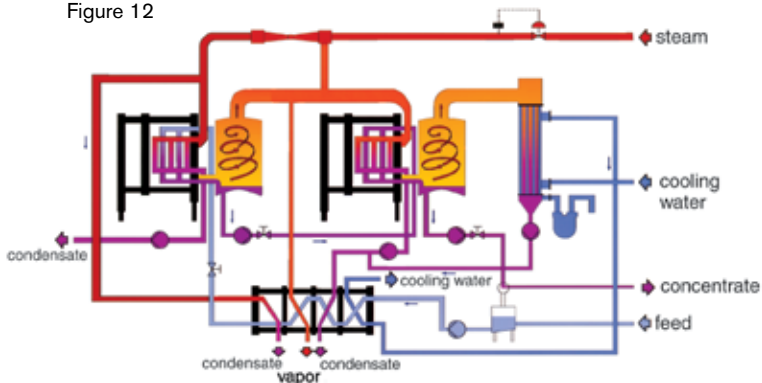

In the two-stage method of operation, feed enters the left side of the evaporator and passes down the left half of the product plate where it is heated by steam coming from the steam sections. After the partially concentrated product is discharged to the separator, it is pumped to the right side of the product plate where concentration is completed. The final concentrate is extracted while vapor is discharged to a subsequent evaporator effect or to a condenser. The falling film plate is available in an extended form which provides up to 4000 ft² (370m²) surface area in one frame. A flow schematic for a two effect system (Figure 12) is shown above. An APV falling film evaporator in triple effect mode (Figure 13) is shown below.



Figure 13. Plant representation. Triple-effect Falling Film Evaporator system followed by a double-effect forced circulation tubular finisher. A distillation essence recovery system was provided to recover the key essence components from the juice and in particular the methyl anthranilate.

The APV Paravap Evaporation System

The Process

The APV Paravap evaporation system is designed for the evaporation of highly viscous liquids. The system is often used as a finishing evaporator to concentrate materials to high solids following a low solids multi-effect or MVR film evaporator.

The main components of the system are a plate heat exchanger, vapor liquid separator, condenser and a series of pumps (Figure 14). It is designed to operate as a climbing film evaporator with the evaporation taking place in the plate passages. Compared with forced circulation evaporators, the pumping costs are significantly reduced.

Under normal operating conditions the feed is introduced at the bottom of the plates. As the feed contacts the plate surface, which is heated by either steam or hot water, the feed starts to evaporate. The narrow gap and corrugations in the plate passages cause high turbulence and a resulting partial atomization of the fluid. This reduces the apparent liquid viscosity and generates considerably higher HTC's than would occur in a shell and tube heat exchanger under similar conditions. It is particularly effective with non-Newtonian viscous liquids.

Figure 14

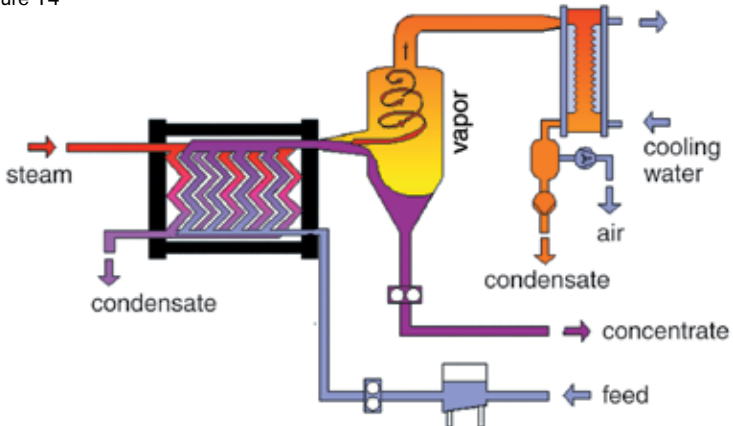

A clear advantage when processing temperature sensitive products is gained with a Paravap because most duties do not require liquid recirculation. For most duties the conventional gasketed plate heat exchanger is specified. However, for duties where the process fluid could attack the gasket, APV can offer the welded plate pair exchanger which eliminates elastomer gaskets on the process side.

The Paravap is usually operated in single effect mode although some systems are operating with double effect.

Since most systems are not physically large, the equipment can often be fully preassembled on a skid prior to shipment. Preassembly reduces installation time and, in most cases, significantly lowers the overall project cost.

The Paravap evaporation system is particularly effective in processing the more viscous products. Often the Paravap can be used in place of a wiped film or thin film evaporator with a substantial reduction in cost. For duties where severe fouling can occur on boiling heat transfer surfaces, the process should be performed in an APV Forced Circulation Evaporator.

Some typical duties that are performed in a Paravap include:

- Sodium hydroxide
- Concentration of sugar solutions to extremely high solids content
- In one case a solids concentration of 98% was achieved
- Removal of water from soaps
- Finishing concentrator on certain fruit purees such as banana and apple
- Concentration of high solids corn syrups
- Removal of solvents from vegetable oils
- Concentration of fabric softeners
- Lignin solutions
- High concentration gelatin
- High concentration chicken broth

The APV Forced Circulation Evaporator System

The Process

The APV Forced Circulation Evaporator System is designed for the evaporation of liquids containing high concentrations of solids. In particular, the system is used as a finishing evaporator to concentrate materials to high solids following a low solids multi-effect or MVR film evaporator.

The main components of the system are a plate heat exchanger, vapor liquid separator, condenser and a series of pumps (Figure 15). It is designed to operate as a forced circulation evaporator with the evaporation being suppressed in the heating section by back pressure. This back pressure can be generated by a liquid head above the exchanger or by using an orifice piece or valve in the discharge from the evaporator. The evaporation then occurs as the liquid flashes in the entrance area to the separator.

The suppression of boiling, together with the high circulation rate in the plate heat exchanger, result in less fouling than would occur in other types of evaporators. This increases the length of production runs between cleanings.

In addition, the narrow gap and corrugations in the plate passages result in far higher heat transfer rates than would be obtained in shell and tube systems.

Figure 15

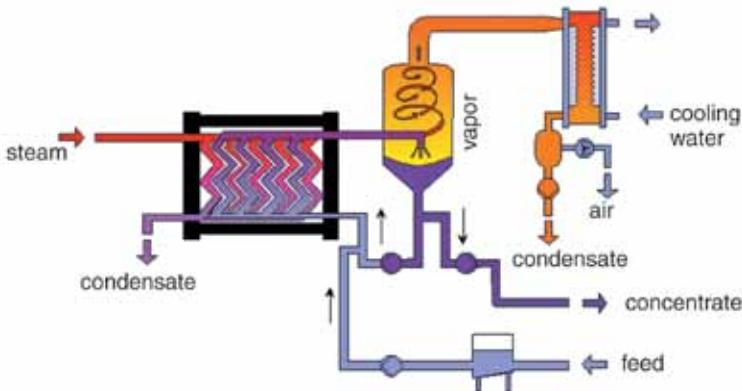

For most duties the conventional gasketed plate heat exchanger is specified. However for duties where the process fluid could attack the gasket, APV can offer the welded plate pair exchanger which eliminates elastomer gaskets on the process side.

The APV Forced Circulation Evaporator System can be used either as a single or multiple effect evaporator.

Since many systems are not physically large, the equipment can often be fully preassembled on a skid prior to shipment. Preassembly reduces installation time and, in most cases, significantly lowers the overall project cost.

Because of the large range of viscosities that can be handled in a forced circulation evaporator, this form of evaporator can economically handle a wider range of duties than any other evaporator. In particular, due to the high turbulence and corresponding high shear rates, the APV Forced Circulation Evaporator is excellent at handling non-Newtonian fluids with high suspended solids content.

Some typical duties that are performed in an APV Forced Circulation Evaporator include:

- Concentration of wash water from water based paint plants to recover the paint and clean the water
- Removal of water from dyestuffs prior to drying
- Finishing concentrator on waste products from breweries and distilleries
- Concentration of brewer's yeast
- Concentration of kaolin slurries prior to drying
- Recovery of solvents in wastes from cleaning operations
- Evaporation of solvents from pharmaceutical products
- Crystallization of inorganic salts
- Cheese whey

Evaporator Type Selection

The choice of an evaporator best suited to the duty on hand requires a number of steps. Typical rules of thumb for the initial selection are detailed below. A selection guide (Figure 16), based on viscosity and the fouling tendency of the product is shown below on next page.

Mode of Evaporation

The user needs to select one or more of the various types of evaporator modes that were described in the previous section. To perform this selection, there are a number of 'rules of thumb' which can be applied.

- Falling film evaporation:
 - either plate or tubular, provides the highest heat transfer coefficients
 - is usually the mode chosen if the product permits
 - will usually be the most economic
 - is not suitable for the evaporation of products with viscosities over 300cp
 - is not suitable for products that foul heavily on heat transfer surfaces during boiling
- Forced circulation evaporators:
 - can be operated up to viscosities of over 5,000cp
 - will significantly reduce fouling
 - are expensive; both capital and operating costs are high
- Paravap evaporators:
 - are suitable for viscosities up to 10,000cp for low fouling duties
 - are suitable for very high viscosities, i.e., over 20,000cp, usually the only suitable evaporation modes are the wiped film and thin film systems

Film Evaporators—Plate or Tubular

- Plate evaporators:
 - provide a gentle type of evaporation with low residence times and are often the choice for duties where thermal degradation of product can occur
 - often provide enhanced quality of food products
 - require low headroom and less expensive building and installation costs
 - are easily accessed for cleaning
 - provide added flexibility, since surface area can easily be added or removed
- Tubular evaporators:
 - are usually the choice for very large evaporators
 - are usually the choice for evaporators operating above 25 psia (1.7 bar)
 - are better at handling large suspended solids
 - require less floor space than plate evaporators
 - have fewer gasket limitations

Forced Circulation Evaporators—Plate or Tubular

- Plate systems will provide much higher HTC's for all duties. With viscous products, the plate exhibits vastly improved performance compared with a tubular.
- Tubular systems must be selected when there are particulates over 2mm diameter.

The APV Paravap

- For low fouling viscous products such as high brix sugar, the Paravap system is always the preferred solution.

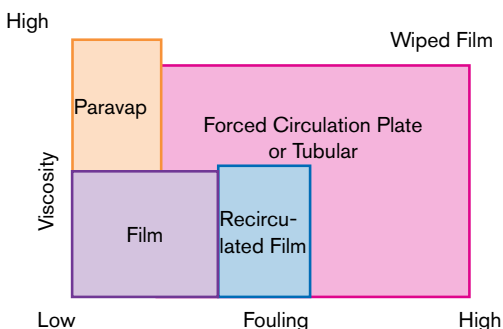

Figure 16

This diagram shows a selection guide based on the viscosity and fouling tendency of the product.

Materials of Construction

The two parameters which control the selection of the material of construction are corrosion and ease of cleaning.

All evaporators for hygienic duties must be capable of being frequently cleaned in place. In most cases, this means rinsing the equipment with water, followed by washing with caustic and then acid cleaning agents, and finally, a further rinsing with water. It is important, particularly with dairy and meat products, that the evaporator is completely cleaned of all deposits. The cleaning processes eliminate the use of carbon steel as the material of construction. Most hygienic evaporators are manufactured in either 304 or 316 stainless steel.

Corrosion is often a major problem with chemical duties and some hygienic applications. A particular problem with evaporators is the range of concentration of solids in the process fluid, since the corrosive component will be concentrated as it passes through the evaporator. In some evaporators, the concentration range can be as high as 50 to 1. For example, waste water with a chloride content of 40ppm in the feed would have 2000ppm in the product. While stainless steel would be acceptable for the initial stages of evaporation, a more corrosion resistant material would be required for the last one or two stages.

Corrosion is also a major consideration in the selection of gasket materials. This is particularly important with plate evaporators with elastomeric gaskets sealing each plate. Many solvents such as chlorinated and aromatic compounds will severely attack the gaskets. A less obvious form of attack is by nitric acid. This is important since nitric acid can be present in some cleaning materials. While concentrations of about 1% up to 140°F (60°C) can be accepted, it is best to eliminate nitric acid from cleaning materials. Phosphoric and sulfamic acids are less aggressive to gaskets.

It is not the purpose of this handbook to provide guidelines for the selection of materials of construction. The reader is referred to the APV Corrosion Handbook, as well as the many publications issued by the material manufacturers.

Typical materials of construction for a number of evaporator applications are shown below:

Product	Material of Construction
Most dairy and food products	304/316 stainless steel
Most fruit juices	316 stainless steel
Sugar products	Carbon steel /304/316
Foods containing high salt (NaCl)	Titanium/Monel High alloy stainless steels Duplex stainless steels
Caustic soda < 40%	Stress relieved carbon steel
Caustic soda high concentration	Nickel
Hydrochloric acid	Graphite/Rubber lined carbon steel

In some cases, the type of evaporator is controlled by the materials of construction. For example a sulfuric acid evaporator, where the acid concentration can reach 50%, would utilize graphite tubular heat exchangers and non-metallic separators and piping.

Evaporator Configurations for Energy Conservation

Conservation of energy is one major parameter in the design of an evaporator system. The larger the evaporation duty, the more important it is to conserve energy.

The following techniques are available:

Multi-Effect Evaporation

Multi-effect evaporation uses the steam produced from evaporation in one effect to provide the heat to evaporate product in a second effect which is maintained at a lower pressure (Figure 17). In a two effect evaporator, it is possible to evaporate approximately 2 kgs of steam from the product for each kg of steam supply. As the number of effects is increased, the steam economy increases. On some large duties it is economically feasible to utilize as many as seven effects.

Increasing the number of effects, for any particular duty, does increase the capital cost significantly and therefore each system must be carefully evaluated. In general, when the evaporation rate is above 3,000 lbs/h (1,350 kg/h), multi-effect evaporation should be considered.

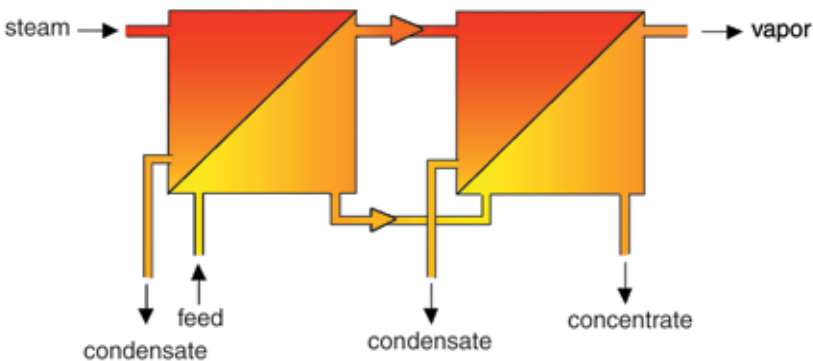

Figure 17

Thermo Vapor Recompression (TVR)

When steam is available at pressures in excess of 45 psig (3 barg) and preferably over 100 psig (7 barg), it will often be possible to use thermo vapor recompression. In this operation, a portion of the steam evaporated from the product is recompressed by a steam jet venturi and returned to the steam chest of the evaporator. A system of this type can provide a 2 to 1 economy or higher depending on the product the steam pressure and the number of effects over which TVR is applied.

TVR is a relatively inexpensive technique for improving the economy of evaporation.

TVR can also be used in conjunction with multi-effect to provide even larger economies (Figure 18). Shown in (Figure 19) are the economies that can be achieved.

Thermocompressors are somewhat inflexible and do not operate well outside the design conditions. Therefore if the product is known to foul severely, so that the heat transfer coefficient is significantly reduced, it is best not to use TVR. The number of degrees of compression is too small for materials that have high boiling point elevation.

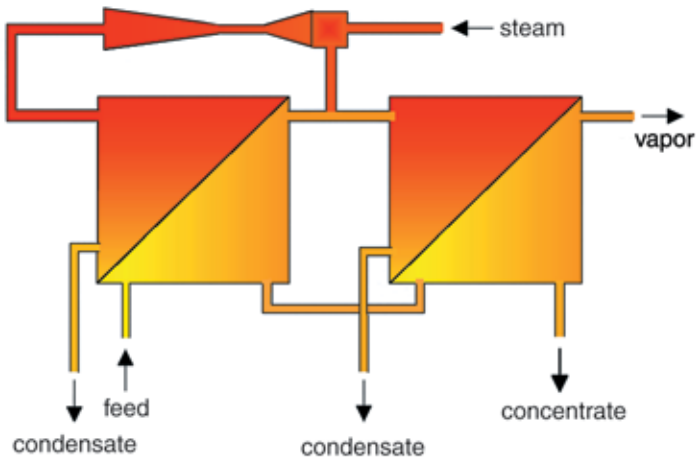

Figure 18

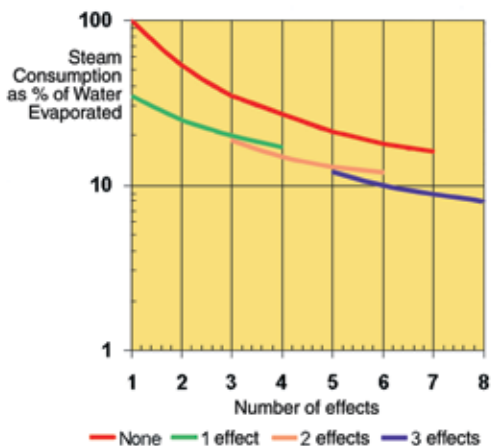

Figure 19

Mechanical Vapor Recompression (MVR)

Thermodynamically, the most efficient technique to evaporate water is to use mechanical vapor thermorecompression. This process takes the vapor that has been evaporated from the product, compresses the vapor mechanically and then uses the higher pressure vapor in the steam chest (Figure 20).

The vapor compression is carried out by a radial type fan or a compressor. The fan provides a relatively low compression ratio of 1:30 which results in high heat transfer surface area but an extremely energy efficient system. Although higher compression ratios can be achieved with a centrifugal compressor, the fan has become the standard for this type of equipment due to its high reliability, low maintenance cost and generally lower RPM operation.

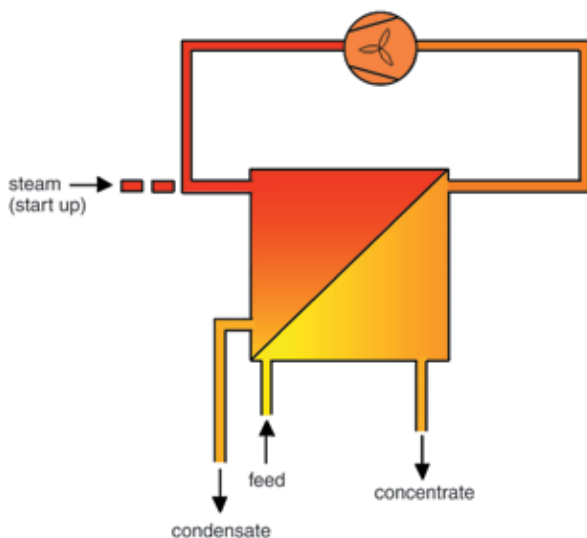

Figure 20

This technique requires only enough energy to compress the vapor because the latent heat energy is always re-used. Therefore, an MVR evaporator is equivalent to an evaporator of over 100 effects. In practice, due to inefficiencies in the compression process, the equivalent number of effects is in the range 30 to 55 depending on the compression ratio.

The energy supplied to the compressor can be derived from an electrical motor, steam turbine, gas turbine and internal combustion engine. In any of the cases the operating economics are extremely good.

Since the costs of the compressors are high, the capital cost of the equipment will be significantly higher than with multi-effect. However in most cases, for medium size to large evaporators, the pay back time for the addition capital will only be 1 to 2 years.

Like the one TVR, the two MVR system is not appropriate for high fouling duties or where boiling point elevation is high.

Combination of Film and Forced Circulation Evaporators

The most economic evaporators utilize falling film tubulars or plates, with either TVR or MVR. However with many duties, the required concentration of the final product requires a viscosity that is too high for a film evaporator. The solution is to use film evaporation for the pre-concentration and then a forced circulation finisher evaporator to achieve the ultimate concentration; e.g., a stillage or spent distillery wash evaporator. The material would typically be concentrated from 4% to 40% in a falling film evaporator and then from 40% to 50% in a forced circulation evaporator. Usually the finisher would be a completely separate evaporator since the finisher duty is usually relatively low. In the duty specified above, almost 98% of the evaporation would take place in the high efficiency film evaporator.

For cases where the finisher load is relatively high, it is possible to incorporate the forced circulation finisher as one of the effects in a multi-effect evaporator. However this is an expensive proposition due to the low coefficients at the high concentration.

Residence Time in Film Evaporation

Since many pharmaceutical, food and dairy products are extremely heat sensitive, optimum quality is obtained when processing times and temperatures are kept as low as possible during concentration of the products. The most critical portion in the process occurs during the brief time that the product is in contact with a heat transfer surface which is hotter than the product itself. To protect against possible thermal degradation, the time/temperature relationship therefore must be considered in selecting the type and operating principle of the evaporator to be used.

For this heat sensitive type of application, film evaporators have been found to be ideal for two reasons. First, the product forms a thin film only on the heat transfer surface rather than occupying the entire volume, greatly reducing residence time within the heat exchanger. Second, a film evaporator can operate with as low as 6°F (3.5°C) steam-to-product temperature difference. With both the product and heating surfaces close to the same temperature, localized hot spots are minimized.

As previously described, there are rising film and falling film evaporators as well as combination rising/falling film designs. Both tubular and plate configurations are available.

Comparison Of Rising Film And Falling Film Evaporators

In a rising film design, liquid feed enters the bottom of the heat exchanger and when evaporation begins, vapor bubbles are formed. As the product continues up either the tubular or plate channels and the evaporation process continues, vapor occupies an increasing amount of the channel. Eventually, the entire center of the is filled with vapor while the liquid forms a film on the heat transfer surface.

The effect of gravity on a rising film evaporator is twofold. It acts to keep the liquid from rising in the channel. Further, the weight of the liquid and vapor in the channel pressurizes the fluid at the bottom and with the increased pressure comes an increase in the boiling point. A rising film evaporator therefore requires a larger minimum ΔT than a falling film unit.

The majority of the liquid residence time occurs in the lower portion of the channel before there is sufficient vapor to form a film. If the liquid is not preheated above the boiling point, there will be no vapor. And since a liquid pool will fill the entire area, the residence time will increase.

As liquid enters the top of a falling film evaporator, a liquid film formed by gravity flows down the heat transfer surface. During evaporation, vapor fills the center of the channel and as the momentum of the vapor accelerates the downward movement, the film becomes thinner. Since the vapor is working with gravity, a falling film evaporator produces thinner films and shorter residence times than a rising film evaporator for any given set of conditions.

Tubular And Plate Film Evaporators

When compared to tubular designs, plate evaporators offer improved residence time since they carry less volume within the heat exchanger. In addition, the height of a plate evaporator is less than that of a tubular system.

Estimating Residence Time

It is difficult to estimate the residence time in film evaporators, especially rising film units. Correlations, however, are available to estimate the volume of the channel occupied by liquid. Formula (1) is recommended for vacuum systems.

For falling film evaporators, the film thickness without vapor shearing can be calculated by Formula (2).

Since the film is thin, this can be converted to liquid volume fraction in a tubular evaporator by Formula (3).

For a falling film plate evaporator, Formula (4) is used. As liquid travels down the plate and evaporation starts, vapors will accelerate the liquid. To account for this action, the rising film correlation is used when the film thickness falls below that of a falling film evaporator. In practice, the film thickness may be less than estimated by either method because gravity and vapor momentum will act on the fluid at the same time.

Once the volume fraction is known, the liquid residence time is calculated by formula (5). In order to account for changing liquid and vapor rates, the volume fraction is calculated at several intervals along the channel length. Evaporation is assumed to be constant along with channel length except for flash due to high feed temperature.

SYMBOLS	
A	cross sectional area
d	tube diameter
g	gravitational constant
L	tube length
m	film thickness
R_L	liquid volume fraction
q_L	liquid rate
t	time
G	liquid wetting rate
r_L	liquid density
r_v	vapor density
μ	liquid viscosity
y	local weight fraction of vapor
References	
a)	HTRI report, BT-2, pg. 7 (May 1978)
b)	Perry's Chemical Engineer's Handbook, 5th edition, 5-57

FORMULAS	
(1)	$R_L = 1 - \frac{1}{1 + \left(\frac{1-y}{y}\right) \left(\frac{2\rho_v}{\rho_L}\right)^5}$
(2)	$m = \left[\frac{3 \Gamma \mu}{g \rho_L (\rho_L - \rho_v)} \right]^{1/3}$
(3)	$R_L = \frac{4m}{d}$
(4)	$R_L = \frac{2m}{Z}$
(5)	$t = \frac{R_L AL}{q_L}$

CONTACT TIME	RISING FILM TUBULAR	RISING FILM PLATE (C)	FALLING FILM TUBULAR	FALLING FILM PLATE
1st effect	88	47 (A)	23	16 (A)
2nd effect	62	20	22	13
3rd effect	118	30	15	9
4th effect	236 (A)	78 (A)	123 (A)	62 (B)
Total Contact Time	504	175	183	100
(A) two stages (B) three stages (C) plate gap .3 in (7.5mms)				

The table above shows a comparison of contact times for typical four-effect evaporators handling 40,000 lb/h (18,000 kg/h) of feed. The tubular designs are based on 2 in. (51 mm) OD tube, 30 feet (9m) long. Incidentally, designs using different tube lengths do not change the values for a rising film tubular system.

The given values represent total contact time on the evaporator surface, which is the most crucial part of the processing time. Total residence time would include contact in the preheater and separator, as well as additional residence within interconnecting piping.

While there is no experimental data available to verify these numbers, experience with falling film plate and tubular evaporators shows that the values are reasonable. It has been noted that Formula (2) predicts film thicknesses that are too high as the product viscosity rises. Therefore, in actuality, 4th effect falling film residence times probably are somewhat shorter than charted.

Summary

Film evaporators offer the dual advantages of low residence time and low temperature difference which help assure a high product quality when concentrating heat sensitive products. In comparing the different types of film evaporators that are available, falling film designs provide the lowest possible ΔT , and the falling film plate evaporator provides the shortest residence time.

Designing for Energy Efficiency

Although the concentration of liquids by evaporation is an energy intensive process, there are many techniques available, as detailed in previous sections, to reduce the energy costs. However, increased energy efficiency can only be achieved by additional capital costs. As a general rule, the larger the system, the more it will pay back to increase the thermal efficiency of the evaporator.

The problem is to select the correct technique for each application. The main factors that will affect the selection of the technique are detailed below.

Evaporation Rate

The higher the capacity of the evaporator, the more the designer can justify complex and expensive evaporation systems in order to provide high energy efficiency.

For evaporator design purposes, the capacity is defined as the evaporation rate per hour. However, in some applications such as seasonal fruit juice processors, the equipment is only operated for part of the year. This means that an expensive evaporator is idle for part of the year. The economic calculation has to include annual operating hours.

For low capacities the designer is less concerned about energy efficiency. If the evaporation rate is below 2,200 lb/h (1000 kg/h), it is difficult to justify multi-effect evaporation. Usually a single-effect evaporator, often with thermo vapor recompression (TVR), is the system of choice at this capacity.

In many cases, mechanical vapor recompression (MVR) is the most efficient evaporator. However, these systems operate at a low temperature difference, which results in high heat transfer area. Also MVR requires either a centrifugal compressor or a high pressure fan which are expensive equipment items. These cannot usually be justified for low capacity evaporators.

Steam/Electricity Costs

For medium to large duties, a selection has to be made between multi-effect and MVR. A critical parameter that will affect this selection are steam costs relative to electricity costs. Providing process conditions are favorable, MVR evaporation will be more economic, particularly in areas where the electricity cost is low, such as localities around major hydro generating plants. However if low cost steam is available, even at pressures as low as atmospheric, then multi-effect evaporation will be usually more economic due to the lower capital cost.

Steam Pressure

The availability of steam at a medium pressure of about 100 psig (7 barg), permits the efficient use of TVR either on a single or multi-effect evaporator. TVR can be applied across one, two or even three effects. This is the simplest and least costly technique for enhancing evaporator efficiency. The effectiveness declines significantly as the available steam pressure is reduced.

Material of Construction

The majority of evaporators are made in 304 or 316 stainless steel. However there are occasions that much more expensive materials of construction are required, such as 904L, 2205, nickel, Hastelloy C, titanium and even graphite.

These expensive materials skew the economic balance, with the capital cost becoming more significant in the equation. Typically MVR would become less economic as the material cost increases, due to the size of the heat exchangers required.

Physical Properties

There are a number of physical properties that can severely influence the selection of an evaporator.

Boiling Point Elevation

A boiling point elevation of over 5°F (3°C) essentially eliminates MVR evaporators from consideration. This can be partially circumvented by using MVR as a pre concentrator. Once the concentration is sufficient to produce significant boiling point elevation, the final evaporation would be performed in a steam driven finisher.

Product Viscosity

High product viscosity of over 300 to 400cp usually eliminates falling film evaporators in favor of forced circulation. Forced circulation requires a higher temperature difference, which eliminates MVR. TVR is used on some duties.

Product Fouling

Both MVR and TVR are not particularly suitable for duties where severe fouling of heat transfer surfaces occurs over a short time period. The performance of these evaporators will fall off more rapidly than with a multi-effect system. Forced circulation evaporators with suppressed boiling usually perform better with high fouling than film evaporators.

Temperature Sensitive Products

Many products, particularly in the food industry, are prone to degradation at elevated temperatures. The effect is usually made worse by extended residence time. This problem limits the temperature range for multi-effect systems. For example on a milk evaporator, the temperature is limited to a maximum of 160°F (71°C). Since a typical minimum boiling temperature is 120°F (49°C), there is a limited temperature difference to perform the evaporation. This type of duty is suitable for MVR since the evaporation occurs at essentially the same temperature. Although a lower operating temperature increases the size of the major equipment, MVR is the most economic solution for large capacity dairy evaporators.

In many cases the selection of the energy conservation technique is obvious. However, for many applications it is necessary to evaluate a number of techniques in detail before a decision can be made.

The following case study illustrates the various options to save energy using different techniques.

The duty is to concentrate skim milk from 8% solids to 48% by evaporation. The feed rate is 100,000 lb/h (45,500 kg/h). The data shown in the table below summarizes the performance and costs for a straight 5 effect evaporator, a 5 effect evaporator with TVR across 3 effects, and a mechanical vapor recompression evaporator.

No pasteurizer is included in this cost comparison.

Annual operating costs are based on 7,000 h/year of operation, with a steam cost of \$12.50/1000 lb (454 kg) and electricity at \$0.085/kwh.

		5 EFFECT	5 EFFECT WITH TVR	MVR
Evaporation	lb/h	83,000	83,000	83,000
	kg/h	37,900	37,900	37,900
Steam Consumed	lb/h	17,000	11,000	0
	kg/h	7,700	5,000	0
Absorbed power	kw	70	60	560
Annual costs				
Steam		\$1,487,500	\$962,500	0
Electricity		\$41,650	\$35,700	\$333,200
Total		\$1,529,150	\$998,200	\$333,200
Capital costs				
Equipment		\$3,100,000	\$3,300,000	\$3,750,000

The examples illustrate that with a higher capital investment, it is possible to significantly reduce the operating costs of the equipment. However the most economic selection is controlled by the steam and electricity prices. For example, if the dairy is located alongside an electric co-generation plant, the steam cost would be reduced considerably lower, and a steam heated evaporator would be the most economic.

A less important, but still significant factor, is the cost of cooling water. An MVR evaporator requires virtually no cooling water. On a steam heated system the cooling water requirement is about 6 US gallons per lb (.05 m3 per kg) of steam applied.

Mechanical Vapor Recompression Evaporators

Mechanical vapor recompression (MVR) evaporation provides an extremely energy efficient technique for the concentration of solids in water. Usually the capital cost of an MVR system is higher than a comparable steam driven evaporator. However, as the capacity of the system increases the relative cost difference decreases. Although MVR evaporators are seldom chosen for small duties, the concept is often used for medium to large capacity evaporators.

MVR Defined

The basic principle of MVR is to remove the steam that is evaporated from the product, compress it in a mechanical device, and use the higher pressure steam, which has a corresponding higher saturation temperature, to provide the heating medium for the evaporation (Figure 21). No steam input is required once the system is operating. The small difference in enthalpy between the vapors on the condensing and boiling sides is the theoretical energy required to perform the evaporation. Essentially, the process re-uses the latent heat of the vapors. The theoretical thermal efficiency of MVR can exceed that of a 100 effect evaporator, although there are a number of practical limitations, such as compressor and motor efficiencies which lower the achievable efficiency.

The mechanical device can be a centrifugal compressor for applications with high compression ratios, or a fan for lower compression ratios. For either device, the drive can be an electric motor, steam turbine, internal combustion engine or gas turbine.

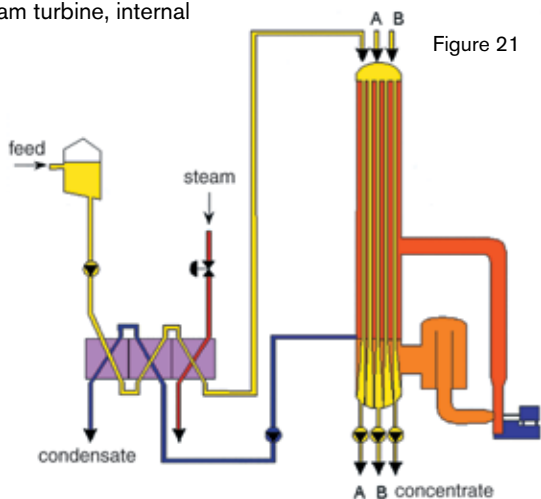

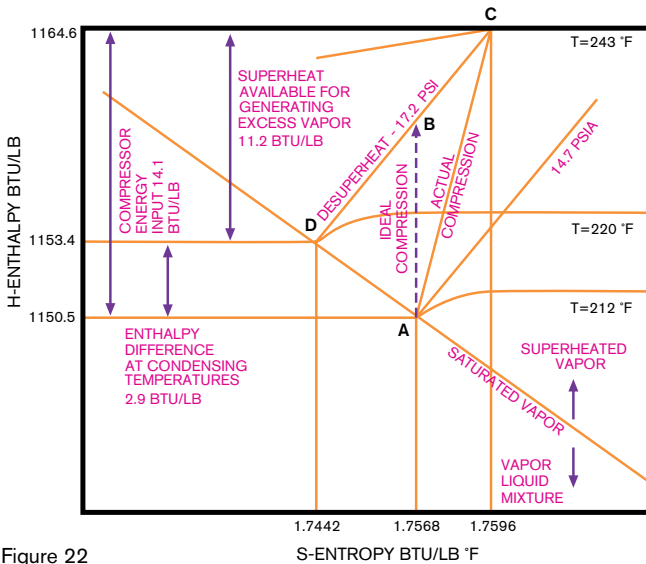

Figure 22

Thermodynamics of MVR

The process is best explained by reference to the Mollier—enthalpy/entropy diagram for steam (Figure 22).

The vapor evaporated from the product is represented on the Mollier diagram at point A. The actual values in US and metric units are presented on Table 1a and 1b. The vapor enters the compressor at point A. The vapor is then compressed to the higher pressure, at constant entropy at point B. The compressor, which in this case is a fan, has inefficiencies which results in an increase in entropy above that of the entropy at inlet. This is represented by point C. Vapor at point C is at the required pressure for the steam jacket of the condenser. However, it is superheated and must be cooled in order to condense in the evaporator. This cooling can be performed on the heat transfer surface of the evaporator. However, since desuperheating HTC's are usually low, the desuperheating is usually performed by the introduction of a spray of condensate into the vapor duct. This condensate vaporizes as the vapor is cooled back to the saturation temperature, and generates more vapor. This condition is represented by point D. At this point most of the vapor is condensed in the evaporator. However, there is an excess of vapor, which is required for heat loss and/or preheat duties. Any balance is condensed or vented.

PROPERTIES OF WATER VAPOR			
Pressure-PSIA	14.7	17.2	17.2
State	Saturated	Saturated	Superheated
Temperature °F	212	220	243
H-Enthalpy Vapor BTU/LB	1150.5	1153.4	1164.6
Latent Heat BTU/LB	970.3	965.2	–
H-Enthalpy Liquid BTU/LB	180.2	188.2	–
S-Enthalpy BTU/LB °F	1.7568	1.7442	1.7596

Table 1a. Properties of Water Vapor.

PROPERTIES OF WATER VAPOR			
Pressure-BAR	1	1.17	1.17
State	Saturated	Saturated	Superheated
Temperature °C	100	104	117
H-Enthalpy Vapor Kcals/Kg	639.1	640.8	647.0
Latent Heat Kcals/Kg	539.0	536.2	–
H-Enthalpy Liquid Kcals/Kg	100.1	104.6	–
S-Enthalpy Kcals/Kg °C	1.7568	1.7442	1.7596

Table 1b. Properties of Water Vapor.

In this example, the heat required to evaporate the water is 970.3 Btu (539.0 Kcals). However the compressor input is only 14.1 Btu (7.8 Kcals), with motor and gearbox losses increasing this to 14.7 Btu (8.16). The equivalent economy is 66 to 1.

It should be noted that pressure losses through the evaporator ducting, calandria and separator must be absorbed. This can be achieved by either a higher boost from the compressor at a higher power, or by accepting a lower temperature difference and increasing the surface area of the calandria.

Types of Compression Equipment

To a large extent, the development of this technology has been guided by the capabilities of the various types of compressors. The key to the design is the temperature difference that is available for the evaporator. Table 2 shows the temperature difference for various compression ratios at two different boiling temperatures. It is this temperature difference that is available as the driving force for evaporator, less a small amount required in the form of lost pressure around the system. The original MVR systems used compressors with compression ratios of about 1.4, which limited the available temperature difference to 13 to 18°F (7 to 10°C). This limits the MVR to single effect operation. More advanced centrifugal compressors were developed in the 1970s, which provided compression ratios of approximately 2. This provided a much higher temperature difference, which allowed operation with 2 and 3 effects. This reduces the flow to the compressor and increases the operating efficiency.

COMPRESSION RATIO	SATURATED ΔT AT BOILING TEMPERATURES			
	130°F	55°C	212°F	100°C
1.2	6.9	3.8	9.3	5.2
1.4	12.9	7.2	17.5	9.7
1.6	18.2	10.1	24.7	13.7
1.8	23.0	12.8	31.2	17.3
2.0	27.3	15.1	37.2	20.7

Table 2. Saturated ΔT at Various Compression Ratios, °F and °C.

A number of evaporators were built with the higher compression systems in multi-effect mode. Unfortunately, the reliability of the compressors became a problem. Because the compressor operates at high speed, it has to be protected from impingement of water droplets. This usually requires a mist eliminator in the separator, followed by a superheater. Any solids carryover will have a detrimental effect on the compressor. In addition, the designer must take care to prevent unstable compressor operation (surging). While the majority of the compressors functioned well, there were a few catastrophic compressor failures. These failures caused engineers to review alternative equipment.

The answer to the compressor problem was to use a fan. This equipment operates at a lower speed and is less vulnerable to damage from droplets. Fans are also far less likely to surge. When operated with a variable frequency drive, the fans

provide far greater flexibility than compressors. The only disadvantage to the fan is that compression ratios are limited to about 1.45. This results in a low available temperature difference and therefore a high heat transfer area. However, the energy efficiency of such systems is very high with the equivalent of 55 effects achievable for many duties.

Power Requirements

The compressor power requirements to evaporate 1000 lb/h (454 kg/h) of steam at various compression ratios and temperatures are shown in Tables 3a and 3b. Similar data for fans are shown in Tables 4a and 4b. These data correspond quite well with installed MVR systems.

A more detailed comparison between three actual systems is shown in Table 5. The more energy efficient system is the single effect fan with a low compression ratio. However, the low temperature difference will result in high heat transfer area in the calandria. In most cases the added capital cost will be justified by lower operating costs.

COMPRESSORS								
Boiling Temp 130°F			Boiling Temp 170°F			Boiling Temp 212°F		
CR	ΔT	kw	CR	ΔT	kw	CR	ΔT	kw
1.3	10.00	7.0	1.3	11.65	7.5	1.3	13.53	7.9
1.4	12.91	9.1	1.4	15.03	9.7	1.4	17.47	10.3
1.6	18.21	12.9	1.6	21.23	13.8	1.6	24.69	14.7
1.8	22.98	16.5	1.8	26.81	20.0	1.8	31.20	18.7
2.0	27.31	19.8	2.0	31.89	21.1	2.0	37.16	22.5
2.2	31.30	22.9	2.2	36.57	27.2	2.2	41.31	24.9

Table 3a. Power Vs ΔT for Centrifugal Compressors Based on 1000 lb/h of Steam Evaporated.

COMPRESSORS								
Boiling Temp 55°C			Boiling Temp 77°C			Boiling Temp 100°C		
CR	ΔT	kw	CR	ΔT	kw	CR	ΔT	kw
1.3	5.55	15.4	1.3	6.47	16.4	1.3	7.51	17.5
1.4	7.17	20.0	1.4	8.35	21.3	1.4	9.71	22.7
1.6	10.11	28.5	1.6	11.79	30.4	1.6	13.71	32.4
1.8	12.77	36.3	1.8	14.89	38.7	1.8	17.33	41.3
2.0	15.17	43.5	2.0	17.71	46.4	2.0	20.64	49.4
2.2	17.39	50.3	2.2	20.37	53.6	2.2	22.95	57.1

Table 3b. Power Vs ΔT for Centrifugal Compressors Based on 454 kg/h of Steam Evaporated.

Small MVR Evaporators

For small systems, rotary blowers were occasionally specified in an attempt to make MVR economic at evaporation capacities less than 15,000 lb/h (7000 kg/h). While there were cost savings, there were also reliability problems with this equipment for this particular application. The conclusion remained that for small systems, it is usually best to use steam driven evaporators.

FANS								
Boiling Temp 130°F			Boiling Temp 170°F			Boiling Temp 212°F		
CR	ΔT	kw	CR	ΔT	kw	CR	ΔT	kw
1.1	3.59	2.22	1.1	4.17	2.38	1.1	4.85	2.54
1.2	6.91	4.31	1.2	8.04	4.60	1.2	9.34	4.92
1.3	10.00	6.28	1.3	11.65	6.71	1.3	13.53	7.15

Table 4a. Power Vs ΔT for Fans Based on 1000 lb/h of Steam Evaporated.

FANS								
Boiling Temp 55°C			Boiling Temp 77°C			Boiling Temp 100°C		
CR	ΔT	kw	CR	ΔT	kw	CR	ΔT	kw
1.1	1.99	4.90	1.1	2.32	5.22	1.1	2.69	5.58
1.2	3.84	9.49	1.2	4.47	10.12	1.2	5.19	10.81
1.3	5.56	13.81	1.3	6.47	14.75	1.3	7.52	15.73

Table 4b. Power Vs ΔT for Fans Based on 454 kg/h of Steam Evaporated.

	SINGLE EFFECT FAN	DOUBLE EFFECT CENTRIFUGAL	TRIPLE EFFECT CENTRIFUGAL
Compression Ratio	1.2	1.6	2.0
Total ΔT Available	6.9°F (3.8°C)	18.2°F (10.1°C)	27.3°F (15.2°C)
Vapor to Compressor	60,000 lb/h (27,300 kg/h)	30,000 lb/h (13,650 kg/h)	20,000 lb/h (9,090 kg/h)
Total Power Kw	280	390	400
Equivalent Steam	870 lb/h (395 kg/h)	1315 lb/h (600 kg/h)	1347 lb/h (612 kg/h)
Equivalent Steam Economy	69	45.6	44.5
Average ΔT Per Effect Before Losses	6.9°F (3.8°C)	9.1°F (5.1°C)	9.1°F (5.1°C)
NOTE: In this example, the fan horsepower is lower than either of the centrifugal designs, but the lower ΔT required the greater the surface area.			

Table 5. Comparison of Typical MVR Designs — Approximate boiling temperature — 130°F (55°C) evaporation rate—60,000 lb/hr (27,000 kg/h).

Evaporators for Industrial and Chemical Applications

The APV range of evaporators covers many duties in the concentration of chemicals and industrial products, with both film and forced circulation systems being available as required.

Film evaporators are used when there is little or no risk of fouling of the heating surfaces. Where such a risk is present, forced circulation units are recommended. All designs are suitable for multi-effect evaporation. At low concentrations, mechanical vapor recompression can be employed.

After selecting the type of evaporator required for a particular duty, the most important factor is the selection of the materials of construction. Many duties can be handled with 316 stainless steel. For some applications where chloride ions are present, higher grades of stainless steel, such as 904L, can be an economic selection.

Certain products are so corrosive that they cannot be processed in conventional metals. As an example, concentration of a sulfuric acid solution of up to 50% at 302°F (150°C) would call for main plant items of filament wound fiberglass reinforced epoxy resin, and heating and cooling surfaces of impervious graphite. If the sulfuric acid solution is between 50 and 80% with temperatures up to 230°F (110°C), main plant items should be lead-lined mild steel protected with refractories or carbon tiles. Heat transfer surfaces again would be of impervious graphite. A typical system (Figure 23) is shown here. It should be noted that APV does not market non-metallic evaporators.



Figure 23

Titanium Sulfate

The production of titanium dioxide pigments involves reaction between sulfuric acid and the ore which contains iron, titanium sulfate and other compounds.

After pretreatment, which includes the crystallization of iron as ferrous sulfate, the liquor is heated and hydrolyzed to precipitate titanium dioxide. Prior to this operation, the concentration of liquor has to be adjusted by the evaporation of water. It is essential that this process takes place in an evaporator with short heat contact times in order to avoid the premature hydrolysis that occurs with prolonged heating, which subsequently causes fouling of the heat surface and blockage of the tubes. Although the liquor contains a high proportion of sulfuric acid, the presence of other ions in solution may inhibit corrosion, so that copper often can be used for heat transfer surfaces. Titanium is another material used for this application.

Generally, single or multiple effect rising film evaporators are used for this duty, the number of effects being determined by throughput and by assessing the cost of operation against the increase in capital required for additional equipment.

In some cases, it is economically attractive to operate the evaporator as a single effect unit at atmospheric pressure using the vapor given off for preheating. The liquor is discharged at a temperature in excess of 212°F (100°C), reducing the subsequent thermal load at the hydrolysis stage.

Phosphoric Acid

Phosphoric acid can be produced by the digestion of phosphate rock (calcium phosphate and fluoride among others) in sulfuric acid, better known as the “wet process” acid. Since calcium sulfate normally is a constituent, scaling must be considered. Phosphate rock varies in composition, and in general, periodic cleaning is required even in forced circulation evaporators.

Sulfuric acid plants often are located along coastal areas, and a further problem in concentration stems from the use of sea water in the direct contact condensers. With silica present in the phosphate rock, fluorine reacts to form hydrofluorosilicic acid (H_2SiF_6) which in turn, forms a sodium salt from the NaCl. Sodium fluorosilicic can block the condensers.

Ammonium Nitrates

This material has several significant properties:

- Low viscosity which allows it to be concentrated to 99+% w/w when it is prilled.
- Above 95%, ammonium nitrate has an extremely high boiling point elevation which requires exceedingly high steam pressures for heating. This presents considerable mechanical problems.
- Any organic impurity has the potential for explosion, such that extra low carbon stainless steels must be used for heat transfer surfaces, and the use of mineral oils for heating is excluded.

The type of evaporator best suited for ammonium nitrate depends upon the initial and final concentrations. For the range below 70% and up to 80-85%, rising film multi-effect evaporator units have been used successfully. For 80-96% concentrations, conventional falling film systems have been employed. Above 96%, however, falling film with a heated air sweep would be used due to partial pressure conditions. In areas of relatively low humidity, 99+% water to water can be achieved.

Ammonium Sulfate

Ammonium sulfate is used in battery spacer plate production and also has been crystallized. In this process, small but regular sized crystals are mixed with a PVC type plastic and dissolved out of the final sheet which then is used as spacer plate. Stainless steel has been successfully employed as the material of construction.

Barium Salts

The production of barium salt involves the use of sodium sulfide, a material which closely resembles caustic soda in both physical and corrosive properties. It generally is concentrated in a high vacuum crystallizer for the production of barium hydroxide with rubber lined mild steel being used as the material of construction due to corrosion considerations. With liquid temperatures below 72°F, two hydrates, mono and penta, can be produced on separate flakers.

Glycerine

Sweet water glycerine containing no NaCl has been handled in simple stainless steel film evaporators by salt and oleo chemical producers. For sodium chloride bearing liquors as in spent lye for industrial detergent and soap manufacture, cupronickel alloys must be used.

When the glycerine is contaminated with salt, the special application of forced circulation crystallizers has been employed for the recovery of the glycerine liquor and separation of the NaCl salts.

Caustic Soda

The most common process for the manufacture of caustic soda is the electrolysis of sodium chloride brine. The electrolytic processes produce a caustic soda solution that has to be concentrated by evaporation. This evaporation process is difficult since caustic soda solutions have a high boiling point elevation (BPE).

At 50% concentration the BPE is about 80°F (45°C). This limits the number of effects usually to three, with the evaporator operated in reverse flow so that the highest concentration is on the first effect. This effect will typically operate at over 260°F (125°C).

An additional problem is that at high temperature, caustic soda solutions corrode stainless steel. The first and second effect calandrias are usually fabricated in nickel, which is resistant to corrosion. The third effect can be Avesta 254SLX, which is far less expensive than nickel. The vapor side of the evaporator can be 304 stainless steel and sometimes carbon steel.

Tubular falling film evaporators have been the standard for this application. In recent years, APV has employed a plate evaporator for caustic soda. The plate employs nickel welded pairs and proprietary gaskets. The APV design for caustic soda has proven to be the best solution to minimize nickel pickup, which is important to the bleach manufacturing industry.

Solvent Recovery

Not all evaporation processes are limited to the removal of water. Some applications require the concentration of a solution of solids and organic solvents. Organic solvents are frequently used for the extraction of products from raw materials or fermented broths. The solvent then has to be removed from the extracted product. A typical application would be the evaporation of acetone from vegetable oils.

For these types of duties it is necessary to use explosion proof electrical equipment and intrinsically safe instrumentation. It is also necessary to observe environmental regulations particularly since some solvents, such as methylene chloride are classified as regulated compounds with stringent discharge limits to both air and water. The system must be designed without leaks and with conservation devices on all possible vents. For evaporator selection, the normal guidelines that are used for the evaporator of water remain the same. The only major difference is that HTC's are significantly lower for organic solvents.

A solvent evaporator (Figure 24) is shown below.

Figure 24



Waste Water Evaporators

As the world has become more concerned about the environment, there has been an increase in the application of evaporator systems to waste water treatment. These types of evaporators essentially reduce the volume of the waste by removing and recovering most of the water in the waste. In some applications, the concentrate contains product of value, which can be sold or further processed in a dryer to a solid product. In cases where the product has no value, the concentrate can be dried and the resulting product buried in a landfill. Since the condensate from these evaporators is usually quite pure, the water that is recovered can be used as boiler feed, as rinse fluid for cleaning or merely disposed into the sewer or directly into a river.

As with the processing of any waste product, there are usually severe cost restraints since, unless forced by regulation, few organizations wish to spend valuable capital on waste treatment processes. The equipment therefore has to have both low capital and operating costs.

The key points in the design of a waste water evaporator are:

- Flow rate: this is usually quite high for these evaporators
- Solids concentration in the feed: this is usually quite low
- Product concentration and the viscosity of the product at that concentration
- Problems with possible volatile components in the feed
- Corrosive nature of the feed: since many waste water evaporators have high concentration ratios, the effects of corrosion can be enhanced in the final stages of evaporation
- Potential for fouling: this can be very serious in many cases.
- Boiling point elevation

Because of the large duties, mechanical vapor recompression (MVR) evaporation is usually the choice. However if boiling point elevation is high, the MVR would be limited to the pre concentration and would require a separate steam powered single or multi-effect finisher to arrive at the final concentration. The presence of volatile components in the feed, such as ethanol, can also limit the application of MVR. In this case, it is usually necessary to remove the volatile components in a stripper column. In a multi-effect evaporator the stripper column can be placed between effects, which allows recovery of the heat needed to operate the stripper.

Brewery/Distillery Effluents

The effluents from brewery and distillery plants are often processed with evaporators to recover the water and produce a concentrated syrup, which can be sold in liquid form, or added to the spent grains prior to drying. In this case the solids have value as animal food.

Both MVR and multi-effect evaporators have been used for these types of duty. Normally falling film tubular calandrias would be used for the pre evaporator with forced circulation plate or tubular evaporators as the finisher. As in most applications the viscosity of the product at the evaporation temperature controls the point at which the material has to be processed in a forced circulation system. An MVR stillage evaporator (Figure 25) is shown below.

The problem with these applications is that the product, which can be called stillage, spent wash, spent grains or pot ale, is extremely variable. In particular the viscosity characteristics of the concentrated liquids depend on the raw material grain. Waste water produced from plants using corn (maize) as the feed stock are relatively easy to process. However, waste water from plants which use wheat or barley as the feedstock will be far more viscous at elevated concentrations. In some cases, the viscosity characteristics will be so bad that even a forced circulation evaporator will only be able to concentrate to 35% solids. This usually means treating the feed with enzymes prior to evaporation so that a solids concentration of 45% solids can be achieved.

The higher the viscosity, the more frequently the evaporator will have to be cleaned. The accepted run time in the industry is 6 to 8 days. To achieve this, it is usually necessary to provide high recirculation around the calandrias to provide a high wetting rate and prevent burn on. On the finisher, it is occasionally necessary to provide duplex heat exchangers, so that one can be cleaned while the other is in operation.



Figure 25

Black Liquor

Black liquor is a caustic waste water generated at paper plants. The quantity of this material produced is large, and some of the largest evaporator applications are with black liquor. An evaporator, designed by APV, for a feed rate of 170 ton/h (Figure 26), is shown here.



Figure 26

Typically black liquor contains about 3% solids, of which about half is caustic soda. The presence of this caustic soda results in quite high boiling point elevation as the concentration increases. This places some restrictions on the application of MVR, so that most black liquor evaporators are multi-effect.

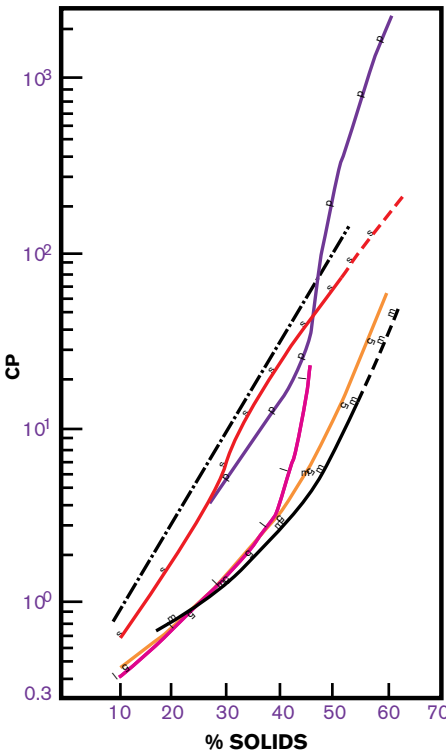

This waste water also varies from plant to plant, and the concentrate properties are extremely dependent on the feedstock. The product viscosity (Figure 27) is plotted against % solids for different types of feedstock. In some cases there is a tenfold difference in viscosity.

VISCOSITY OF BLACK LIQUORS AT 90°C

- m BAMBOO (KRAFT)
- 5 PINE (1)
- l EUCALYPTUS (PREHYDROLYSIS KRAFT)
- s BAGASSE (KRAFT)
- p BAGASSE (SODA)
- STRAA (KRAFT) (3)
- NEWTONIAN
- · — NON-NEWTONIAN

Figure 27

Evaporator Control

The control of most chemical/industrial evaporator systems is quite simple. However, with hygienic evaporators the control is somewhat more complicated due to the need to start up, operate, shut down and then clean at quite frequent intervals. As a result sophisticated control is more likely to be needed on hygienic systems.

On almost all evaporation systems there are only two basic objectives:

- To concentrate a liquid to a pre-defined solids content
- To process a pre-defined feed rate of raw material

Theoretically this can be achieved with only two control loops. However in practice there are additional loops for level control and pressure control.

Product concentration has been measured using refractive index, density and viscosity techniques. Over the last ten years, the use of mass flow meters for density measurement has become the standard. This type of meter provides an accurate measurement (usually out to the 4th decimal place) of both flow and density. The density measurement, which is easily converted to a solids content, can then be used to control either product removal rate from the evaporator, steam flow, or feed flow.

There are two techniques used to control evaporators, and the choice is based on the design of the evaporator. In applications where liquid recirculation is required to maintain sufficient wetting in the final stage of the evaporator, the product concentration control is simple and accurate. The procedure is to set the steam flow rate at the design value, remove product based on density in the recirculation loop, and adjust the feed flow to maintain liquid levels in the evaporator. When a higher throughput is required, then the steam rate is increased. This technique provides excellent control of the product concentration with conventional analog controllers.

For heat sensitive products, it is best to avoid recirculation whenever possible. In the case of once-through-flow in the final stage, there is no recirculation loop in which to install the transmitter and to delay discharge of product when not on specification. In this case, the method is to set the feed flow rate to the desired value and then change the energy input to produce the product concentration required. The energy input may be the steam rate or the power into the MVR. This technique does not control product quality particularly accurately, since response is slow. However it is satisfactory for most purposes, and the user can always apply more sophisticated PLC control when necessary.

Almost all evaporators will have to be cleaned at some time. Some chemical evaporators may run for months between cleaning cycle. Also with non-hygienic duties, the only requirement is to clean the heat transfer surface sufficiently to restore design performance.

In the case of hygienic evaporators, the concern is not only plant operation, but also contamination from bacteria. Typically, a hygienic evaporator will be cleaned every day.

Dairy evaporators, which are designed and constructed to 3A standards, are subject to one of the highest cleaning standards. The inspector will expect that the equipment be cleaned completely with no residue left on any surfaces. The potential labor costs to start up, shut down and go through a complex cleaning cycle, on a daily basis, are very high. A fully automatic system is therefore required to perform all these operations. These functions are ideally performed by a PLC.

Usually PLC control offers maximum throughput, maximum efficiency, constant product, and minimizes startup and shutdown times. It also minimizes CIP time while maximizing CIP effectiveness. Most PLCs offer historical data collection so that management can continue to improve and maximize the evaporator system's performance.

Preassembled Evaporators

Almost all small evaporators and certain medium size evaporators can be preassembled in the shop prior to shipment. The advantages of this approach are given below:

- Assembly of equipment, piping and wiring in the shop is easier and less expensive than assembly in the field.
- The time to install the equipment in the field is considerably reduced. This reduces the disruption to other plant operation.
- The overall cost of the project is reduced.

A small preassembled Paravap evaporator (Figure 28) can be fully assembled on a stainless steel skid complete with control panel and motor starters. The on site installation takes hours rather than days.

A larger system (Figure 29), like this double effect forced circulation system, was too large to ship as a single skid so it was assembled of two skids in the shop and partially broken down for shipment.

The maximum size of equipment that can be shipped over the roads is about 12ft. (3.65m) by 14ft. (4.25m) by 100ft. (30m). However, it is still possible to preassemble large systems in the shop. The systems are then match marked and disassembled for shipment. Assembly on site is a relatively simple procedure. However, preassembly becomes less attractive economically as the size of the systems increases.



Figure 28



Figure 29

The Production of High Quality Juice Concentrates

Changes in our lifestyles over the past twenty years have been dramatic. Not the least of these changes has been our dietary habits — influenced not only by our perceived values of diet related to general health, but also by changes in food processing technology across a very wide spectrum.

Storage of fruit before processing begins a gradual process of change from the fresh product. Breaking or peeling of fruit releases some of the natural essences even at atmospheric temperatures, and natural biochemical processes commence which affect color and enzyme components, pectin and other characteristic properties of the fruit.

The aim of food manufacturers is to produce a juice or concentrate which closely resembles the original 'fresh from the fruit'. Of all the ways we can influence this, time and temperature are paramount.

Evaporation

Evaporation is by far the most prevalent process used for the production of concentrates. It provides a highly energy efficient means of removing water and is well suited to recovering 'essence' components during the process.

The problem for the equipment designer has always been one of providing a cost-effective system having low energy requirements, with acceptable concentrate quality, and along the way collecting essences in sufficiently useable quantity and quality.

The ultra short time FFPE (Falling Film Plate Evaporator) was introduced by APV in the early 1970's. The patent covered a two-plate per unit design — one steam and one product — in which the product could be fed first to one half of the plate then returned in series to the other side of the plate for improved wetting without recirculation.

The most difficult design area of any falling film evaporator is the liquid distribution system which ensures an even flow of liquid over the total evaporating surface. This was achieved by an ingenious three stage process involving small pressure losses and flash vapor.

Time/temperature are markedly influenced by single pass operation in an evaporator by avoiding the use of recirculation. In the FFPE, with its two-stage design and longer flow path, recirculation is avoided on all triple effect and over systems, and even on double-effect under some temperature conditions.

This design could still be improved, however, and the FFSR (Falling Film Long Evaporator) is the current development in the plate evaporator technology. This is a divided plate design like the FFPE, but has a 50% longer flow path. This creates thinner films off the plate, with improved wetting characteristics. A single falling film plate effect, less than 78"/2 meters in plate length, is equivalent to one pass in a tube 630"/16 meters long.

A special arrangement of the support pipes improves cleaning in place (CIP) of the plate, by using a disparate positioning on the plate. The FFLE is current state-of-the art technology, producing concentrates of high quality on a wide range of juices.

Essence Recovery

Distillation

Essences can be recovered by full distillation techniques with high yield on products less sensitive to temperature, such as apple and grape. The distillation aroma recovery process is described in the following case study, where its application in a special configuration on grape juice concentration combines a number of new technological features.

Partial Condensation

The loss of, or damage to, essences from fruit commences at the moment of picking. It increases after extraction, and with any form of heating and flash vapor release. The partial condensation aroma recovery unit has provided effective and economic ways of capturing the elusive flavor components for storage and re-use with reconstituted juices or for use in the cosmetic and other industries.

The partial condensation aroma recovery unit makes use of the fact that if juice is heated in a closed system, then released into a region of pressure below the saturation point, flash vapors released will strip aroma compounds from the liquid phase into volatiles which travel with the vapors. There will be some essence components which do not volatilize and remain in the juice throughout the process, but a substantial percentage of the aromas is liberated.

If the vapors from the first 'strip' are withdrawn from the first stage of evaporation in a multi-effect system, they will be more than enough in quantity to ensure a high percentage recovery of aromas. These will go with the vapor to the heating side of the next evaporator effect to provide the energy for further evaporation. In the process, only part of the vapor is condensed. A portion, perhaps 10 or 15%, is allowed to pass through the heating side uncondensed, and then ducted to the aroma recovery system.

Because of the different boiling points of aroma compounds, most of the essences remain with the uncondensed portion. In the aroma recovery unit, a further selective condensing process takes place, which removes more of the water vapor to leave a concentrated essence. This essence is chilled and collected together with recovered components from a final vent scrubber system. It can then be stored for later use or added back to aseptically processed concentrate during the cooling stage.

The temperature at which the first strip takes place varies according to the fruit. Some tropical fruits, like pineapple, are more sensitive, and temperatures above 60°C should be avoided. For apple and less sensitive fruits, temperatures in the 80s or 90s can provide higher yields without thermal degradation of the essence.

Case Study

Concord grape presents its own special problems in concentration due to the high level of tartrates. These tartrates can crystallize out under certain temperature and concentration conditions with unhappy results in terms of length of run between cleanings.

A team of distillation and evaporation specialists used new and existing technology to develop a system to cope with these product characteristics and to produce quality essences with high yield. The key features of the final solution chosen were as follows:

- In order to keep temperatures above crystallization, the grape juice was concentrated using a reverse feed design, with dilute juice being directed to the low temperature effect first and leaving at the high temperature effect (Figure 30).
- In order to provide the quality enhancement and color benefits specified, an FFLE was selected in a three, four or five (Welch's) effect configuration. This ensured the shortest possible residence time during the initial stages of concentration, where tartrate crystallization can be more readily controlled.
- A tubular finisher evaporator was selected, designed specifically to deal with the problem area where concentrate is approaching the supersaturation point for tartrates.

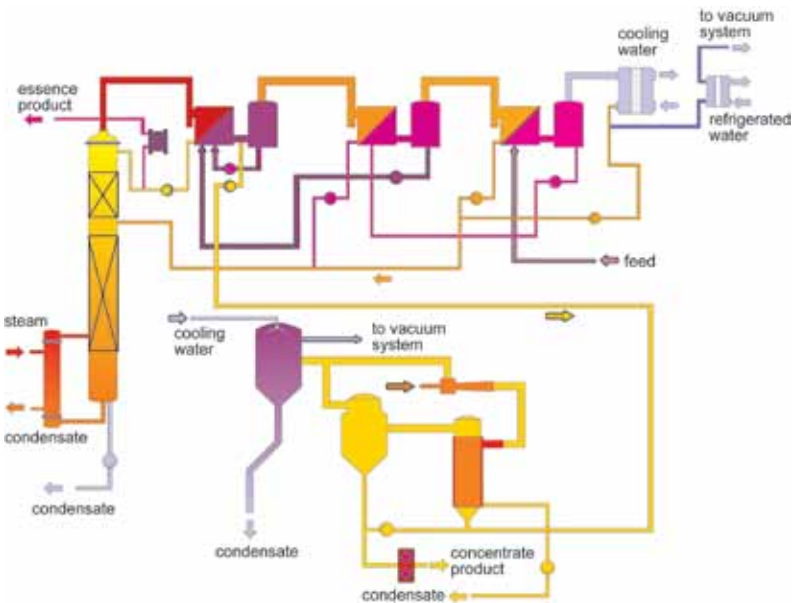

Figure 30. Flow diagram. Concord grape juice is extremely difficult to process due to the precipitation of tartrates during concentration. To keep temperatures above crystallization, as the grape juice is concentrated, a reverse feed design was selected, with dilute juice being directed to the low temperature effect first and leaving at the high temperature effect.

At the finisher level of concentration, it was no longer possible to operate at temperatures high enough to keep tartrates in solution. The designer therefore used the relatively larger effective diameter of a tube to advantage, by employing a forced circulation mode operating at only 120°F (50°C). This technique promoted larger crystal growth in the final concentrate. Tartrate crystal growth occurs more on crystals in suspension instead of on equipment. This promotes longer runs between cleaning. The forced circulation tubular design was well able to cope with the crystals on extended operating times, and the larger crystals were much easier to deal with at the separation stage.

A large distillation column was chosen to recover essences from the grape juice.

In the reverse feed system, most of the highly volatile essence components (methyl anthranilate being the key essence) were released in the initial stage of evaporation. When these condensates plus vents were taken into the column for stripping and rectification, a high yield of essence was guaranteed.

The key to the design was the use of essence-rich vapor discharge from the distillation column, directly into the steam side of the first effect FFLE, where it provided the total energy to drive the three- or four- effect preconcentrator evaporator using the evaporator as a condenser.

The first effect condensate now became the rich essence, and most of this was returned to the column as reflux. A small quantity of essence was removed and chilled, and later this was added back to the concentrate for quality enhancement.

In terms of energy efficiency, this plant (Figure 31) was a breakthrough in design of high quality concentrate-plus-essence systems.



Figure 31

Engineering Conversions

TO CONVERT FROM	TO	MULTIPLY BY
Heat Capacity		
Calories/(Gram) (°C)	Calories/(Gram) (Mole) (°C) BTU/(Pound) (°F)	Molecular Weight 1.0
Density		
Gram/Milliliter	Pounds/Gallon Pounds/Cubic Ft.	8.33 62.42
Thermal Conductivity		
Kilocalorie/(Hr) (m) (°C) Watt/(m) (°C)	Btu/(Hr) (Ft) (°F)	0.6719 0.5778
Viscosity		
Centistokes	Centipoise	Specific Gravity
Dynamic Viscosity		
Pound-Mass/(Ft) (Sec)	Centipoise	1488.2
Kinematic Viscosity		
Cm ² /Sec	Centistokes	100
Pressure		
KiloPascal Bar	psi	0.14504 14.504
Inches Hg Absolute Atmosphere Torr mm Hg	psia	0.4912 14.696 0.01908 0.01908
Enthalpy		
Calorie/Gram Work/Energy (Kilowatt) (Hr) (Horsepower) (Hr) Calorie	Btu/Pound-Mass Btu	1.8 3412.1 2544.4 0.003968
Heat Transfer Coefficient		
Kilocalorie/(Hr) (M ²) (°C) Watt/(cm ²)(°C)	Btu/(Hr)(Ft ²)(°F)	0.2048 1761.1

Properties of Saturated Steam Temperature Tables

TEMPERATURE		PRESSURE		VACUUM		SPECIFIC VOLUME		LATENT HEAT	
°F	°C	PSIA	BAR	In Hg	mm Hg	ft ³ /lb	m ³ /Kg	Btu/lb	Kcals/Kg
32	0.000	0.08859	0.00611	29.741	755.421	3304.7	206.544	1075.5	597.5
33	0.556	0.09223	0.00636	29.734	755.244	3180.7	198.794	1074.9	597.2
34	1.111	0.09600	0.00662	20.726	526.440	3061.9	191.369	1074.4	596.9
35	1.667	0.09991	0.00689	29.718	754.837	2948.1	184.256	1073.8	596.6
36	2.222	0.10395	0.00717	29.710	754.634	2839.0	177.438	1073.2	596.2
37	2.778	0.01815	0.00125	29.701	754.405	2734.4	170.900	1072.7	595.9
38	3.333	0.11249	0.00776	29.692	754.177	2634.2	164.638	1072.1	595.6
39	3.889	0.11698	0.00807	20.683	525.348	2538.0	158.625	1071.5	595.3
40	4.444	0.12163	0.00839	29.674	753.720	2445.8	152.863	1071.0	595.0
41	5.000	0.12645	0.00872	29.664	753.466	2357.3	147.331	1070.4	594.7
42	5.556	0.13143	0.00906	29.654	753.212	2274.4	142.150	1069.8	594.3
43	6.111	0.13659	0.00942	29.643	752.932	2191.0	136.938	1069.3	594.1
44	6.667	0.14192	0.00979	29.632	752.653	2112.8	132.050	1068.7	593.7
45	7.222	0.14744	0.01017	29.621	752.373	2037.8	127.363	1068.1	593.4
46	7.778	0.15314	0.01056	29.610	752.094	1965.7	122.856	1067.6	593.1
47	8.333	0.15904	0.01097	29.597	751.764	1896.5	118.531	1067.0	592.8
48	8.889	0.16514	0.01139	29.585	751.459	1830.0	114.375	1066.4	592.4
49	9.444	0.17144	0.01182	29.572	751.129	1766.2	110.388	1065.9	592.2
50	10.000	0.17796	0.01227	29.559	750.799	1704.8	106.550	1065.3	591.8
51	10.556	0.18469	0.01274	29.545	750.443	1645.9	102.869	1064.7	591.5
52	11.111	0.19165	0.01322	29.531	750.087	1589.2	99.325	1064.2	591.2
53	11.667	0.19883	0.01371	29.516	749.706	1534.8	95.925	1063.6	590.9
54	12.222	0.20625	0.01422	29.501	749.325	1482.4	92.650	1063.1	590.6
55	12.778	0.21392	0.01475	29.486	748.944	1432.0	89.500	1062.5	590.3
56	13.333	0.22183	0.01530	29.470	748.538	1383.6	86.475	1061.9	589.9
57	13.889	0.23000	0.01586	29.453	748.106	1337.0	83.563	1061.4	589.7
58	14.444	0.23843	0.01644	29.436	747.674	1292.2	80.763	1060.8	589.3
59	15.000	0.24713	0.01704	29.418	747.217	1249.1	78.069	1060.2	589.0
60	15.556	0.25611	0.01766	29.400	746.760	1207.6	75.475	1059.7	588.7
61	16.111	0.26538	0.01830	29.381	746.277	1167.6	72.975	1059.1	588.4
62	16.667	0.27494	0.01896	29.362	745.795	1129.2	70.575	1058.5	588.1
63	17.222	0.28480	0.01964	29.341	745.261	1092.1	68.256	1058.0	587.8
64	17.778	0.29497	0.02034	29.321	744.753	1056.5	66.031	1057.4	587.4

TEMPERATURE		PRESSURE		VACUUM		SPECIFIC VOLUME		LATENT HEAT	
°F	°C	PSIA	BAR	In Hg	mm Hg	Ft ³ /lb	m ³ /Kg	Btu/lb	Kcals/Kg
65	18.333	0.30545	0.02107	29.299	2.02062	1022.1	63.881	1056.9	587.2
66	18.889	0.31626	0.02181	29.277	2.01910	989.0	61.813	1056.3	586.8
67	19.444	0.32740	0.02258	29.255	2.01759	957.2	59.825	1055.7	586.5
68	20.000	0.33889	0.02337	29.231	2.01593	926.5	57.906	1055.2	586.2
69	20.556	0.35073	0.02419	29.207	2.01428	896.9	56.056	1054.6	585.9
70	21.111	0.36292	0.02503	29.182	2.01255	868.4	54.275	1054.0	585.6
71	21.667	0.37549	0.02590	29.157	2.01083	840.9	52.556	1053.5	585.3
72	22.222	0.38844	0.02679	29.130	2.00897	814.3	50.894	1052.9	584.9
73	22.778	0.40177	0.02771	29.103	2.00710	788.8	49.300	1052.4	584.7
74	23.333	0.41550	0.02866	29.075	2.00517	764.1	47.756	1051.8	584.3
75	23.889	0.42964	0.02963	29.027	2.00186	740.3	46.269	1051.2	584.0
76	24.444	0.44420	0.03063	29.017	2.00117	717.4	44.838	1050.7	583.7
77	25.000	0.45919	0.03167	28.986	1.99903	695.2	43.450	1050.1	583.4
78	25.556	0.47461	0.03273	28.955	1.99690	673.9	42.119	1049.5	583.1
79	26.111	0.49049	0.03383	28.923	1.99469	653.2	40.825	1049.0	582.8
80	26.667	0.50683	0.03495	28.889	1.99234	633.3	39.581	1048.3	582.4
81	27.222	0.52364	0.03611	28.855	1.99000	614.1	38.381	1047.8	582.1
82	27.778	0.54093	0.03731	28.820	1.98759	595.6	37.225	1047.3	581.8
83	28.333	0.55872	0.03853	28.784	1.98510	577.6	36.100	1046.7	581.5
84	28.889	0.57702	0.03979	28.746	1.98248	560.3	35.019	1046.1	581.2
85	29.444	0.59583	0.04109	28.708	1.97986	543.6	33.975	1045.6	580.9
86	30.000	0.61518	0.04243	28.669	1.97717	527.5	32.969	1045.0	580.6
87	30.556	0.63507	0.04380	28.628	1.97434	511.9	31.994	1044.4	580.2
88	31.111	0.65551	0.04521	28.587	1.97152	496.8	31.050	1043.9	579.9
89	31.667	0.67653	0.04666	28.544	1.96855	432.2	27.013	1043.3	579.6
90	32.222	0.69813	0.04815	28.500	1.96552	468.1	29.256	1042.7	579.3
91	32.778	0.72032	0.04968	28.455	1.96241	454.5	28.406	1042.2	579.0
92	33.333	0.74313	0.05125	28.408	1.95917	441.3	27.581	1041.6	578.7
93	33.889	0.76655	0.05287	28.361	1.95593	428.6	26.788	1041.0	578.3
94	34.444	0.79062	0.05453	28.312	1.95255	416.3	26.019	1040.5	578.1
95	35.000	0.81534	0.05623	28.261	1.94903	404.4	25.275	1039.9	577.7
96	35.556	0.84072	0.05798	28.210	1.94552	392.9	24.556	1039.3	577.4
97	36.111	0.86679	0.05978	28.157	1.94186	381.7	23.856	1038.8	577.1
98	36.667	0.89356	0.06162	28.102	1.93807	370.9	23.181	1038.2	576.8
99	37.222	0.92103	0.06352	28.046	1.93421	360.5	22.531	1037.6	576.4

TEMPERATURE		PRESSURE		VACUUM		SPECIFIC VOLUME		LATENT HEAT	
°F	°C	PSIA	BAR	In Hg	mm Hg	Ft ³ /lb	m ³ /Kg	Btu/lb	Kcals/Kg
100	37.778	0.94924	0.06546	27.989	1.93028	350.4	21.900	1037.1	576.2
101	38.333	0.97818	0.06746	27.930	1.92621	340.6	21.288	1036.5	575.8
102	38.889	1.00789	0.06951	27.869	1.92200	331.1	20.694	1035.9	575.5
103	39.444	1.03838	0.07161	27.807	1.91772	322.0	20.125	1035.4	575.2
104	40.000	1.06965	0.07377	27.743	1.91331	313.1	19.569	1034.8	574.9
105	40.556	1.10174	0.07598	27.678	1.90883	304.5	19.031	1034.2	574.6
106	41.111	1.1347	0.07826	27.611	1.90421	296.18	18.511	1033.6	574.2
107	41.667	1.1684	0.08058	27.542	1.89945	288.11	18.007	1033.1	573.9
108	42.222	1.2030	0.08297	27.417	1.89083	280.30	17.519	1032.5	573.6
109	42.778	1.2385	0.08541	27.400	1.88966	272.72	17.045	1031.9	573.3
110	43.333	1.2750	0.08793	27.325	1.88448	265.39	16.587	1031.4	573.0
111	43.889	1.3123	0.09050	27.249	1.87924	258.28	16.143	1030.8	572.7
112	44.444	1.3505	0.09314	27.172	1.87393	251.38	15.711	1030.2	572.3
113	45.000	1.3898	0.09585	27.092	1.86841	244.70	15.294	1029.6	572.0
114	45.556	1.4299	0.09861	27.001	1.86214	238.22	14.889	1029.1	571.7
115	46.111	1.4711	0.10146	26.926	1.85697	231.94	14.496	1028.5	571.4
116	46.667	1.5133	0.10437	26.840	1.85103	225.85	14.116	1027.9	571.1
117	47.222	1.5566	0.10735	26.752	1.84497	219.94	13.746	1027.3	570.7
118	47.778	1.6009	0.11041	26.662	1.83876	214.21	13.388	1026.8	570.4
119	48.333	1.6463	0.11354	26.569	1.83234	208.66	13.041	1026.2	570.1
120	48.889	1.6927	0.11674	26.475	1.82586	203.26	12.704	1025.6	569.8
121	49.444	1.7403	0.12002	26.378	1.81917	198.03	12.377	1025.0	569.4
122	50.000	1.7891	0.12339	26.279	1.81234	192.95	12.059	1024.5	569.2
123	50.556	1.8390	0.12683	26.177	1.80531	188.03	11.752	1023.9	568.8
124	51.111	1.8901	0.13035	26.073	1.79814	183.24	11.453	1023.3	568.5
125	51.667	1.9428	0.13399	25.966	1.79076	178.60	11.163	1022.7	568.2
126	52.222	1.9959	0.13765	25.858	1.78331	174.09	10.881	1022.2	567.9
127	52.778	2.0507	0.14143	25.746	1.77559	169.72	10.608	1021.6	567.6
128	53.333	2.1068	0.14530	25.632	1.76772	165.47	10.342	1021.0	567.2
129	53.889	2.1642	0.14926	25.515	1.75966	161.34	10.084	1020.4	566.9
130	54.444	2.2230	0.15331	25.395	1.75138	157.33	9.833	1019.8	566.6
131	55.000	2.2830	0.15745	25.273	1.74297	153.44	9.590	1019.3	566.3
132	55.556	2.3445	0.16169	25.148	1.73434	149.66	9.354	1018.7	565.9
133	56.111	2.4074	0.16603	25.020	1.72552	145.98	9.124	1018.1	565.6
134	56.667	2.4717	0.17046	24.889	1.71648	142.41	8.901	1017.5	565.3

TEMPERATURE		PRESSURE		VACUUM		SPECIFIC VOLUME		LATENT HEAT	
°F	°C	PSIA	BAR	In Hg	mm Hg	Ft ³ /lb	m ³ /Kg	Btu/lb	Kcals/Kg
135	57.222	2.5375	0.17500	24.755	628.78	138.94	8.684	1016.9	564.9
136	57.778	2.6047	0.17963	24.618	625.30	135.57	8.473	1016.4	564.7
137	58.333	2.6735	0.18438	24.478	621.74	132.29	8.268	1015.8	564.3
138	58.889	2.7438	0.18923	24.335	618.11	129.11	8.069	1015.2	564.0
139	59.444	2.8157	0.19419	24.188	614.38	126.01	7.876	1014.6	563.7
140	60.000	2.8892	0.19926	24.039	610.59	123.00	7.688	1014.0	563.3
141	60.556	2.9643	0.20443	24.886	606.70	120.07	7.504	1013.4	563.0
142	61.111	3.0411	0.20973	23.730	602.74	117.22	7.326	1012.9	562.7
143	61.667	3.1195	0.21514	23.570	598.68	114.45	7.153	1012.3	562.4
144	62.222	3.1997	0.22067	23.407	594.54	111.76	6.985	1011.7	562.1
145	62.778	3.2816	0.22632	23.240	590.30	109.14	6.821	1011.1	561.7
146	63.333	3.3653	0.23209	23.069	585.95	106.59	6.662	1010.5	561.4
147	63.889	3.4508	0.23799	22.895	581.53	104.11	6.507	1009.9	561.1
148	64.444	3.5381	0.24401	22.718	577.04	101.70	6.356	1009.3	560.7
149	65.000	3.6273	0.25016	22.536	572.41	99.35	6.209	1008.7	560.4
150	65.556	3.7184	0.25644	22.351	567.72	97.07	6.067	1008.2	560.1
151	66.111	3.8114	0.26286	22.161	562.89	94.84	5.928	1007.6	559.8
152	66.667	3.9065	0.26941	21.968	557.99	92.68	5.793	1007.0	559.4
153	67.222	4.0035	0.27610	21.770	552.96	90.57	5.661	1006.4	559.1
154	67.778	4.1025	0.28293	21.569	547.85	88.52	5.533	1005.8	558.8
155	68.333	4.2036	0.28990	21.363	542.62	86.52	5.408	1005.2	558.4
156	68.889	4.3068	0.29702	21.153	537.29	84.57	5.286	1004.6	558.1
157	69.444	4.4122	0.30429	20.938	531.83	82.68	5.168	1004.0	557.8
158	70.000	4.5197	0.31170	20.719	526.26	80.83	5.052	1003.4	557.4
159	70.556	4.6294	0.31927	20.496	520.60	79.04	4.940	1002.8	557.1
160	71.111	4.7414	0.32699	20.268	514.81	77.29	4.831	1002.2	556.8
161	71.667	4.8556	0.33487	20.035	508.89	75.58	4.724	1001.6	556.4
162	72.222	4.9722	0.34291	19.798	502.87	73.92	4.620	1001.0	556.1
163	72.778	5.0911	0.35111	19.556	496.72	72.30	4.519	1000.4	555.8
164	73.333	5.2124	0.35948	19.309	490.45	70.72	4.420	999.8	555.4
165	73.889	5.3361	0.36801	19.057	484.05	69.18	4.324	999.2	555.1
166	74.444	5.4623	0.37671	18.800	477.52	67.68	4.230	998.6	554.8
167	75.000	5.5911	0.38559	18.538	470.87	66.22	4.139	998.0	554.4
168	75.556	5.7223	0.39464	18.271	464.08	64.80	4.050	997.4	554.1
169	76.111	5.8562	0.40388	17.998	457.15	63.41	3.963	996.8	553.8

TEMPERATURE		PRESSURE		VACUUM		SPECIFIC VOLUME		LATENT HEAT	
°F	°C	PSIA	BAR	In Hg	mm Hg	Ft ³ /lb	m ³ /Kg	Btu/lb	Kcals/Kg
170	76.667	5.9926	0.41328	17.720	1.22207	62.06	3.879	996.2	553.4
171	77.222	6.1318	0.42288	17.437	1.20255	60.74	3.796	998.6	554.8
172	77.778	6.2736	0.43266	17.148	1.18262	59.45	3.716	998.0	554.4
173	78.333	6.4182	0.44263	16.854	1.16234	58.19	3.637	997.4	554.1
174	78.889	6.5656	0.45280	16.554	1.14166	56.97	3.561	996.8	553.8
175	79.444	6.7159	0.46317	16.248	1.12055	55.77	3.486	996.2	553.4
176	80.000	6.8690	0.47372	15.936	1.09903	54.61	3.413	995.6	553.1
177	80.556	7.0250	0.48448	15.618	1.07710	53.47	3.342	995.0	552.8
178	81.111	7.1840	0.49545	15.295	1.05483	52.36	3.273	994.4	552.4
179	81.667	7.3460	0.50662	14.965	1.03207	51.28	3.205	993.8	552.1
180	82.222	7.5110	0.51800	14.629	1.00890	50.225	3.139	993.2	551.8
181	82.778	7.679	0.52959	14.287	0.98531	49.194	3.075	992.6	551.4
182	83.333	7.850	0.54138	13.939	0.96131	48.189	3.012	992.0	551.1
183	83.889	8.025	0.55345	13.582	0.93669	47.207	2.950	991.4	550.8
184	84.444	8.203	0.56572	13.220	0.91172	46.249	2.891	990.8	550.4
185	85.000	8.384	0.57821	12.851	0.88628	45.313	2.832	990.2	550.1
186	85.556	8.568	0.59090	12.477	0.86048	44.400	2.775	989.6	549.8
187	86.111	8.756	0.60386	12.094	0.83407	43.508	2.719	989.0	549.4
188	86.667	8.947	0.61703	11.705	0.80724	42.638	2.665	988.4	549.1
189	87.222	9.141	0.63041	11.310	0.78000	41.787	2.612	987.8	548.8
190	87.778	9.340	0.64414	10.905	0.75207	40.957	2.560	987.1	548.4
191	88.333	9.541	0.65800	10.496	0.72386	40.146	2.509	986.5	548.1
192	88.889	9.747	0.67221	10.076	0.69490	39.354	2.460	985.9	547.7
193	89.444	9.956	0.68662	9.651	0.66559	38.580	2.411	985.3	547.4
194	90.000	0.168	0.70124	9.219	0.63579	37.824	2.364	984.7	547.1
195	90.556	10.385	0.71621	8.777	0.60531	37.086	2.318	984.1	546.7
196	91.111	10.605	0.73138	8.329	0.57441	36.364	2.273	983.5	546.4
197	91.667	10.830	0.74690	7.871	0.54283	35.659	2.229	982.8	546.0
198	92.222	11.058	0.76262	7.407	0.51083	34.970	2.186	982.2	545.7
199	92.778	11.290	0.77862	6.935	0.47828	34.297	2.144	981.6	545.3
200	93.333	11.526	0.79490	6.454	0.44510	33.639	2.102	981.0	545.0
201	93.889	11.766	0.81145	5.966	0.41145	32.996	2.062	980.4	544.7
202	94.444	12.011	0.82834	5.467	0.37703	32.367	2.023	979.7	544.3
203	95.000	12.259	0.84545	4.962	0.34221	31.752	1.985	979.1	543.9
204	95.556	12.512	0.86290	4.447	0.30669	31.151	1.947	978.5	543.6

TEMPERATURE		PRESSURE		VACUUM		SPECIFIC VOLUME		LATENT HEAT	
°F	°C	PSIA	BAR	In Hg	mm Hg	Ft ³ /lb	m ³ /Kg	Btu/lb	Kcals/Kg
205	96.111	12.782	0.88128	3.9296	99.8097	30.564	1.910	974.7	541.5
206	96.667	13.043	0.89928	3.3723	84.6551	29.989	1.874	974.1	541.2
207	97.222	13.310	0.91968	2.8301	71.8838	29.428	1.839	973.5	540.8
208	97.778	13.581	0.93637	2.2783	57.8690	28.878	1.805	972.8	540.4
209	98.333	13.856	0.95533	1.7184	43.6474	28.341	1.771	972.2	540.1
210	98.889	14.136	0.97464	1.1483	29.1672	27.816	1.739	971.6	539.8
211	99.444	14.421	0.99439	0.5681	14.4285	27.302	1.706	970.9	539.4
212	100.000	14.700	1.01351			26.799	1.675	970.3	539.1
213	100.556	15.003	1.03442			26.307	1.644	969.7	538.7
214	101.111	15.302	1.05504			25.826	1.614	969.0	538.3
215	101.667	15.606	1.07599			25.355	1.585	968.4	538.0
216	102.222	15.915	1.09730			24.894	1.556	967.8	537.7
220	104.444	17.201	1.18597			23.148	1.447	965.2	536.2
224	106.667	18.591	1.28043			21.545	1.347	962.6	534.8
228	108.889	20.031	1.38109			20.037	1.252	960.0	533.3
232	111.111	21.583	1.48810			18.718	1.170	957.4	531.9
236	113.333	23.233	1.60186			17.471	1.092	954.8	530.4
240	115.556	24.985	1.72266			16.321	1.020	952.1	528.9
244	117.778	26.844	1.85083			15.260	0.954	949.5	527.5
248	120.000	28.814	1.98666			14.281	0.893	946.8	526.0
252	122.222	30.901	2.13054			13.375	0.836	944.1	524.5
256	124.444	33.110	2.28283			12.538	0.784	941.4	523.0
260	126.667	35.445	2.44385			11.762	0.735	938.6	521.4
264	128.889	37.913	2.61009			11.042	0.690	935.9	519.9
268	131.111	40.518	2.79362			10.375	0.648	933.1	518.4
272	133.333	43.267	2.98315			9.755	0.610	930.3	516.8
276	135.556	46.165	3.18296			9.180	0.574	927.5	515.3
280	137.778	49.218	3.39346			8.6439	0.540	924.6	513.7
284	140.000	52.431	3.61499			8.1453	0.509	921.7	512.1
288	142.222	55.812	3.84810			7.6807	0.480	918.8	510.4
292	144.444	59.366	4.09314			7.2475	0.453	915.9	508.8
296	146.667	63.100	4.35059			6.8433	0.428	913.0	507.2

TEMPERATURE		PRESSURE		VACUUM		SPECIFIC VOLUME		LATENT HEAT	
°F	°C	PSIA	BAR	In Hg	mm Hg	ft ³ /lb	m ³ /Kg	Btu/lb	Kcals/Kg
300	148.889	67.005	4.62103			6.4658	0.404	910.0	505.6
304	151.111	71.119	4.90476			6.1130	0.382	907.0	503.9
308	153.333	75.433	5.20228			5.7830	0.361	904.0	502.2
312	155.556	79.953	5.51400			5.4742	0.342	901.0	500.6
316	157.778	84.668	5.83917			5.1849	0.324	897.9	498.8
320	160.000	89.643	6.18228			4.9138	0.307	894.8	497.1
324	162.222	94.826	6.53972			4.6595	0.291	891.6	495.3
328	164.444	100.245	6.91345			4.4208	0.276	888.5	493.6
332	166.667	105.907	7.30393			4.1966	0.262	885.3	491.8
336	168.889	111.820	7.71172			3.9859	0.249	882.1	490.1
340	171.111	117.992	8.13738			3.7878	0.237	878.8	488.2
344	173.333	124.430	8.58138			3.6013	0.225	875.5	486.4
348	175.556	131.142	9.04428			3.4258	0.214	872.2	484.6
352	177.778	138.138	9.52676			3.2603	0.204	868.9	482.7
356	180.000	145.424	10.02924			3.1044	0.194	865.5	480.8
360	182.222	153.010	10.55241			2.9573	0.185	862.1	478.9
364	184.444	160.903	11.09676			2.8184	0.176	858.6	477.0
368	186.667	169.113	11.66297			2.6873	0.168	855.1	475.1
372	188.889	177.648	12.25159			2.5633	0.160	851.6	473.1
376	191.111	186.517	12.86324			2.4462	0.153	848.1	471.2
380	193.333	195.729	13.49855			2.3353	0.146	844.5	469.2
384	195.556	205.294	14.15821			2.2304	0.139	840.8	467.1
388	197.778	215.220	14.84276			2.1311	0.133	837.2	465.1
392	200.000	225.516	15.55283			2.0369	0.127	833.4	463.0
396	202.222	236.193	16.28917			1.9477	0.122	829.7	460.9

Notes:

Notes:



Your local contact:



APV, An SPX Brand

105 CrossPoint Parkway

Getzville, NY 14068

Phone: (716) 692-3000 (800) 207-2708 Fax: (716) 692-1715

E-mail: answers.us@apv.com

For more information about our worldwide locations, approvals, certifications, and local representatives, please visit www.apv.com.

SPX reserves the right to incorporate our latest design and material changes without notice or obligation.

Design features, materials of construction and dimensional data, as described in this bulletin, are provided for your information only and should not be relied upon unless confirmed in writing.