



# APV Homogeniser

## Rannie 132T /Gaulin 132T

### Introduction

The Rannie 132T / Gaulin 132T homogeniser, a positive displacement triplex, reciprocating plunger pump, is fitted with an application-specific homogenising valve assembly: single-stage with hydraulic actuation. As a high-pressure pump, this unit can be fitted with a relief valve.



*Rannie three-piece valve housing*

The Rannie 132T / Gaulin 132T homogeniser incorporates a durable slow-speed power end that reduces vibration and noise. Easy access to the hydraulic actuation system, lubrication oil and other auxiliary systems simplifies maintenance saving time and money. Liquid end options include a three-piece valve housing (Rannie) or a mono-block design (Gaulin).

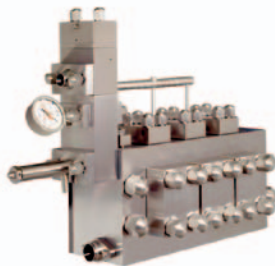

*Gaulin mono-block design*

Design features of both the Rannie and Gaulin simplify routine maintenance. Materials for plungers, packings, pump valves, valve seats and seals are custom-selected for your application. SPX engineers will work with you to optimise the configuration for your specific application.

### Standard Options

- Two-stage hydraulic valve actuation (HVA)
- Single-stage automatic hydraulic system (AHS)
- Two-stage automatic hydraulic system (AHS)
- Pulsation dampener(s) on inlet and outlet
- Aseptic cylinder design
- High-pressure outlet
- Inlet pressure gauge
- Plunger lubrication control package
- Micro-Gap homogenising valve
- Tungsten carbide homogenising valve
- Square plunger seals and ceramic plungers (Rannie valve housing only)
- External cooling fan/main motor
- Motor starter
- Control cabinet, stainless steel
- Thermostat/oil temperature

### Special Options

- Acid-proof cylinder (Gaulin valve housing only)
- Ceramic plungers with U- or V-rings
- Explosion-proof design
- Electropolished wettables
- High-temperature design
- Flow switch - power end cooling

## Rannie/Three-Piece Valve Housing Poppet and Ball Type Valves

Type	US max. cap./max. press.		Metric max.cap./max. press.	
	GPH	PSI	LPH	BAR
85.140	5810	2900	22000	200
75.140	4490	3625	17000	250
70.140	3910	4300	15000	300
60.140	2905	5800	11000	400
50.140	1980	8700	7500	600
42.140	1350	11600	5100	800
38.140	1060	14500	4000	1000

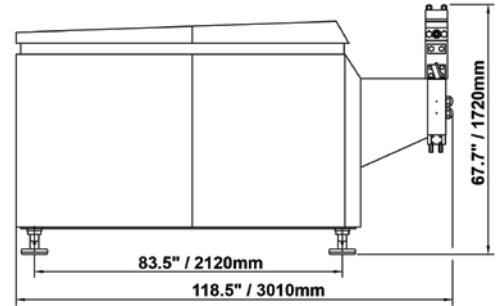
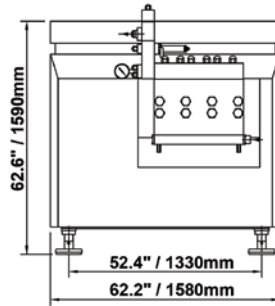

## Gaulin/Mono-Block Design

Type	US max. cap./max. press.		Metric max.cap./max. press.	
	GPH	PSI	LPH	BAR
Poppet type valves				
3.0	5150	3000	19500	210
4.3	3435	4300	15000	300
5.8	2905	5800	11000	400
Ball type valves				
3.0	5020	3000	19000	210
4.3	3300	4300	14500	300
5.8	2775	5800	10500	400
8.7	1950	8700	7400	600

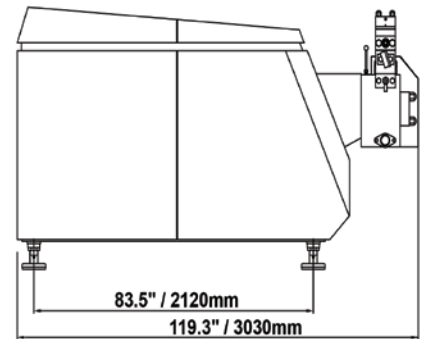
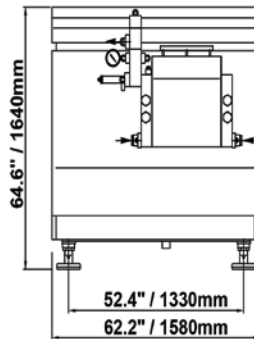

## Dimensions (single stage)

Dimensions packed in a crate LxWxH (in.)	Dimensions packed in a crate LxWxH (cm)	Cubic measure m <sup>3</sup>	Gross weight in a crate, incl. motor
124.4 x 82.2 x 77.2	311 x 178 x 193	10.7	11,244 lb. / 5,100 kg

SPX Flow Technology  
 Phone: (888) 278-4321  
 Email: [answers.us@apv.com](mailto:answers.us@apv.com)  
[www.apv.com](http://www.apv.com)  
[www.spxft.com](http://www.spxft.com)

For more information about our worldwide locations, approvals, certifications, and local representatives, please visit [www.apv.com](http://www.apv.com).

SPX Corporation reserves the right to incorporate our latest design and material changes without notice or obligation. Design features, materials of construction and dimensional data, as described in this bulletin, are provided for your information only and should not be relied upon unless confirmed in writing.