

Butter and spread technology



Butter and spreads or blends

Proven systems and dedicated specialists

APV has specialist experience in the supply of equipment for the manufacture of butter, low fat butter and dairy blends. For many years APV has designed and engineered plants world-wide to produce a continuing variety of products in response to market demands. APV has successfully developed a new range of processes capable of producing high added-value low fat spreads and dairy blends.

Proven systems

Today, our scope of supply for butter making includes: cream treatment, complete butter plants, butter buffer and butter pumping systems, butter packaging, blending of different types of butter, butter reworking and butter melting.

Further we offer our customers up-grade of existing plants as well as an excellent after market service.

A dedicated team of specialists

- World-class innovation, engineering, sales and service competence
- More than 500 references of butter systems
- Strong know-how platform
- Innovation centre and pilot plant service
- Excellent customer service

Continuous butter making machine - HCT

Six different sizes, each with a wide capacity range



Specifications

Field of application	Butter
Description	Semi-automatic in production, fully automated CIP
Capacity	500 - 12,000 kg/h (1,100 - 26,450 lbs/h)

Advantages

- Built-in cream pre-heater
- Built-in butter milk cooling
- Low air content in final product
- Advanced dosing system for water, salt and culture
- Internal CIP system
- Factory tested before shipping
- Each machine size has a wide capacity range

Butter buffer tank - HRS+

Acts as a buffer tank, for example between a butter making machine and one or more packaging machines



Specifications

Field of application	Butter, butter spreads, dairy blends
Description	Closed tank with two transport augers. Outlet connections for one or more butter pumps
Capacity	1,500 - 2,500 - 4,000 - 5,500 - 7,000 kg (3,300 - 5,500 - 8,800 - 12,100 - 15,400 lbs)

Advantages

- Inclined bottom for reduced water consumption during CIP
- Reduced CIP time
- Replaceable plain bearing on augers
- No auger joints in product area
- Re-inforced design
- 1 - 4 butter pumps

Butter silo - HCS

Acts as a buffer tank, for example between a butter making machine and one or more packaging machines



Specifications

Field of application	Butter, butter spreads, dairy blends
Description	Closed tank without transport augers. Outlet connections for one or more butter pumps
Capacity	900 and 1,800 kg (1,980 and 3,960 lbs)

Advantages

- No augers
- No additional working of the product
- 1 - 5 butter pumps

Dairy blend plant

Plant for manufacture of spreadable butter products by mixing butter with a vegetable oil etc.



Specifications

Field of application	Butter spreads, dairy blends
Description	Fully automatic system for mixing butter with a vegetable oil to make a product that is spreadable straight from the refrigerator
Capacity	500 - 2,500 kg/h or 2,000 - 7,000 kg/h (1,100 - 5,500 lbs/h or 4,400 - 15,430 lbs/h)

Advantages

- No vegetable oil residues in the buttermilk
- Great flexibility for oil injection of unsaturated and saturated oils
- Simultaneous injection of several oil types
- Flexible end-product range
- Total fat content in final product typically 60 - 80%
- Vegetable oil content - typically 20 - 30%
- Stand-alone system, factory tested before shipping
- Advanced control system for end-product versatility and uniformity
- Each machine has a wide capacity range
- APV patented process

Low fat butter plant

Plant for manufacture of a spreadable low-fat butter product by mixing butter with a water phase



Specifications

Field of application	Butter spreads, dairy blends
Description	Fully automatic system for mixing butter with a water phase in order to make a low-fat product that is spreadable straight from the refrigerator
Capacity	500 - 2,500 kg/h (1,100 - 5,500 lbs/h)

Advantages

- Great flexibility for injection of a water phase
- Flexible end-product range
- Total fat content in final product typically 25 - 60%
- Water phase typically 50%
- Stand-alone system, factory tested before shipping
- Advanced control system for end-product versatility and uniformity
- Wide capacity range
- APV patented process

Butter mixing plant

Mixing of tempered butter or margarine with different types of powder and liquid ingredients



Specifications

Field of application	Butter, dairy blends, margarine
Description	Fully automatic, continuous system for mixing butter with powder ingredients to obtain a uniform end-product. Liquid ingredients can also be added to the formulation
Capacity	500 - 5,000 kg/h (1,100 - 11,000 lbs/h) depending on application

Advantages

- A continuous, closed system for a uniform end-product
- Low mixing temperature, minimising the risk of bacteriological issues
- CIP and sanitising without dismantling
- Stand-alone system, factory tested before shipping
- Advanced control system for end-product versatility and uniformity
- Wide capacity range

Butter reworking plant

Reworking of tempered bulk butter



Specifications

Field of application	Butter
Description	Fully automatic, continuous system for reworking bulk butter
Capacity	500 - 5,000 kg/h (1,100 - 11,000 lbs/h), depending on application
Temperature	Minimum product temperature 3°C (37,4°F)

Advantages

- CIP and sanitising without dismantling
- Continuous, closed system minimising the risk of bacteriological issues
- Available with a vacuum chamber for vacuum treatment of the product
- Precise dosing of water, salt, culture etc. to ensure a uniform end-product
- Stand-alone system, factory tested before shipping
- Advanced control system for end-product versatility and uniformity
- Wide capacity range

Butter melting plant

Melting or tempering of bulk butter

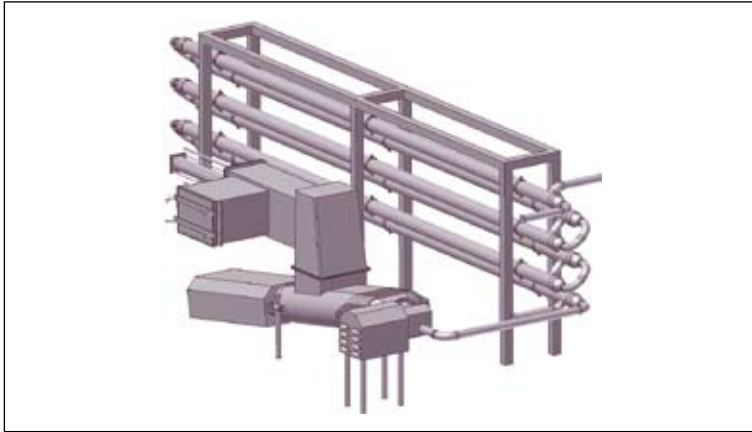

Specifications

Field of application	Butter, margarine
Description	Fully automatic, continuous system for reworking and tempering/melting of bulk butter
Capacity	500 - 6,000 kg/h (1,100 - 13,230 lbs/h), depending on application
Temperature	From 3°C (37,4°F) and up to a specified end temperature, depending on application

Advantages

- CIP and sanitising without dismantling
- Continuous, closed system minimising the risk of bacteriological issues
- Stand-alone system, factory tested before shipping
- Advanced control system for end-product versatility and uniformity
- Wide capacity and end temperature range
- Less floor space required compared to traditional melting tanks

DarMix+

In-line mixer for mixing of butter and butter blends

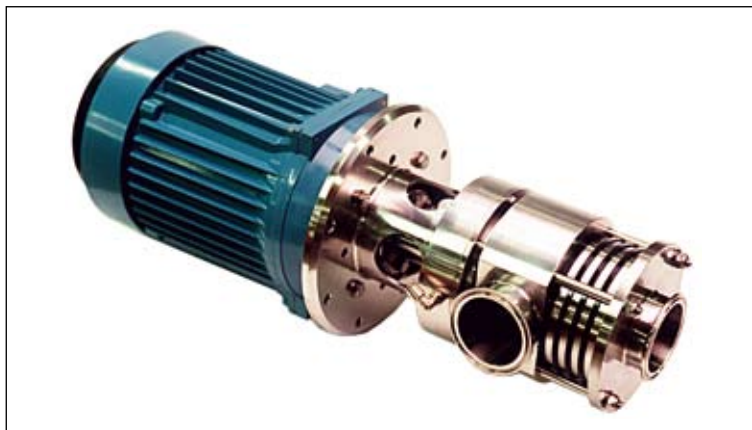

Specifications

Field of application	Butter, butter spreads, dairy blend
Description	Compact and highly efficient in-line mixer. Mixing intensity (rpm) controlled by a frequency converter
Temperature	8 - 18°C (46,4 - 64,4°F)

Advantages

- Applicable for high- and low-viscosity products
- Ensures a homogeneous product
- No product contacting bearings
- Compact design
- Cleaning simultaneously with the pipeline

Butter packaging line - FMG

Fully automatic butter bulk packer for 20, 25 and 31 kg (44, 55 and 68,3 lbs) cartons



Specifications	
Field of application	Butter
Description	Fully automatic packaging machine including carton former, tare scale, filling heads, precision dosing, internal check weighing, and liner closing. Control system includes data collection of each carton filled. Post-production generation of production and CIP reports
Capacity	FMG-1: Max 180 cartons/h (3,600 - 5,580 kg/h) (7,930 - 12,300 lbs/h) FMG: Max 290 cartons/h (5,800 - 8,990 kg/h) (12,780 - 19,820 lbs/h) FMG+: Max 440 cartons/h (8,800 - 11,000 kg/h) (19,400 - 24,250 lbs/h)

Advantages

- Stainless steel throughout
- Single, compact unit
- Accurate filling for less give-away of butter
- Available with a troubleshooting system to reduce the down time
- Advanced control system with data collection
- Factory tested before shipping
- Each machine size has a wide capacity range
- FMG+ is capable of packing two different carton sizes at the same time

Butter packaging line - CAF

Semi-automatic butter bulk packer for 5 to 25 kg (11 to 55 lbs) cartons



Specifications	
Field of application	Butter
Description	Semi-automatic packaging machine including transport system, filling heads, precision dosing and internal check weighing. The control system includes data collection of each carton filled. Production and CIP reports can be created after production
Capacity	CAF-1: Max 145 cartons/h (725 - 3,625 kg/h) (1,600 - 7,990 lbs/h) CAF-2: Max 270 cartons/h (1,350 - 6,750 kg/h) (2,970 - 14,880 lbs/h)

Advantages

- Stainless steel throughout
- One compact unit
- CAF-2 can pack two different carton sizes at the same time
- Accurate filling - less give away of butter
- Advanced control system with data collection
- Factory tested before shipping
- Each machine has a wide capacity range

Butter pilot plant facility

Upscalable application for development and testing at APV's Innovation Centre



Specifications

Field of application	Butter, butter spreads, dairy blends, margarine and other butter based products
Description	Complete pilot plant with APV applications and process engineering support
Capacity	300 - 1,500 kg/h (660 - 3,300 U.S. g/h)

Advantages

- Production-scalable process, development, testing and optimisation
- Highly flexible pilot plant enabling several product trials per day

APV's Innovation Centre

R&D and technology service



The APV Innovation Centre leverages the extensive industry experience and expertise of a permanent staff of food technologists, process engineers and production engineers together with knowledge gained over many years throughout the worldwide APV Group to contribute actively to all types of development, testing and application of APV equipment, systems and processing lines. All facilities and services are designed to provide added value by minimising waste and energy requirements, or by converting commodity ingredients into new, competitive products.

Important keywords for the Centre are innovation, optimum plant dimensioning, high-quality products, and up-to-date knowledge of market requirements. The trials are custom-tailored and can be performed in the Innovation Centre or on customer site. All work on behalf of individual customers is subject to the strictest confidentiality and the highest standards of customer service.

Continuous butter making machine - HCT

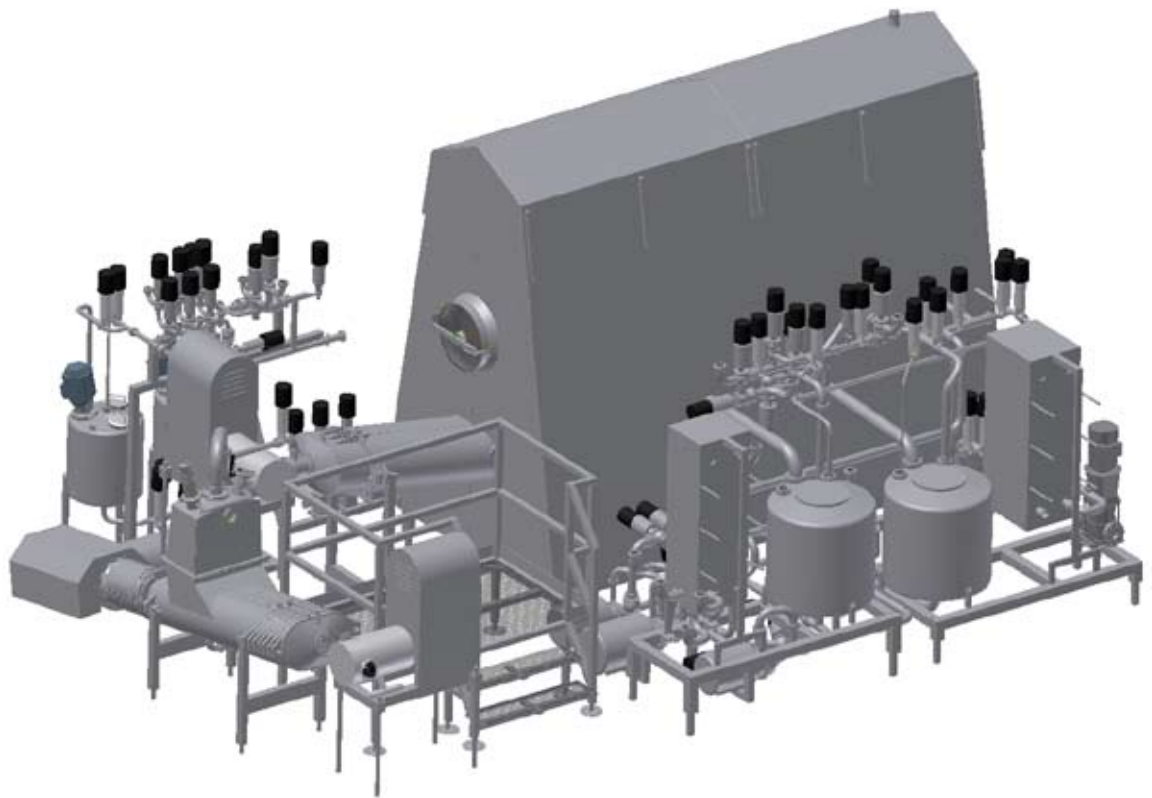

Butter packing line - FMG

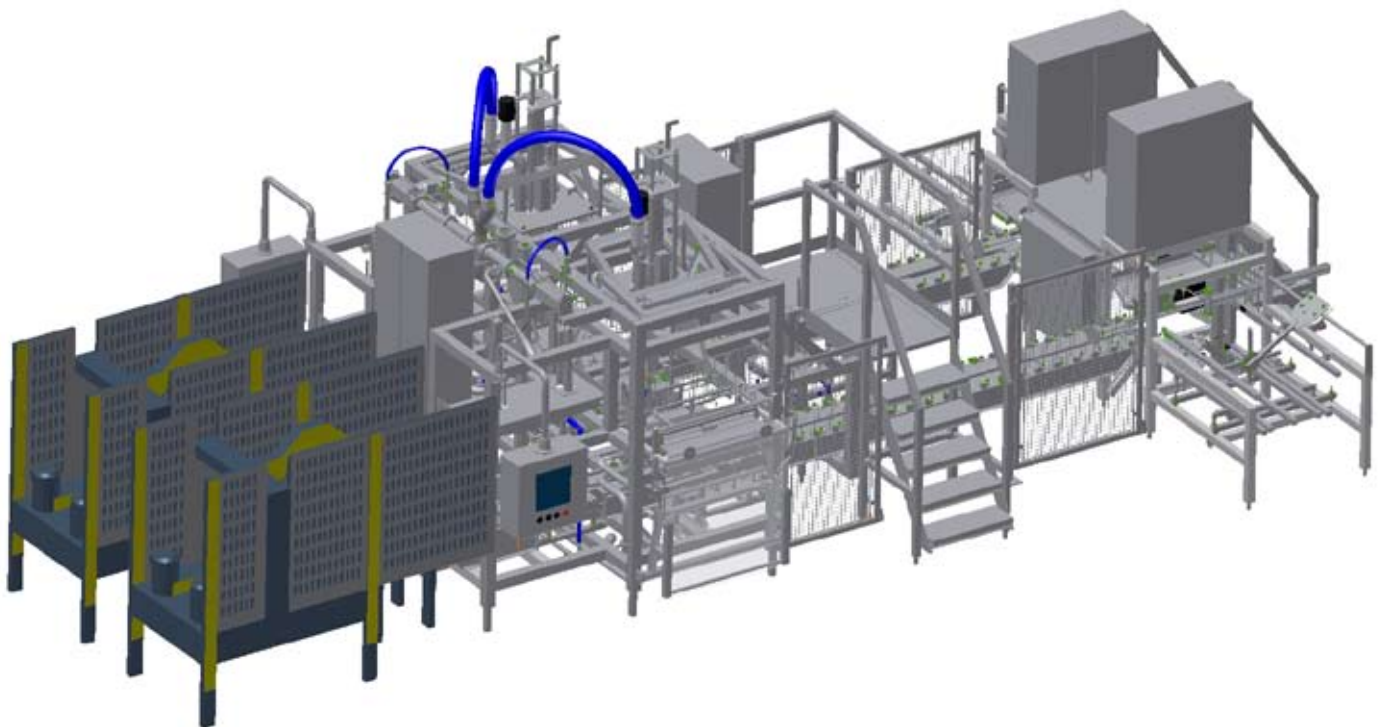

Butter and dairy spread processing

Complete processing line from cream or reworking to butter bulk packing

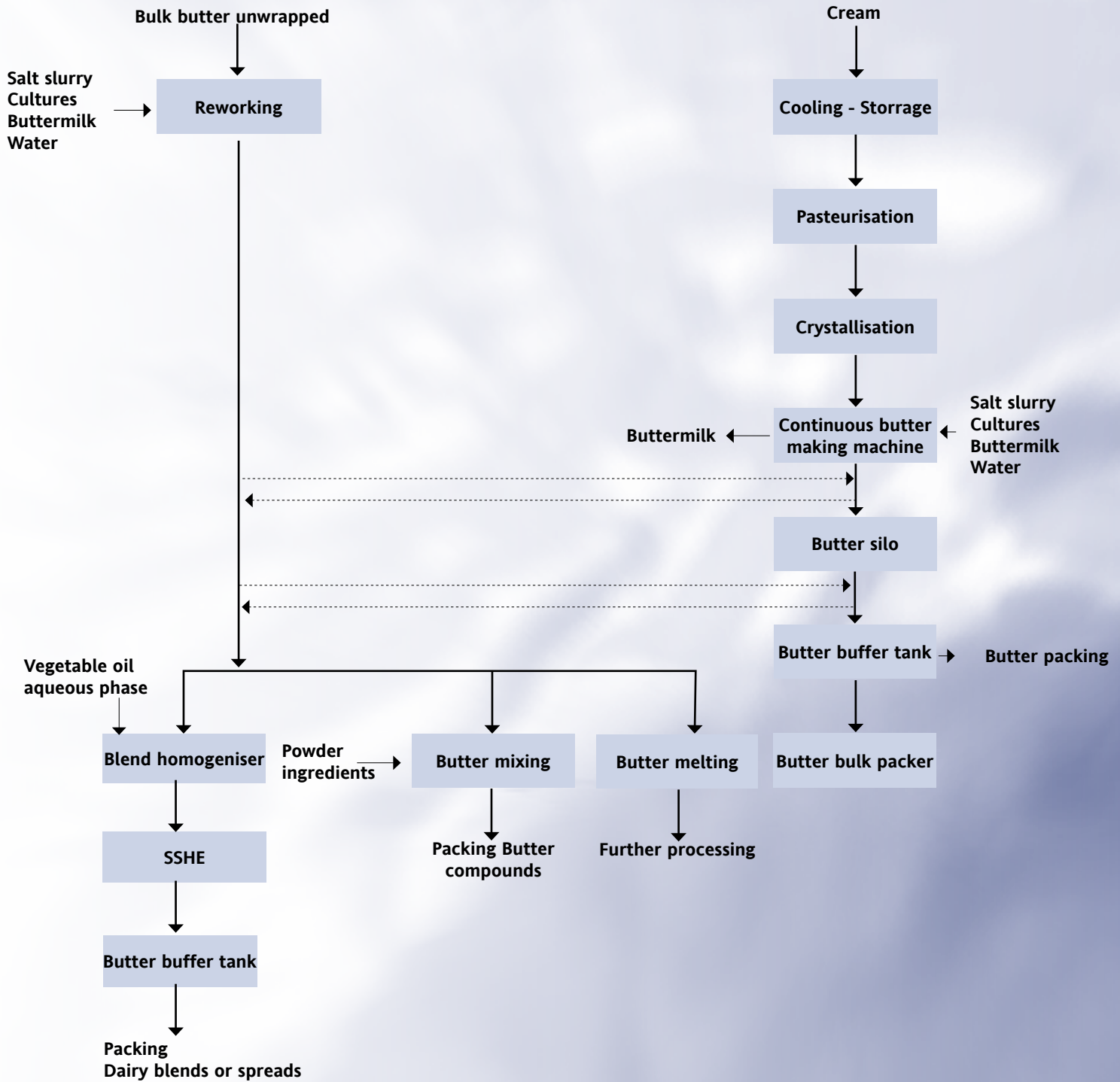

Production of low-fat butter without additives

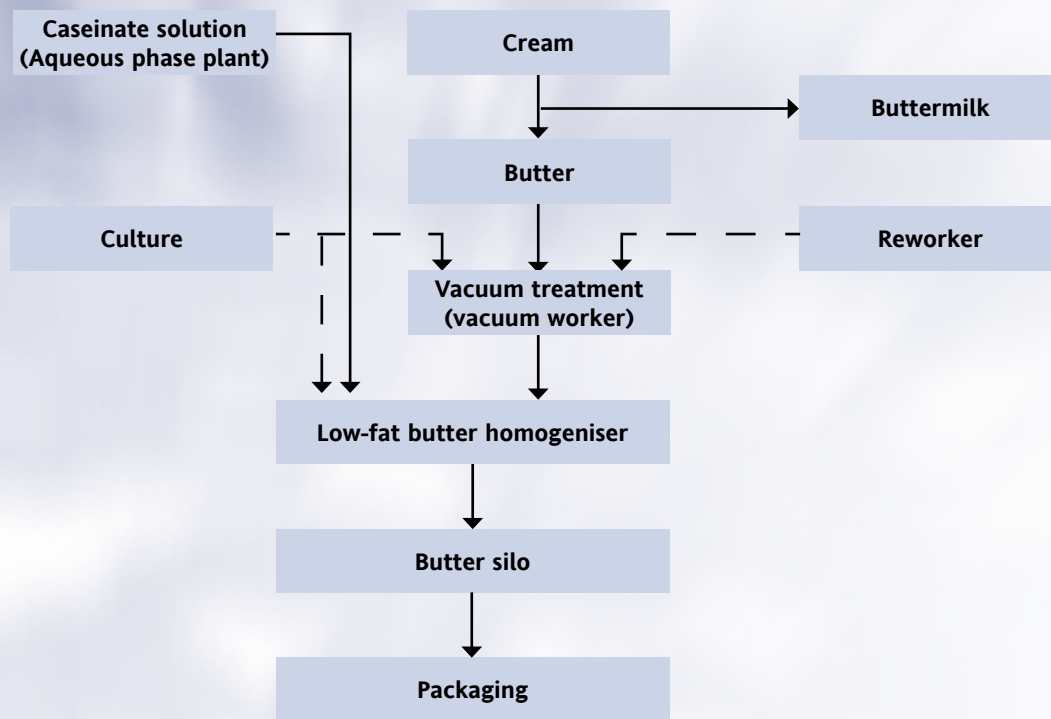

Production of low-fat butter with additives

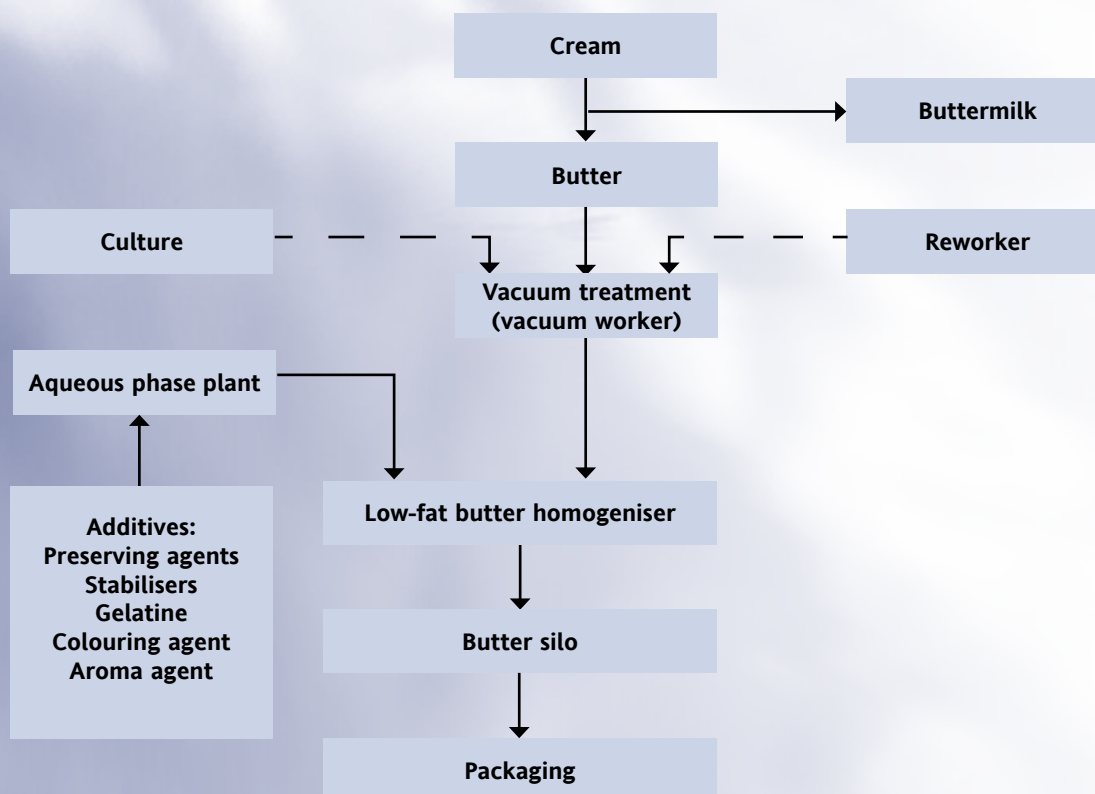



Your local contact:



APV, An SPX Brand
Pasteursvej 1
8600 Silkeborg, Denmark
Phone: +45 70 278 278 Fax: +45 70 278 330

For more information about our worldwide locations, approvals, certifications, and local representatives, please visit www.apv.com.

SPX Corporation reserves the right to incorporate our latest design and material changes without notice or obligation. Design features, materials of construction and dimensional data, as described in this bulletin, are provided for your information only and should not be relied upon unless confirmed in writing.