

APV Lab Series Homogenizers

1000/2000 Series



Compact, versatile design specifically developed for R&D laboratories within the dairy, food, chemical, pharmaceutical, cosmetic and biotech industries

Now you can achieve fully reproducible results for emulsions, dispersions, or cell disruption that can be applied to full-scale production with complete confidence.

Plus, you can test sample sizes as small as 100 ml at adjustable pressures up to 29,000 psi (2000 bar) – the highest pressure of any lab unit available – for unmatched research flexibility and cost efficiencies.

APV Lab Series Homogenizers provide the desired mean particle size and narrow, uniform distribution you need to help you improve existing products and develop new ones.

- Unique, homogenizing valve designed to deliver superior performance in producing emulsions and dispersions, while optimizing the cell disruption process
- Available two-stage homogenizing valve can be specified in either tungsten carbide or ceramics
- Features an easy-to-read digital pressure display and electronic pressure safety system
- Small footprint – suitable for benchtop location

- Field-replaceable and reversible tungsten carbide pump valve seats
- Smooth, quiet and reliable operation

APV Lab Series Homogenizers

Two units are available to meet your laboratory requirements; operating pressures of 14,500 psi (1000 bar) and 29,000 psi (2000 bar) with nominal capacities of 6 g/h (22 l/h) and 3 g/h (11 l/h) respectively. The units are ideal for a wide variety of emulsions and dispersions.



Typical Applications



Food/Beverage:

- Beverage Emulsions
- Fat Substitutes
- Milk
- Sauces



Health care/Cosmetics:

- Hair Products
- Liposome Emulsions
- Nail Polish
- Skin Creams



Pharmaceutical /Biotech:

- Cell Disruption
- Intravenous Emulsions
- Nutritional Supplements
- Ointments



Chemical:

- Inks
- Pigment Dispersions
- Silicone Emulsions
- Specialty Paints and Coatings

A closer look at the homogenization process

The Theory Of Homogenization

The unhomogenized product (E) enters the valve seat (B) at high pressure and low velocity. As the product flows through the adjustable, close clearance area between the valve (A) and seat (B), there is a rapid increase in velocity with a corresponding decrease in pressure. This intense energy transition, occurring in microseconds, produces turbulent three-dimensional mixing layers that disrupt the particles at the discharge from the gap (D). The homogenized product (F) impinges on the impact ring (C) and exits at a pressure sufficient for movement to the next processing stage.

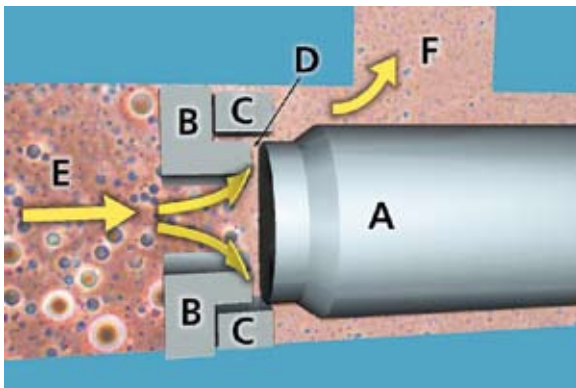

Homogenizing Techniques

Single-stage or two-stage homogenization:

For processing of emulsions, a single-stage valve assembly may be used; however, the use of a two-stage assembly, where approximately 10% of the total pressure is applied to the second stage, will improve the droplet size reduction of most emulsions.

For processing dispersions, a single-stage valve assembly is usually preferred.

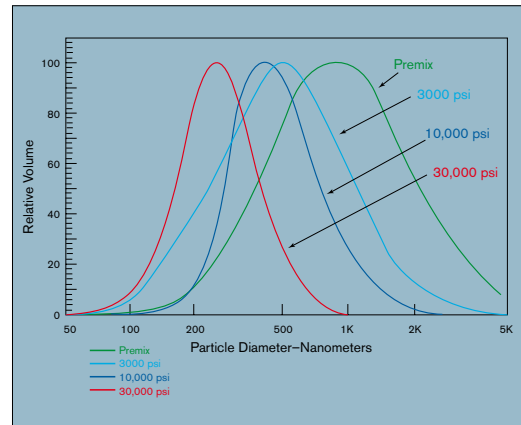

Above: The reduction in average particle size resulting from homogenization at various pressures.

Multiple-pass homogenization:

If an extremely narrow particle size distribution is required, it may be necessary to homogenize the product more than once. This can be done by two or more homogenizers in series or by repeating a pass through the same homogenizer. Using discrete passes through the homogenizer is the preferred procedure for multiple-passing a product. Some examples of multiple-pass products are intravenous emulsions, blood substitutes and parental emulsions.

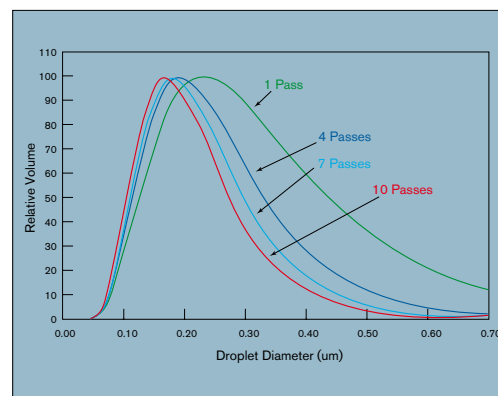

Above: The effect of up to 10 discrete passes at 14,500 psi (1000 bar) on an oil-in-water intravenous emulsion. Each pass results in a shift of the particle size distribution towards smaller droplet sizes.

Technical Specifications

Standard Features / Equipment	Model 1000	Model 2000
Capacity	6 g/h (22 l/h)	3 g/h (11 l/h)
Minimum Test Sample	150 ml	100 ml
Maximum Operating Pressure	14,500 psi (1,000 bar)	29,000 psi (2,000 bar)
Plunger Diameter/Material	14mm / Ceramic	10mm / Ceramic
Plunger Packing *	PVDF/EPDM	PVDF/EPDM
O-Rings/Backup Ring *	EPDM/POM	EPDM/POM
Pump Valve Seat Material *	Tungsten Carbide	Tungsten Carbide
Pump Valve	Cobalt Based Alloy	Cobalt Based Alloy
Homogenizing Valve/Seat *	Ceramic	Ceramic
Digital Pressure Display	Yes	Yes
Over Current Pressure Safety System	Yes	Yes
Motor	TEFC. 3kW, three-phase/50-60 Hz / 200, 230, 380, 400, 460, 575 Volts	TEFC. 3kW, three-phase/50-60 Hz / 200, 230, 380, 400, 460, 575 Volts

PVDF - Polyvinylidene Fluoride, EPDM - Ethylene Propylene Diene Monomer, POM - Acetal Polymer

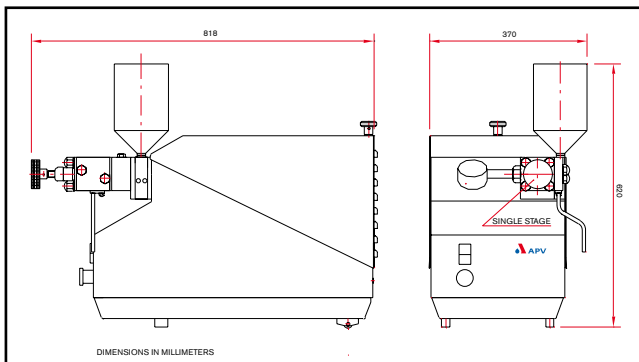

Net weight 231 lbs. (105 kgs) · Gross weight 286 lbs. (130 kgs) · Volume 30,511 in.³ (0.5 m³)

Optional Equipment

- Air operated pressure feeder assembly
- Explosion proof design
- Two-stage homogenizing valve assembly
- Aseptic cylinder design
- Digital gauge and gauge adapter for second stage pressure readout

* *Elastomers and wettables available in alternative material*

SPX[®]
WHERE IDEAS MEET INDUSTRY

Your local contact:



APV, An SPX Brand
Phone: (888) 278-4321
Email: answers.us@apv.com

For more information about our worldwide locations, approvals, certifications, and local representatives, please visit www.apv.com.

SPX Corporation reserves the right to incorporate our latest design and material changes without notice or obligation.

Design features, materials of construction and dimensional data, as described in this bulletin, are provided for your information only and should not be relied upon unless confirmed in writing.