



White Paper

CIP and Sanitation of Process Plant



Table of Contents

| | |
|--|----|
| Executive Summary- - - - - | 4 |
| Introduction to SPX Flow Technology - - - - - | 4 |
| Introduction to CIP and sanitation - - - - - | 5 |
| Design for cleanability - - - - - | 6 |
| Materials of construction - - - - - | 6 |
| Surface finish - - - - - | 6 |
| Welds - - - - - | 6 |
| Dismountable pipe couplings- - - - - | 6 |
| Examples of poor hygienic design - - - - - | 7 |
| Fouling of process plant - - - - - | 7 |
| Assessment of cleaning efficiency - - - - - | 8 |
| CIP design criteria- - - - - | 9 |
| Choice of chemicals - - - - - | 9 |
| Circulation time - - - - - | 9 |
| Operating temperatures - - - - - | 9 |
| Flow velocity - - - - - | 9 |
| Selection of spray devices- - - - - | 9 |
| Selection of CIP pumps - - - - - | 10 |
| Purging of product from the process plant- - - - - | 10 |
| Re-use of cleaning solutions - - - - - | 11 |
| CIP cycles- - - - - | 11 |
| Design of CIP bulk units - - - - - | 12 |
| CIP of the CIP unit - - - - - | 13 |
| Standard APV CIP units - - - - - | 13 |
| Automation of CIP systems - - - - - | 16 |
| CIP analysis & optimisation - - - - - | 16 |
| Pipework & valve designs - - - - - | 17 |
| Innovative new CIP technology- - - - - | 18 |
| Glossary - - - - - | 22 |

Executive Summary

CIP, or Cleaning-in-Place, is a critical process hygiene aspect that helps to ensure the health and safety of the consumer.

This white paper discusses the concept of cleanability by looking at the materials, finish, welding and design features that play a major role in effective CIP systems. It goes on to examine the various methods of CIP cleaning. Finally it takes a brief look at new CIP technology using electro-chemically activated water in cleaning and sanitising solutions.

Together with its other processing solutions, SPX offers a comprehensive platform of skid-mounted CIP solutions (FX Systems). All SPX CIP solutions can be automated as an additional safety measure and in order to document the CIP operation.

The SPX Innovation Centre in Denmark offers Pilot testing and application solution guidance services to help customers maximize the performance of their plant. Pilot testing can also be conducted on customers' own premises based on rental equipment and, if required, with support from SPX experts.

Introduction to SPX Flow Technology

Vision and commitment

SPX's Flow Technology segment designs, manufactures and markets process engineering and automation solutions to the dairy, food, beverage, marine, pharmaceutical and personal care industries through its global operations.

We are committed to helping our customers all over the world to improve the performance and profitability of their manufacturing plant and processes. We achieve this by offering a wide range of products and solutions from engineered components to design of complete process plants supported by world-leading applications and development expertise.

We continue to help our customers optimise the performance and profitability of their plant throughout its service life with support services tailored to their individual needs through a coordinated customer service and spare parts network.

Customer focus

Founded in 1910, APV, an SPX Brand, has pioneered groundbreaking technologies over more than a century, setting the standards of the modern processing industry.

Continuous research and development based on customer needs and an ability to visualise future process requirements drives continued mutual growth.



Introduction to CIP and sanitation

Cleaning and sanitisation of process plant is one of the most critical aspects of food processing to ensure the health and safety of the consumer. Proper cleaning is essential for the production of high quality food products especially those with extended shelf life.

Cleaning-in-Place (CIP) is now a very common practice in many dairy, processed food, beverage and brewery plant replacing manual strip down, cleaning and rebuilding of process systems. The primary commercial advantage is a substantial reduction in the time that the plant is out of production and the ability to utilise more aggressive cleaning chemicals in a contained environment which cannot be safely handled with manual cleaning.

The definition of CIP is given in the 1990 edition of the Society of Dairy Technology manual "CIP: Cleaning in Place" as:

"The cleaning of complete items of plant or pipeline circuits without dismantling or opening of the equipment, and with little or no manual involvement on the part of the operator. The process involves the jetting or spraying of surfaces or circulation of cleaning solutions through the plant under conditions of increased turbulence and flow velocity."

CIP is not simply the provision of a CIP bulk unit but the integrated process and hygienic design of the complete process. A CIP system will consist of vessels for preparation and storage of cleaning chemicals, pumps and valves for circulation of the CIP chemicals throughout the plant, instrumentation to monitor the cleaning process and vessels to recover the chemicals.

Although CIP systems are usually fully automated, the process is often a combination of manual actions and automatic sequencing. This applies especially to operations within a process plant where different types and/or concentrations of cleaning chemicals are utilised. For example, a membrane filtration system with polymeric membranes would be damaged if exposed to sodium hydroxide and nitric acid solutions routinely used in most centralised CIP operations.

In the most simple application, CIP solutions can be used once (single-use CIP) and then discarded to drain, but this is very expensive in cleaning chemicals, water use and effluent costs. Such operation is not environmentally friendly and can only be justified if it is essential to apply a single use system to prevent microbiological cross-contamination of different areas of the process plant. It is more usual to recover cleaning solutions in a recovery tank and restore the original concentration of the cleaning fluid, and then to re-use the recovered solution. Such systems will need to be monitored for the build-up of residual soils and the cleaning chemicals replenished as necessary.

In some situations, membrane filtration technology can be used to filter soil from cleaning solutions to enable a further extension of useful life.

Although not always recognised as such, CIP is a methodology to remove product residues from a process plant. It is not a means of eliminating micro-organisms from the system. This is the role of the post CIP sanitisation or sterilisation process using either chemical sanitisers or the application of heat to destroy micro-organisms.

Design for cleanability

The design of the process plant must conform to all documented hygienic design criteria. It is not usually possible to apply a CIP system to a process plant that was not designed for CIP in the first place.

Such hygienic design criteria have been extensively documented by the European Standard EN 1672-2 (2005), the European Hygienic Design and Engineering Group (EHEDG) and also by such bodies as the United States 3A authority.

The materials of construction of the entire process plant must be resistant to the food and cleaning chemicals to be applied, be non-toxic, smooth, non-porous and free from crevices.

Materials of construction

The most common construction materials are austenitic stainless steels such as AISI 304, 316 and 316L that display good resistance to corrosion in most environments except those containing high chloride content, especially under acidic conditions.

Products with high chloride contents require special metals such as titanium or alloys such as Hastelloy.

Often forgotten are the elastomers used for seals and gaskets that are necessary to seal various metal parts of a process plant, for example heat exchanger seals and pipe connections, and the effect that cleaning chemicals can have on them. The same applies to the use of plastics in hoses, sight glasses and pump rotors. Such elastomers and plastics must be resistant to the food product and the conditions in which the cleaning fluids are applied. It must also be demonstrated that there is no leaching of potentially toxic components from the elastomers and plastics materials.

Frequently used elastomers include:

- Nitrile rubber
- Nitril/butyl rubber (NBR)
- Ethylene propylene diene monomer (EPDM)
- Silicone rubber
- Fluoroelastomer (Viton)

Silicone and Viton are very effective at high temperatures whilst it must always be remembered that EPDM is not resistant to oils and fats. All plastics and elastomer materials must be routinely inspected as part of a preventative maintenance plan and replaced at the first signs of brittleness. Brittleness causes a reduction of elasticity and eventual failure of the ability to safely contain process fluids.

Surface finish

A smooth surface is generally considered to be easier to clean, while rougher surfaces require a

longer cleaning time due to deposit present in the pits. A surface roughness of no greater than 0.8Ra (the average departure of the surface profile from the calculated centreline) and expressed in μm is required by both the EHEDG and the US 3A authority.

Welds

Permanent welds are always preferred to dismantlable pipe couplings from a hygiene perspective. Dismantlable pipe couplings should only be used when it is necessary to access a particular part of the plant for maintenance.

Considerable attention is needed to the quality of the welds and it is usual to qualify plant welders for their ability to execute smooth and continuous welds. In many situations, a proportion of the welds will be inspected using X-ray techniques upon completion of plant construction.

Rough welds can harbour product soils and are difficult to clean.

Welds can be made automatically using orbital welders or manually but in both instances the internal surfaces must be purged with an inert gas such as tungsten (TIG – tungsten inert gas) to avoid contamination of the weld with air that might result in a porous weld.

A typical welding fault is to attempt to weld two pipelines together of different diameters. The diameter of the smaller pipe must always be expanded to match that of the larger pipe.

Dismantlable pipe couplings

There are a variety of proven hygienic dismantlable pipe couplings available, including:

- DIN 11851
- ISS (International Sanitary Standard) or IDF (International Dairy Federation)
- Clamp (to BS 4825-3)
- SMS (Swedish Metric Standard)

A final type, RJT, is not suitable for pasteurisation or sterilisation systems due to the formation of a crevice in the joint area, but is favoured on manual swing bends at flow plates due to a wide dimensional tolerance.

It is vital that all dismantlable pipe couplings are regularly inspected for leaks. It is equally vital that the joints are not over-tightened as this can cause irreversible compression and damage to the gaskets.

A common error is to combine metric and imperial fittings on process plant resulting in a step in the tube wall at the joint.

Other design features

Additional essential design considerations include the following aspects:

- Adequate draining (sloping pipework, eccentric reducers, correctly designed tank bottoms, and good pipework support). The process plant should drain to avoid microbiological growth and also to avoid potential corrosion. Residues of product and/or cleaning fluids can become further concentrated in a heated environment. This applies especially to chloride solutions where a level in excess of 50 mg/litre can become highly corrosive. In the event that a plant cannot be fully drained, it is preferable to leave it full of water after CIP, possibly with the addition of a preservative
- Correct installation of instrumentation with minimal dead space. Any transmitting fluid contained within the instruments must be approved for food contact
- Vessels with correct internal angles/corners and no dead areas. The welding seams of the vessels should not be in the corners but beyond the corner (Fig. 1). Corners should preferably have a radius in excess of 6 mm but as an absolute minimum, 3mm
- Angles and corners of process plant should be well radiussed to facilitate cleaning (Hasting, 2008)
- There should be good accessibility of all plant components for ease of maintenance

Examples of poor hygienic design

The following must be avoided in order not to compromise the hygienic integrity of the process plant:

- Dead legs in pipelines due to poor valve arrangements
- Dead legs due to the branch not being in the direction of flow as in the case of poorly installed temperature or instrument probes

- Pressure gauges not being on cut back tees
- The use of concentric reducers which prevent the line being drained or leave air pockets in the pipework.
- Pipework being looped over walkways
- Pumps being installed with the outlet wrongly positioned.
- Badly designed shaft seals and bearings. Wherever possible, bearings should be mounted outside of the product area to avoid contamination

Fouling of process plant

The processing of any food product results in fouling of the process plant by the build-up of soil debris on the surfaces - especially on those at which the product is heated. Deposits can also form from the water used to flush the plant.

When designing a CIP system, the following information is necessary:

- Type of soil
- Amount of soil
- Condition of soil

The main soil types are:

- Fats (animal, vegetable, mineral)
- Proteins (numerous build-up from amino acids)
- Carbohydrates (sugars such as glucose and fructose, and polysaccharides such as cellulose, starches and pectin)
- Mineral Salts (normally calcium salts)

For soil to be removed, it has to be soluble. Many of the above soils are not water-soluble and therefore require the use of other cleaning solutions.

Water soluble deposits include:

- Sugars and some salts

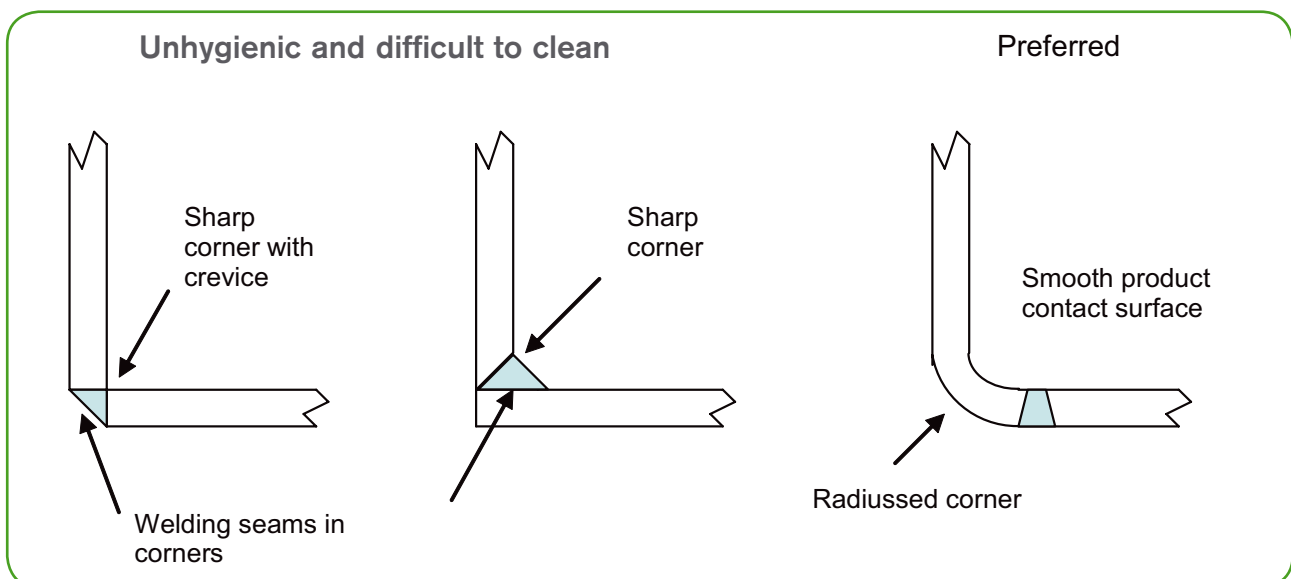

Fig. 1: Angles and corners of process plant should be well radiussed to facilitate cleaning (Hasting, 2008)

Alkali soluble deposits include:

- Fats
- Proteins

Acid soluble deposits include:

- Calcium salts
- Organic solvent soluble deposits
- Mineral Oils

Soils can be simple or highly complex mixtures depending on the food product that is being processed. The soil can be made more difficult to remove by the application of excessive heat treatment. This is why the temperature difference between the heating medium and the product should be kept to a minimum in the case of highly fouling materials such as UHT milk - ideally no more than 1° or 2°C.

Only practical experience can determine how long a plant can be run before it has to be cleaned, and how long the cleaning regime will need to be.

If plants are allowed to run for too long it may not be possible to clean without dismantling. This applies especially if the flow path becomes substantially blocked.

Any plant involving heat treatment must be carefully monitored to identify when cleaning is required. Fouling is directly related to the temperatures applied.

Dryness or ageing can influence the stability of the soil and its effective removal by cleaning chemicals.

The complexity of some soils can be illustrated by soils found in a dairy plant:

- Milk remaining in a pipeline
- Air-dried films of milk
- Heat-precipitated milk constituents (protein and milkstone)
- Fat
- Hard water salts
- Miscellaneous foreign matter

The situation becomes even more complex in a milk UHT plant as protein will be the predominant soil at temperatures of up to 115°C whilst mineral deposits will prevail as the temperature increases further.

Each type of soil will need a specific regime for removal.

Assessment of cleaning efficiency

After CIP, the product contact surfaces must be free from residual film or soil so that they do not contaminate food products subsequently coming in contact with them.

This can be measured using the following parameters:

- Contamination is not visible under good lighting conditions with the surface wet or dry

- The surface does not give a greasy feeling to clean fingers when they are rubbed on to the surface
- No objectionable odour is apparent
- A new white facial tissue wiped several times over the surface shows no discolouration
- The surface is completely wetted when water is draining from it
- No sign of fluorescence is detectable when the surface is inspected with a long wave ultraviolet light
- After sanitising the surface it will not cause re-infection of the product coming into contact with it

A commonly applied test is to determine the presence of micro-organisms in the final flush water, but in this respect, it is important to realise that micro-organisms will usually always be present in mains and bore hole water supplies. The total count of potable water should not exceed 100 cfu/ml (colony forming units) with the absence of coliforms and E.coli in 100ml.

It is therefore necessary to analyse the flush water for any increase in micro-organisms during passage through the plant.

A more recent technique is the use of ATP (adenosine tri-phosphate) sensors. ATP is a natural component and is the chemical in which energy is stored in all living cells such as bacteria. ATP is also present in food soils.

In the presence of luciferase (an enzyme derived from the firefly), the substrate luciferin, oxygen and magnesium ions, ATP is catalysed to ADP (adenosine di-phosphate) with the release of light. The quantity of light released is a direct measure of the concentration of ATP. There are several commercial suppliers of ATP sensing kits, which can detect very low levels of residual bacteria after CIP and sanitisation.

A very effective technique to determine residual soil within a complex plant component such as a valve or pump is to recirculate a solution of potassium permanganate through the component, whereupon it will react with any soil to form manganese dioxide. The permanganate is flushed out with water and replaced with a solution of hydrogen peroxide, and the inlet and outlet to the component sealed. The manganese dioxide within the soil acts as a catalyst for the decomposition of hydrogen peroxide to water and oxygen. The production of oxygen can be measured using a pressure gauge installed in the line.

The cleanliness of the surfaces of individual items of process equipment can also be assessed using swab tests where a pre-determined surface area is wiped with a sterilised swab and then incubated to detect micro-organisms.

Finally, the EHEDG has developed a very demanding CIP test to validate the hygienic design of individual plant components prior to release on to the market.

CIP design criteria

Not only is it essential that the equipment is properly cleaned, it is also fundamental that the product is protected from any possibility of contamination by CIP solutions.

Plant is cleaned by the combination of dissolving the soil or removing it by scouring of the surfaces. Before cleaning any product in the plant must be reclaimed.

After cleaning the plant must be sanitised (removal of any pathogenic organisms but not necessarily all micro-organisms).

A system of maintaining a physical break between a product line and a CIP line must be adopted at all times in order to eliminate the possibility of chemical contamination of the product.

Choice of chemicals

The choice of chemicals is governed by the materials of construction of the plant. As mentioned previously, the most common material of construction is austenitic stainless steels, which are very resistant to most cleaning solutions (with the exception of high-chloride solutions).

In the food industry, the most common form of fouling is the deposition of proteins. These are nearly always removed by hot alkali (caustic soda) assisted by wetting agents that break up the protein into water soluble units. Typically 2% caustic soda will be used at temperatures of up to 85°C. For highly fouled surfaces of up to 4% can be applied.

Milkstone and calcium deposits are easily removed by the use of a dilute mineral acid. Nitric acid is the most common although phosphoric acid can also be used. Typically 0.5% nitric acid at temperatures up to 50°C is used. Above this temperature, heat exchanger gaskets can be adversely affected. Hydrochloric or sulphuric acids should never be used.

Apart from basic caustic soda and nitric acid, special formulations have been developed by detergent manufacturers containing added components such as sequestrants. A typical sequestering application is the solubilisation of calcium and magnesium salts using EDTA (ethylenediaminetetra-acetic acid) to prevent precipitation by alkaline detergents.

Acid should never be used ahead of the alkaline clean when removing milk deposits. Acid will cause the precipitation of protein with the result that it is more difficult to subsequently remove.

Sanitation is achieved by the use of hot water, hypochlorite or one of the peroxide based sterilants such as Oxonia P4.

If hypochlorite (sodium) is used for sanitising the strength should not exceed 150ppm free chlorine, the temperature be kept below 40°C, and the circulation time kept below twenty minutes. Typically 100 ppm at 25°C for two minutes is adequate for pre-cleaned surfaces.

Great care is needed should there be any aluminium, copper or bronze product contact surfaces in the line. This should not be the case, however, in a modern process plant. Such materials are commonplace in older brewery process units. Caustic soda is corrosive to aluminium whilst acids will attack copper and bronze.

Circulation time

The period of circulation depends on the degree of fouling and the type of equipment being cleaned. Typically 20 mins of caustic circulation is required for pipework and vessels.

Pasteurisers and UHT plants which suffer from higher levels of fouling may require up to 40 mins of caustic circulation.

Acid circulation is normally 10 mins.

Operating temperatures

Contrary to popular belief, the higher the temperature the poorer the soil removal with an optimum at 50°C. In practice, caustic is usually circulated at higher temperatures in order to improve the sanitising effect.

Flow velocity

Process plant should always be cleaned under turbulent flow conditions. The efficiency of cleaning under laminar flow conditions, i.e. <1.4 m/s, is not sufficient. For this reason, flow velocities in the region of 1.5 to 2.1 m/s are usually applied.

The use of a high velocity also improves cleaning efficiency in small dead legs, for example at instrumentation or sample valves.

It has been generally considered that flow velocities in excess of 2.1 m/s are not beneficial, but recent work indicates that the application of even higher flow velocities can enable a beneficial reduction in cleaning chemicals.

Selection of spray devices

Scouring and wetting of the surfaces inside tanks and vessels is achieved by the use of spray devices. Simple spray balls are the most commonly used. The holes are positioned to provide maximum impingement in areas of high fouling. These devices run at relatively low pressures (1 to 2 bar).



Fig. 2: CIP MINI system

Rotating jet devices must be used for vessels with a high degree of fouling or with large diameters (>3m). These operate at higher pressures (5 bar).

Vessels with top mounted agitators must always be fitted with two spray balls to overcome shadows cast by the agitator shaft and blades. A similar consideration often exists for tank vents where a small spray ball may need to be positioned at the vent to improve CIP.

Calculation of flow rates for spray balls

The size of the spray device and its capacity are dependent on the diameter of the vessel. Spray balls are only suitable for vessels up to 3m in diameter.

- For vertical vessels (incl. silos):
Flow rate (l/h) = diam (m) x 3.14 x 1490
- For horizontal tanks:
Flow rate (l/h) = diam (m) + length (m) x 2 x 1490
- For other tanks:
Flow rate (l/h) = side (m) + end (m) x 2 x 1490

When the rate is known the correct size of spray ball can be selected. Orifice pieces will be used to set the rates.

A range of spray devices is available from specialist manufacturers.

Selection of CIP pumps

CIP supply pumps should always be of the centrifugal type to give the necessary variations in flow and pressure. Each CIP supply pump should be individually sized to handle the highest rate and highest pressure circuit it will supply.

Orifice pieces should be used where reduced rates are required (for example before spray balls as mentioned previously).

CIP return pumps should always be of the self priming liquid ring type due to the scavenging duty required. CIP return pumps should be sized to return fluids at a rate 10% greater than the supply pump.

CIP booster pumps should also be of the centrifugal type and should be carefully sized so as not to introduce cavitation into the circuit.

Chemical dosing pumps for adding concentrates to bulk tanks should be sized to transfer at as high a rate as is feasible depending on the concentrate storage method. Normally carboys are used which limit the rate to 250 l/h.

Chemical dosing pumps for adding concentrates in-line should be sized to give an even addition to the flow. A flow rate of 60 l/h is typically used.

Purging of product from the process plant

Recovery of product from process lines is increasingly important in today's economic environment. In a typical 1 million litres day drinking milk plant a 0.5% loss of milk is equivalent to a loss of raw material valued at £1,300 per day or £475,000 per year. It is thus appropriate to pay special attention to product recovery.

Purging can be achieved using water, air or an inert gas and can either be part of a process sequence or the first stage of a CIP sequence. Accuracy is important to ensure product is not left in the line nor that purge medium is added to the product.

Water purging is the most accurate medium and time is commonly used to control the process. But this can be inaccurate unless combined with positive pumps.

Where possible flow meters should be used combined to known pipe volumes and conductivity probes provide an accurate detection of the interface between product and water.

Purging of heat exchangers can result in large interfaces especially in multi-pass machines.

Diluted product can be recovered for addition back to the raw feed (except in the case of drinking milk where legislation prohibits any dilution with water) or used for animal feeding. In the case of drinking milk, SPX has developed reverse osmosis membrane technology to concentrate the milk solids back to the original level. The recovered milk can then be blended with fresh milk for production of products such as cheese or yoghurt.

A 1 million/day drinking milk plant can generate 25 to 35,000 litres of white water per day equivalent to some 10,000 litres normal milk. The value of this white water over a year can be as high as £900,000 per annum, easily justifying the installation of a reverse osmosis recovery system.

With other dairy products, it is often possible to blend a small proportion of recovered diluted product with the next batch of raw feed.

Re-use of cleaning solutions

It is common practice and economically prudent to re-use both caustic soda and acid solutions. Where high degrees of fouling are encountered (for example in milk pasteurisers), it is not always practical to recover the solutions.

To minimise water usage, final rinse water is usually recovered and used as the first rinse of the next clean. After a certain number of cleans (approx. 100) it is advisable to dispose of the solutions due to a build-up of solids in the chemical solutions.

Alternatively, SPX has also developed membrane systems to actively filter the soil from cleaning solutions to enable effective re-use.

If it is mandatory that no contamination occurs between batches, single use systems must be used.

It is not practical to re-use sanitising solutions such as hypochlorite or oxonia due to a short active life.

CIP cycles

Every CIP circuit will have its own unique sequence of operations and cycle times. The different types of clean in an automated operation will usually include the following operations:

- Caustic wash
- Full clean (with acid)

- Hot rinse
- Cold clean
- Intermediate clean
- Pulse cleans (not recommended)
- Snake cleans

Useful guidelines for the design of the CIP operation are:

- Do not mix line cleans with tank cleans.
- Size the cleaning rate for the largest pipe diameter in the circuit.
- Do not mix large diameter with small diameter line cleans.
- Always ensure that every component in the line receives a turbulent flow rate even if this means other components see a higher rate. For example a plate heat exchanger in a pipeline circuit may require a flow rate higher than 2.1 m/s in the line.
- Avoid very long line cleans.
- Where possible clean tanks individually and not in pairs.
- Do not try to clean equipment that is not designed for CIP (for example cheese vats and tanks with lift off lids).

A CIP cycle is generally made up of a combination of the following steps:

- Initial purge to recover product, either into product tanks or to a product recovery system.
- First rinse using recovered water (from final flush of previous CIP cycle) to remove gross soil.
- Caustic wash with or without recovery to remove residual adhering debris.
- Intermediate rinse to clear caustic from the system.
- Acid wash with or without recovery to remove mineral scale.
- Final rinse to clear any remaining chemicals from the system.
- Sanitation using heat or chemical sanitiser to destroy any residual organisms.

Additional special operations that may be included are:

- Warm pre-rinse prior to initial rinse to remove fats from pipe walls
- A two stage caustic wash in the case of heavily fouled equipment - the first wash is routed to drain whilst the second wash is recovered and re-used.
- Intermediate cleans while maintaining sterility in the case of a UHT plant where the production run length is compromised by fouling to an extent that a high delta T is required at the heat transfer surfaces to maintain production temperatures. A high delta T can lead to a runaway situation where deposit forms at an exponential rate.

At the end of each CIP cycle the unit should automatically dose fresh cleaning chemical into the bulk tanks to make up for that lost during the clean.

Each day a service cycle should be run to check the concentrations, then dose to achieve the correct strength, and to warm up the bulk tanks.

Service cycles should also be available for dumping the caustic/acid tank and making up fresh solutions.

An example of typical dairy pipework clean is as follows:

Normal daily clean:

- Product recovery using fresh purge water
- Initial rinse (3 to 5 mins) using recovered water to drain
- Caustic wash at 75°C (10 to 20 mins) with recovery
- Final rinse (3 to 5 mins), fresh water to recovery tank
- Cold sanitation (3 to 5 mins)
- Flush with fresh water and drain plant if hypochlorite is used
- Leave full if Oxonia is used and drain the following day

Once a week the following extra operations will be added, primarily to remove mineral deposits originating from rinsing water:

- Intermediate rinse (2 to 5 mins), following caustic wash fresh water to recovery tank
- Acid wash at 50°C (10 to 15 mins) with recovery

Design of CIP bulk units

The bulk unit is the heart of a CIP system.

A bulk unit consists of a combination of the following:

- Bulk tanks for:
 - Fresh water
 - Recovered water
 - Dilute caustic
 - Dilute acid (optional)
 - Hot water (optional)

The size of the tank should be calculated by calculating the capacity of the worst case circuit on each of the CIP supply pumps, adding them together and doubling the result

- Product recovery tank (optional)
- CIP supply pump(s)
- As a general rule there should not be more than 6 circuits per CIP supply pump to avoid overloading and/or congestion amongst the routes
- Filters on each supply line to prevent blockage of the spray balls
- CIP solution heater(s), either in-line on each circuit or as re-circulation heaters on the bulk tanks. In-line heaters are used if hot water sterilisation employed. Recirculation heaters are used if there are a large number of circuits
- In some cases heat exchangers with regeneration are used to eliminate the need for insulated bulk tanks and to provide a gentle heating profile

- Restrictor valves on the pump outlets are used to reduce the flow when following a hot cycle with a cold cycle on tank cleans to prevent implosion
- Double seat ball valves on bulk tanks are used to reduce risk of accidental leakage into water stream
- Dosing pumps for concentrated caustic and acid. Dosing pumps for sterilant with injection points on each supply line
- Recirculation loops for sterilant circulation or break tanks

The following instrumentation is required as a minimum:

- Temperature loops for control of the caustic and acid temperatures
- Conductivity transmitters for monitoring of the caustic and acid strengths
- Temperature probes in the return lines for detecting when the return temperature has reached the desired set point and the timers can be started
- Conductivity probes in the return lines to detect the interface between rinse water and caustic or acid solutions. Also used to ensure that sterilants have been added to the final rinse water
- Conductivity probe to detect white water when product recovery is incorporated

The question that must then be asked is whether there will be a central or distributed CIP system. In a central system the complete process facility is supplied by a single centralised system. In a distributed system, individual sections of the plant can be cleaned with a local dedicated unit.

A dedicated CIP unit will be mandatory for some process operations such as membrane processing systems that cannot tolerate the use of aggressive caustic or nitric acid cleaning solutions and require specially formulated chemicals so as not to irreversibly damage the membranes.

As mentioned previously, there should be no more than 6 supply pumps from each unit and separate units should be considered for pasteurised and raw milk areas.

With fermented dairy products, the fermentation CIP should always be separate from the fresh milk section to avoid possible contamination of the milk with bacteriophage, which will reduce or even prevent the fermentation process of the next product batch.

UHT plant should also always be cleaned separately from upstream sections of the process.

CIP of the CIP unit

Frequently overlooked with multi-use CIP systems is the need to CIP the system itself to remove soil that has built up during cleaning of the process plant. The chemical storage tanks should be partially drained to

remove the soil and any product and water storage and recovery tanks fully drained. CIP fluids should then be recirculated through spray balls in each vessel.

At the end of this sequence, the chemical storage tanks are replenished and the water/product storage and recovery tanks rinsed with water before re-use.

Standard APV CIP units

Apart from the installation of large bulk units and/or ed CIP units during initial plant design, SPX also manufactures a range of standard skid-mounted CIP modules for cleaning of individual process units. These systems are ideal for upgrading of CIP systems to reduce bottlenecks and enable the plant to go back on commercial production.

Three standard ranges are available:

- APV MINI - basic single use skid-mounted system with optional water rinse and product recovery tanks
- APV MIDI - multiple use skid-mounted system
- APV MAXI - multiple use system with multiple circuits and tanks custom built on application

APV MINI CIP system

The CIP MINI is a single-use system with a choice of tank sizes and is designed for efficient cleaning of pipeline systems, tanks and processing plants.

Basic specification

- Sanitary, single use CIP w/o recovery, single tank
- Four standard volumetric sizes, (400, 600, 850 and 1,250 litres)
- Four standard circulation rates, (8,000, 12,500, 20,000 and 36,000 lph)
- Frame mounted tank, equipment and panel (Stainless Steel)
- CIP Solution heating by APV ParaTube, Stainless Steel shell and tube, 12°C per pass
- Stainless Steel steam control (Samson) w/float trap (Sarco FT series)
- Single chemical delivery system (pump, injector and valves)
- Pneumatic, single-seat rising stem sanitary valves std.
- Control tops w/dual feedbacks and solenoids on APV valves and pilot air sv's on service valves
- CIP supply temperature transmitter
- CIP return temperature transmitter
- EHEDG APV process equipment (valves, pumps and fittings)
- EHEDG sanitary Endress & Hauser Instrumentation

(temperature and level)

- Std. IP65 Stainless Steel, high and low voltage panel
- Integral, IP65 panel mounted - Siemens Simatic S7-315-2 PN/DP Siemens MP277 10" HMI panel , mounted in the door of the control panel
- Std. three-step CIP (prerinse, alkali circulation and postrinse)
- IEC Electrical Std. (230/460V, 3-Phase, 50 Hertz)

APV MIDI CIP system

The CIP MIDI is intended for small to medium CIP applications, and will cater for the following capacities and sizes, up to a maximum of two CIP circuits per CIP set.

Basic Specification

- Sanitary, reclaim CIP, multi-compartment horizontal tank (alkali, acid)
 - Rinse water by direct supply
 - One circuit or two circuits
 - Five standard volumetric sizes, (1,000, 1,500, 2,000, 3,000 and 4,000 litres)
 - Three standard circulation rates, (8,000, 12,500, 20,000 lph)
 - Frame mounted equipment and panel (Stainless Steel)
 - Free-standing horizontal multi-compartment tank
 - CIP Solution heating in-tank by APV ParaTube, Stainless Steel shell and tube, 12°C per pass
 - Stainless steel steam control (Samson) w/float trap (Sarco FT series)
 - Pneumatic, single-seat rising stem sanitary valves std.
 - Control tops w/dual feedbacks and solenoids on APV valves and pilot air sv's on service valves
 - EHEDG APV process equipment (valves, pumps and fittings)
 - EHEDG sanitary Endress & Hauser Instrumentation (temperature and level)
 - CIP supply flow transmitter (magnetic)
 - AC variable speed drive (Danfoss or Allen-Bradley Powerflex) on CIP supply pump
 - CIP return conductivity transmitter
 - CIP return flow switch
 - Std. IP65 Stainless Steel, high and low voltage panel
 - Integral, IP65 panel mounted - Siemens Simatic S7-315-2 PN/DP Siemens MP277 10" HMI panel, mounted in the door of the control panel
 - Std. three-step CIP (prerinse, alkali circulation, postrinse, acid circulation, postrinse)
 - IEC electrical std. (230/460V, 3-Phase, 50 Hertz)
-

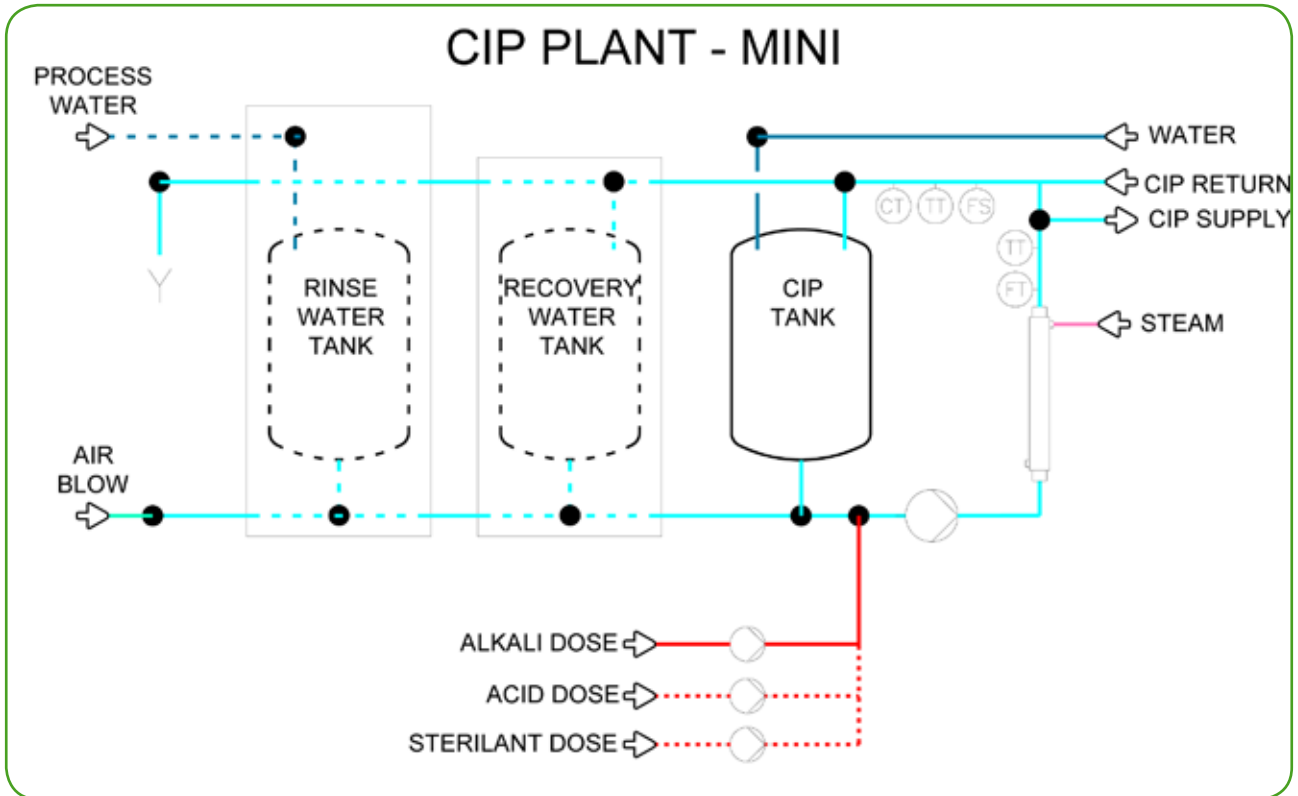

Fig. 3: APV CIP MINI system

Equipment sizing (production capacities)

| CIP MINI SIZING INFORMATION | | | | | | |
|-----------------------------|-----------|----------|-----------|--------------|-------------|--------------------|
| MODEL | FLOW RATE | | TANK SIZE | | TANK DROP | DISCHARGE & RETURN |
| | LPH | GPM (US) | LITRES | GALLONS (US) | O.D. INCHES | O.D. INCHES |
| MINI 1.5 | 8,000 | 35 | 400 | 106 | 2 | 1.5 |
| MINI 2 | 12,500 | 55 | 600 | 158 | 2.5 | 2 |
| MINI 2.5 | 20,000 | 88 | 850 | 224 | 3 | 2.5 |
| MINI 3 | 36,000 | 158 | 1,250 | 330 | 4 | 3 |

Production capacities

| CIP MINI WASHING DUTY SECTION | | | | |
|-------------------------------|----------------------|----------------------|------------------|------------------------|
| MODEL | PIPELINE WASH (2M/S) | | TANK WASH ** | |
| | MAX. PIPE DIA. (IN) | MAX. PIPE LENGTH (M) | TANK SIZE (L) | TANK SIZE (GALLONS US) |
| MINI 1.5 | 1.5 | 200 | 2,000 - 10,000 | 500 - 2,500 |
| MINI 2 | 2 | 150 | 5,000 - 25,000 | 1,300 - 6,500 |
| MINI 2.5 | 2.5 | 150 | 10,000 - 50,000 | 2,500 - 12,500 |
| MINI 3 | 3 | 150 | 20,000 - 100,000 | 5,000 - 25,000 |

** INDICATIVE ONLY - sizing should be based on specific tank spray device requirement

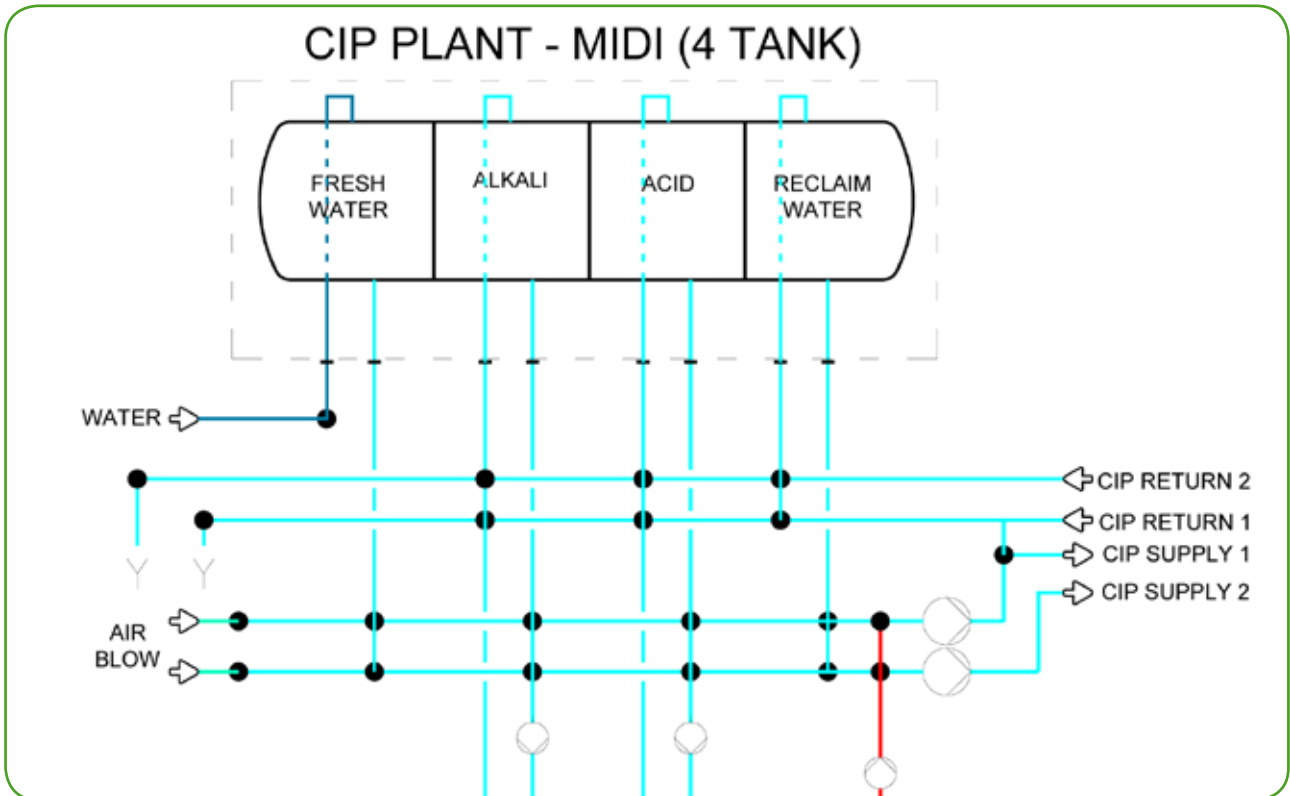

Fig. 4: APV CIP MIDI system

Equipment sizing (production capacities)

| CIP MIDI SIZING INFORMATION TANK SIZE | | | | | | | |
|---|-------------|-----------------|--------------|------------------|--------------|-----------------|-----------------------|
| FLOW RATE | | ONE CIP CIRCUIT | | TWO CIP CIRCUITS | | PUMP SUCTION | DISCHARGE & RETURN |
| LPH | GPM (US) | LITRES | GALLONS (US) | LITRES | GALLONS (US) | O.D. INCHES | O.D. INCHES |
| 8,000 | 35 | 1,000 | 260 | 2,000 | 520 | 2 | 1.5 |
| 12,500 | 55 | 1,500 | 390 | 3,000 | 780 | 2.5 | 2 |
| 20,000 | 88 | 2,000 | 520 | 4,000 | 1,040 | 3 | 2.5 |

Automation of CIP systems

All CIP systems should be automated to some degree. The level will depend on the sophistication of the complete plant.

The lowest level of control which, however, is not recommended is:

- PLC controller on the bulk unit only operating the unit valves, conductivity switches to monitor chemical, temperature control and the timing sequences.
- No interface with the process plant.

As a minimum, a semi-automatic level of control should be applied that includes feedback from the process plant to indicate that the correct routes have been made.:

Fully automated systems offer the following benefits:

- Full integration between the CIP system and process plant
- Computer controls all the bulk unit operations including valves, conductivity probes, no-flow and temperature switches, temperature control and the timing sequences
- Computer operates all valves, pumps and agitators on the process plant and monitors level probes and other instrumentation
- Built-in inhibition of CIP of operating routes or tanks containing product
- Tanks and routes flagged to prevent product operation before fully clean

The automation system should record all process parameters involved during CIP including:

- Cleaning chemical strength and temperature
- Cleaning times

CIP analysis and optimisation

The efficiency of a cleaning cycle is of the utmost importance, but the cost should be kept as low as possible in terms of cleaning chemicals and production downtime. SPX has developed a comprehensive CIP analysis and optimisation tool called "CIP Expert" to help food processors minimise costs and maximise productivity.

The key benefits of CIP Expert are:

- Reduction in cleaning and sanitising chemicals, water, steam and electricity
- Increased production time
- Reporting and trending of each CIP cycle (each CIP cycle is given a unique cleaning number and can be compared to a validated CIP sequence)
- Archiving of cleaning data and sensor readings
- Chemical usage
- Cleaning line occupation to assist with production planning



Figs. 5 and 6: CIP MINI control cabinet



- Displays uncleaned equipment with last cleaning date and time
- Automated check that correct CIP procedures are being applied
- Automated check on sensor readouts
- Backup alarms and reporting of CIP irregularities

Pipework and valve designs

The routing of CIP solutions can range in complexity from simple manual manipulation of pipes and bends to the use of sophisticated double seat valves (as described later). The commercial benefits of the use of double seat valves to eliminate the need for lengthy manual connection of CIP circuits are being increasingly realised. Cleaning times can be substantially reduced, enabling the plant to resume production in the shortest period of time.

The use of double seat valves also enables parts of the plant to be safely cleaned whilst other parts of the plant remain in production, for example cleaning a product silo whilst another silo is still sending product for processing. This involves the use of relatively complex valve manifolds.

In all cases the protection of the product from CIP fluids is paramount.

The systems available are:

- "Key Piece" systems
- Selector panels with swing bends
- Selector panels with checked swing bends
- Single seat valve arrangements (double, single or no feed back)
- Double seat valve arrangements (with or without pulsing units).



Fig. 7: Typical APV DELTA valve manifolds

These systems all provide for a physical break in the pipework between product and CIP thus ensuring that no contamination can take place.

An alternative system based upon pressure balance to reduce CIP contamination of product is NOT recommended.

This system relies on maintaining a lower pressure in the CIP line than the product line, ie in the case of a fault, product leaks into CIP and not vice-versa. An example of common use by others is on tank outlets where the CIP return pump creates a negative pressure in the CIP line. However, if this return pump should fail then pressure will increase in the line with potential leakage of CIP into product.

APV double seat valves

SPX manufactures a comprehensive range of double seat valves to ensure safe separation of product from CIP fluids. The main principle of the valves is to have two independently operating valve seats, one of which will route product and the other to route CIP fluid.

In between each valve seat is a leakage chamber that routes directly to atmosphere. Thus in the event of either valve leaking product or CIP fluid will seek the path of lowest resistance to drain. Leakage can be visually detected and corrected.

The main benefits of the APV Delta 3+ valve are detailed below. Special 3A approved double seat valves are available for the North American market.

Water hammer

A common fault in a CIP system is water hammer which can be engineered out by careful design. Transient shocks up to 20 bar are possible through water hammer with the result that instruments, pipe supports, diaphragms and the pipework itself can all be damaged.

To reduce the possibility of water hammer, the following considerations should be made:

- Always stop pumps before closing valves.
- When changing routes, always make sure that the supply valve to the new route is opened before the other route is shut.
- Close plug valves in the direction of flow.
- Use dampeners on butterfly valves.
- Use ball valves instead of butterfly valves where possible.
- Use pulsation dampeners where necessary.
- Try not to drain lines.

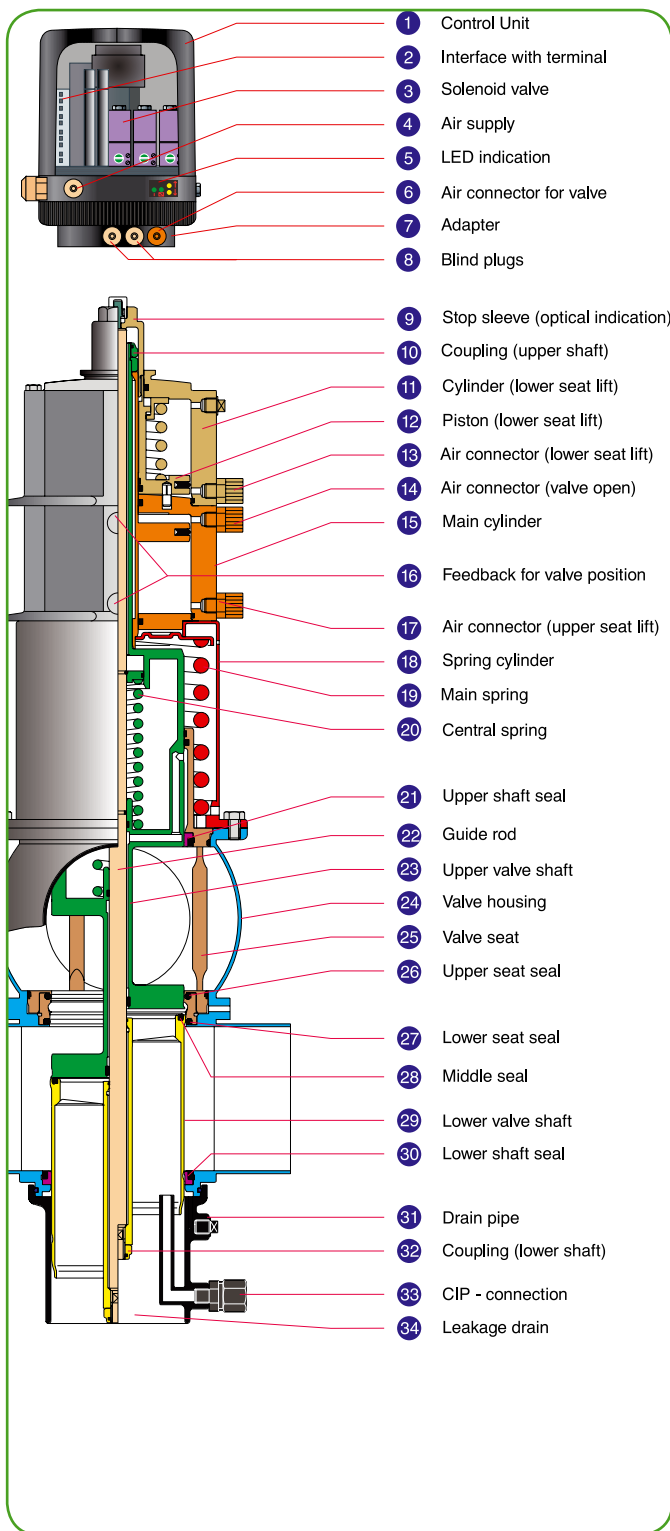

| FEATURES | BENEFITS |
|--|---|
| Functional reliability and customer's product integrity | |
| Two independent seat sealing arrangements and leakage cavity with discharge to atmosphere. | Mix-proof operation and safe separation of two different media. Reliable production – no risk of mixed fluids. Possible to see when seals are leaking – reducing product loss. |
| Balanced upper and lower valve shafts. | Water hammer safe in open and closed position, removing risk of media mixing. Smooth opening and closing of valve regardless of flow direction. |
| Large separation cavity drainage port. | No pressure is built up avoiding mixed media. |
| EHEDG certificate. | Meets industry standards. |
| All moving parts are contained within valve envelope during operation. | Reduced risk of external contamination during wash-down or other sources. |
| Cleanability | |
| Innovative, unique comprehensive cleaning process of ALL wetted surfaces. | Ensures upper and lower seat seals, shaft seals and shaft surfaces are cleaned eliminating bacteriological growth possibilities. More comprehensive cleaning than any competitor and above EHEDG test requirements. A unique selling point! |
| As standard internal surfaces electro-polished to <math><0.8 \mu\text{m}</math>. | Improves cleanability during CIP cycle. |
| Separation cavity spray cleaning mechanism provided for optional use. | Separation cavity spray cleaning mechanism provided for optional use. |
| Installation, commissioning and maintenance | |
| No compressed air required for service. | Easy, safe and low cost maintenance. |
| Metallic stop controls the seat lifting stroke length. | Easier, faster commissioning and maintenance. Reduces CIP consumption. |
| Identification numbers marked on profiled seals. | Ease of seal identification for ordering and maintenance purposes. |
| Low weight/compact design compared with typical competitor valves. | Less space required for installation. Easy, safe and reduced cost installation and maintenance. |
| Adjacent upper and lower shaft coupling. | Easy, one-person removal and replacement of shafts during maintenance. |
| Fixed stem position proximity switches. | No adjustment required during installation and maintenance. |
| Mix and match upper and lower body sizes. | Flexibility of design and installation. |

Fig. 8: APV DELTA DA3+ mixproof valve

| FEATURES | BENEFITS |
|---|---|
| Life cycle costs | |
| Seat lifting as a standard - note some competitors only offer this as an option. | Reduced cost of acquisition. |
| Radial seat seals. | Dramatically reduces product loss during operation of valve - compared with losses generated by use of axial seat seals. Cleaner operating environment due to eliminating evaporation of product losses caused by use of axial seat seals. |
| Metal orifices control CIP flow during seat lift. | Optimised CIP process with minimized CIP fluid consumption. A unique selling point! |
| Seal sizes are grouped over several valve sizes, for example same kit for: DN40, DN50, DN65 and 1.5", 2", 2.5", 3". | Reduced inventory and maintenance costs. |
| Optionally available with APV Control Unit technology including Direct Wired or Fieldbus control alternatives. | Reduce compressed air lines and connections. Eliminate external solenoid valve cabinets. Reduce electrical control wiring. Reduces valve response time. |

Innovative new CIP technology

The latest development in CIP technology is the use of electro-chemically activated water (ECA) to produce both cleaning and sanitisation solutions at considerably lower cost than normal chemicals.

ECA water is produced through the electrolysis of a solution of sodium chloride. In the absence of a permeable membrane, a mixture of anolyte and catholyte will be produced. This is essentially a mixture of sodium hydroxide and hypochlorous acid.

When a permeable membrane is positioned between the electrodes, it is possible to separate the two electrolytes. A variation of the flow rate past the respective electrodes enables different concentrations of the two electrolytes to be obtained.

In practice, the pH of the anolyte will be adjusted to pH 7.0 - 7.5 in order to maximise the concentration of active hypochlorous acid and prevent it converting to free chlorine or hypochlorite. This adjustment may be through addition of small amounts of catholyte or sodium bicarbonate.

The electrolytes need to be stored in plastics containers until diluted for use.

Hypochlorous acid is some 50 times more effective a sanitiser than hypochlorite. It is the chemical that the body naturally produces in response to an infection. When an infection is detected, the body sends neutrophil blood cells to encircle the bacteria or virus and produce a number of cytokine, including hypochlorous acid.

A concentration of just 0.1 ppm hypochlorous acid is sufficient to secure a log 3 reduction of E.coli within 10 secs.

ECA water has several important benefits to food processors:

- Can replace chemical detergents and sanitizers
- Improved microbial efficiency
- Destroys all forms of pathogens
- Reduction in CIP time
- Reduced water usage
- Improved effluent management
- Non Toxic, a true "clean" technology
- On-site, on demand generators
- Harmless to man and the environment

Most application work has been conducted in the carbonated soft drinks industry where it is used as a replacement to conventional sodium hydroxide and nitric acid cleaning solutions, typically with paybacks of less than 4 months.

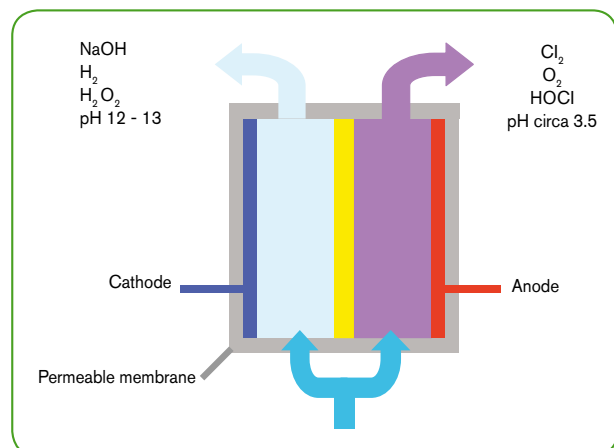

Fig. 9: Basic electrolysis cell with a permeable membrane separating the cathode from the anode

Glossary

The following definitions of terms are commonly used in the design of CIP systems:

B

Bactericide

An agent that destroys bacteria.

Bacteriostatic

A state of inhibiting the growth of bacteria.

Beerstone

A mixture of proteinaceous debris, water hardness and calcium oxalate mineral salts.

Biocide

An agent that kills living material .

Biodegradable

A substance possessing the means of being broken down by biological action. In effect, complex molecules are broken down by bacterial action to simpler substances.

Buffering

Stabilising the pH value of a solution under cleaning conditions.

C

Carbohydrates

A large group of organic compounds composed of carbon, hydrogen and oxygen only. Usually the hydrogen and oxygen atoms are in a ratio of 2:1 as in water. This group includes sugars, gums, starches and cellulose.

Chelation

Similar to sequestration, except that the chelating agent forms a typical ring structure with water hardness constituents.

Cleaning

The cleaning process, as distinct from sterilisation. The term 'cleansing' is construed as applying to a combination of cleaning and sterilisation.

Corrosion inhibitors

See Inhibitors.

D

Deflocculation - or dispersion

is the action of breaking-up soil aggregates into individual particles.

Descalant

A scale removing agent, usually an acid used to remove water hardness salt.

Detergents

Substances capable of assisting the cleaning when added to water. They include soaps, organic surface active agents, alkaline materials and acids in certain instances.

Disinfection

The destruction of all pathogens. Often used within the context of C.I.P. as being synonymous with sanitation.

Dissolving

A chemical reaction which produces water-soluble product from water-insoluble soil.

Diversion

The act of bringing into and keeping in suspension undissolved soiling matter.

E

Emulsification

A mechanical action of breaking-up fat and oil into very small particles which are uniformly mixed with the water used.

Eutrophication

A process of enrichment of water by plant nutrients as a result of which there is increased productivity of algae and aquatic vegetation.

F

Fats

Natural organic compounds which occur in plants and animals and serve as storage materials. The distinction between fats and oils is largely one of melting point.

H

Hygroscopic

Having a tendency to absorb moisture.

I

Inhibitors

Substances capable in specific instances of minimising the corrosion of certain metals.

M

Micron

One thousandth of a millimetre. Usually written 'µm'.

Milkstone

A deposit. which contains calcium caseinate and calcium phosphate with associated proteinaceous debris.

Mineral salts

Mixtures and compounds of inorganic composition such as calcium, magnesium, iron, or phosphorus not belonging to the class of carbon compounds associated with organic chemistry.

P

Pathogens

Disease-producing organisms.

Penetration

This is the action of a liquid entering into porous materials through cracks, pinholes or small channels. Often this action can be considered as a part of wetting.

Peptizing

This involves degradation in molecular size and is the physical formation of solutions from soils which may be only partially soluble.

pH value

A measurement of the hydrogen ion to determine the acidity or alkalinity of the solution. It is defined as a base 10 logarithm of the reciprocal of the hydrogen ion concentration. A neutral solution has a pH of 7 and an acid solution has a pH of less than 7. An alkaline solution has a pH greater than 7. The range extends from 0-14 and applies only to dilute solutions.

Protein

High molecular weight organic compounds containing carbon, hydrogen, oxygen, nitrogen, built up from amino-acids. Essential in food to build body tissues.

R

Rinsing

Rinsing is aided by reducing the surface tension of the water used. This enables the solution of suspension to be flushed easily from a surface.

S

Sanitisation

This defines the state of physical cleanliness, which requires the removal or destruction of micro-organisms that can cause destruction or infection of the object being sanitised. There can thus be sanitisation without sterilisation. This process reduces the number of bacteria in plant and utensils to a level consistent with acceptable quality control and hygienic standards.

Saponification

Saponification is the chemical reaction between an alkali and an animal or vegetable fat resulting in a soap.

Sequestering agent (sequestration)

A class of chemicals which combine with calcium and magnesium salts such as those occurring in hard water to form water-soluble compounds, generally enhancing the detergent operation.

Softening

Water softening is the removal or inactivation of the hardness of water. This can be achieved in a variety of ways such as precipitation or sequestration.

Soil

The milk or beer residues, scale and other deposits which have to be removed from plant and containers during the cleaning process.

Sterilisation

Sterilisation is explicitly defined as the complete and total destruction of all living organisms. Note that this can still mean the equipment can be physically dirty, although by definition sterile.

Stoichiometry

Relationships in chemistry dealing with determinations of combining proportions or chemical equivalences
Substrate - the foundation for soil deposition, i.e. the vessel or pipeline inner surface.

Surface active agent (surfactants)

Substances capable of modifying the physical forces existing at surfaces, such as between liquids and solids permitting more intimate contacts and facilitating mixing.

Suspension

Is the action which holds up insoluble particles in a solution.

Synergism

A combined or coordinated action, between two or more components, which produces a greater total effect than the effected sum of all the individual actions considered in isolation.

W

'Wetters'

A jargon term used for agents that lower the surface tension of a solution and improve wetting, i.e. surfactants.

Wetting

Wetting is the action of water in contacting all surfaces of soil or equipment.

References:

Hasting, APM (2008) Cleaning-In-Place: Dairy, Food and Beverage Operations, 3rd Edition, Society of Dairy Technology, Huntingdon, UK



SPX Flow Technology
Pasteursvej, DK-8600 Silkeborg, Denmark
Phone: +45 70 278 278 Fax: +44 70 278 330

SPX Corporation reserves the right to incorporate our latest design and material changes without notice or obligation.

Design features, materials of construction and dimensional data, as described in this bulletin, are provided for your information only and should not be relied upon unless confirmed in writing.

Issued: 03/2010 22003-02-03-2010-GB

Copyright © 2010 SPX Corporation